

Performance Converter Mounting Ring Kit

Part No.
GM-RK-15

- Impeller Hub
- Inner Stator Race
- 35-Tooth Turbine Hub
- Thrust Washer
- Pilot
- Mounting Ring
- Flathead Bolts (3)

Patent No. 7,565,958

GM 4L80-E, Single-Plate

Unit Size: 10" • Core: GM 245mm • Dampened: Yes • Turbine Hub Input Spline Count: 35

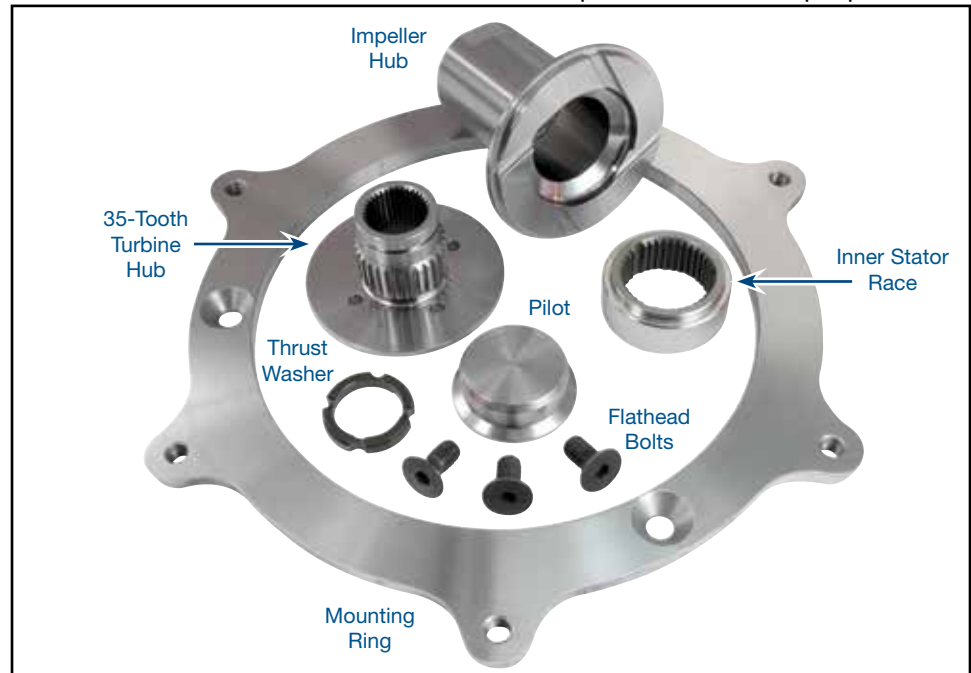

1. Impeller Assembly (Figure 1)

- Remove the stock GM 245mm impeller hub by boring a 3.380–3.385" diameter hole on center in the stock GM 245mm impeller.
- Install the Sonnax impeller hub from the outside. Weld around the O.D. of the impeller hub, making sure that it is centered on the impeller.

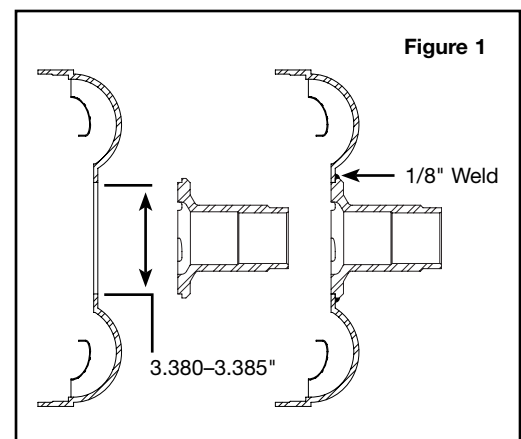

2. Turbine Assembly (Figure 2)

- a. Bore a 3.200–3.205" diameter hole on center in the stock GM 245mm turbine. This will remove the OE turbine hub.

NOTE: The mounting diameter is different than non-lockup performance converter kit turbine hubs. Also different from other performance converter kits is that both flanges of the OE turbine hub assembly must be removed.

- b. Install the Sonnax turbine hub into the turbine from the front cover side. Weld around the O.D. of the turbine hub.

3. Front Cover Assembly (Figure 3)

- a. Remove the pilot of the stock GM 245mm front cover. From the outside of the cover, bore a 1.750–1.752" diameter hole.
- b. Install the Sonnax pilot from the outside of the cover. Weld around the O.D. of the pilot.
- c. Use the three Sonnax flathead bolts to attach the Sonnax mounting ring to the front cover. The use of Loctite® is recommended on the bolts.
- d. Press fit the Sonnax thrust washer into the pilot. The grooves should be installed into the pilot.

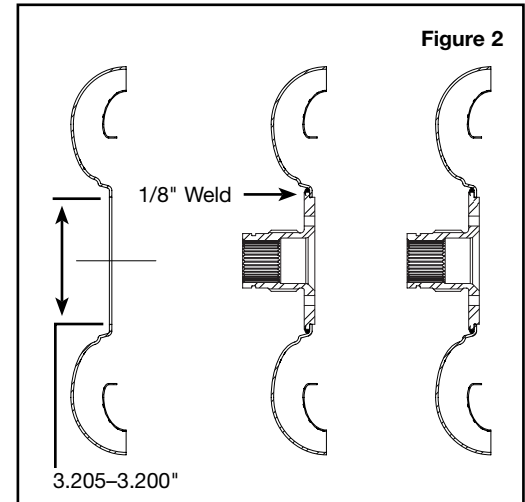

4. Stator Assembly

- a. Install the Sonnax stator race so that the longer neck and larger I.D. chamfer face toward the impeller (fixed side).
- b. Install new springs and rolls.
- c. Install the OE stator cap and snap ring into the stator.

5. Clutch Assembly

The kit is designed to work with early-model GM 245mm model piston/damper assemblies. 4L80-E units with EC³ systems MUST use clutches with woven carbon or High Thermal Engaging (HTE) friction rings.

6. Final Assembly

From this point on the kit can be assembled as any stock GM 245mm converter.

NOTE: High torque applications can overpower the torque capacity of stock GM 245mm single disc clutch and damper assemblies. The ability of this single disc clutch to handle a specific torque load is dependent on many factors, including the amount of input torque and the strategy that is used in applying the torque converter clutch. Sonnax does not guarantee that the capability of the 245mm damper assembly will be adequate in all applications.

