

GM Powerglide, TH350, TH400, 8"

Unit Size: 8" • Core: Opel • Damped: No • Turbine Hub Input Spline Count: 30

8" Performance Converter Kit

Part No. GM-RK-2

- Flanged Impeller Hub
- 30-Tooth Turbine Hub
- Thrust Washer
- Front Cover, Dual Bolt Pattern (Bushing installed)
- Adapter Ring

NOTE: Pilot kit not included.

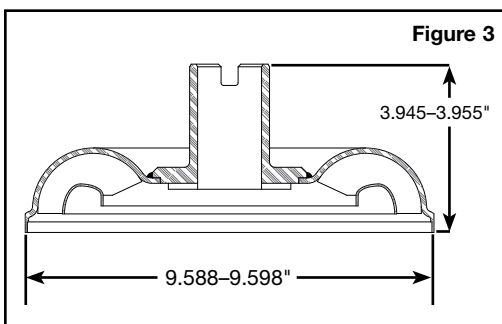
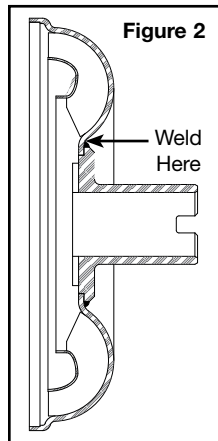
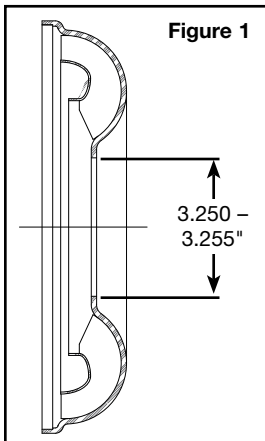
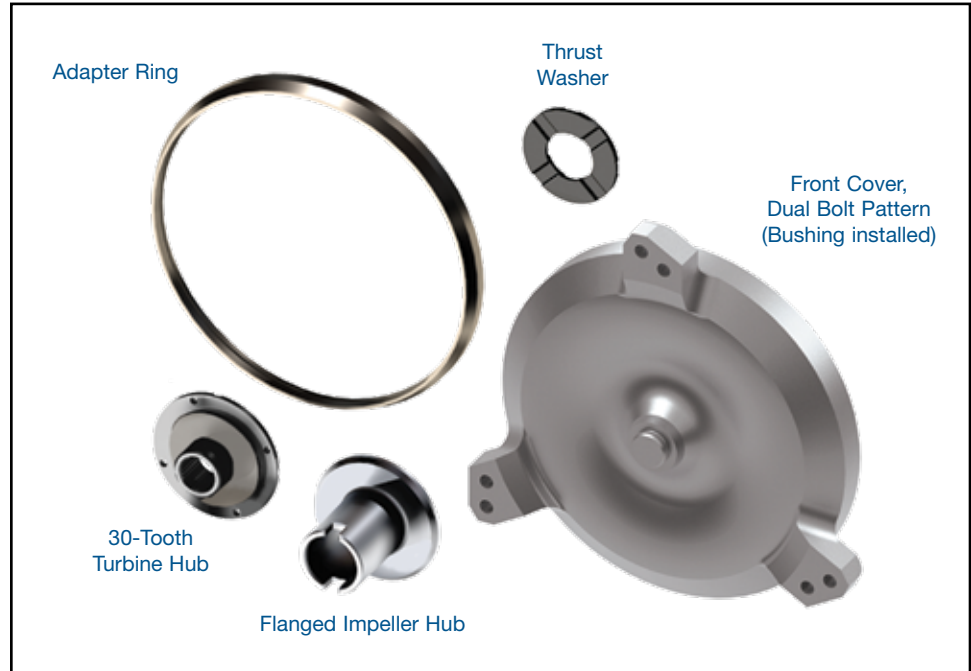

1. Impeller Assembly

- Remove stock impeller hub by boring a 3.250–3.255" dia. hole on-center in the 8" Opel impeller (**Figure 1**).
- Install Sonnax impeller hub from the outside. Weld around O.D. of the impeller hub, ensuring it is centered on the impeller (**Figure 2**).
- Mount impeller assembly in a lathe, ensuring the impeller hub journal diameter runs true. Machine O.D. of the impeller down to 9.588–9.598" dia. and 3.945–3.955" overall height (**Figure 3**).
- Fit Sonnax adapter ring to the impeller assembly and weld (**Figure 4**).

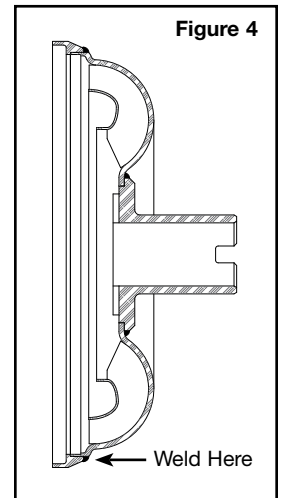

2. Turbine Assembly

- Remove the rivets holding OE turbine assembly together.
- Install Sonnax turbine hub into OE turbine from stator side. Align the four oil flow holes of the hub with rivet holes on turbine. Weld around O.D. of turbine hub (**Figure 5**).

NOTE: If using Sonnax stator **GM-ST-082** or **GM-ST-086**, the stator will be .345" taller than OE stator. Approximately .345" must be removed off the turbine bearing face to correct clearances and stack height.

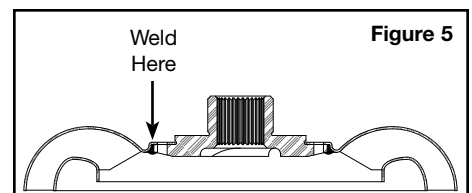

3. Front Cover Assembly

- Apply thread locking compound to internal pilot threads (**Figure 6**).
- Screw pilot onto the threaded pilot of front cover and tighten with pin spanner (**Figure 7**).

NOTE: Due to the taper of the pilot, very little tightening force is necessary.

4. Permanently Attach Spacers

If using mounting pad spacers, secure spacer to the appropriate bolt hole of the front cover using a 7/16"-20 mounting bolt (**Figure 8**). Tack weld spacer in place, then remove bolt (**Figure 9**). Repeat for other mounting pads.

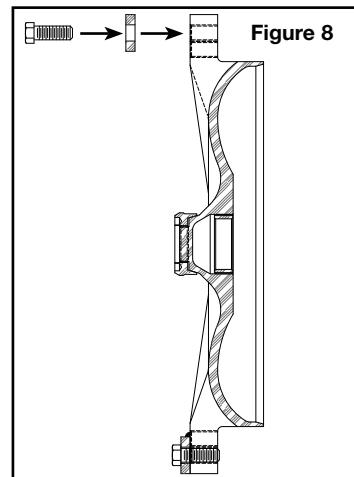
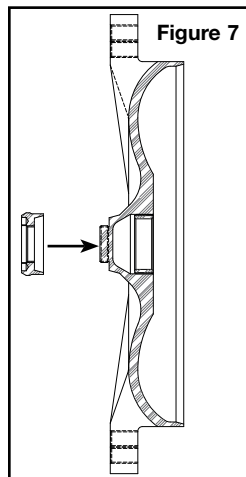
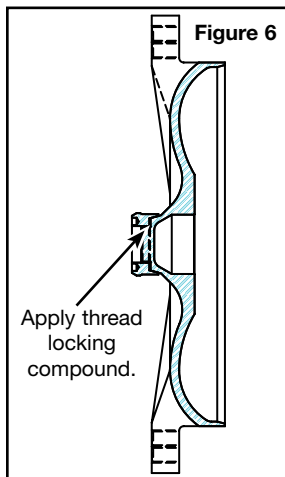

5. Stator Assembly

Install new one-way clutch with appropriate stator caps and bearings (*not included in kit*).

7. Final Assembly

Continue converter assembly. Sonnax thrust washer is included for use during reassembly. Final endplay after welding should be .000-.010", and the stator and turbine assemblies should be able to turn with minimal effort.

