

GM TH400 (3L80); Allison® AT-540

Stator Adapter

Part No.

GM-WA-3

Applications

Convert early-style GM TH400 stator to late-style

Associated Parts

- GM-N-8HLT Thrust Bearing
- GM-90-10G Flanged Impeller Hub



1. Installation Instructions

- Sonnax stator adapter **GM-WA-3** is not a drop in replacement.
- Machine a step into the stator (**Figure 1**) to accept the **GM-WA-3** stator adapter. The stack height of the stator with bearing installed is unchanged from old to new configuration.



NOTE: Care should be taken to keep O.D. and thrust surface true to the axis of the stator. The adapter should press onto the stator with a .011–.033" press fit.

2. Impeller Hub Requirements

The OE impeller hub does not have a flat back-up surface on which to seat Sonnax thrust bearing **GM-N-8HLT**. Install Sonnax flanged impeller hub **GM-90-10G** to create this surface.

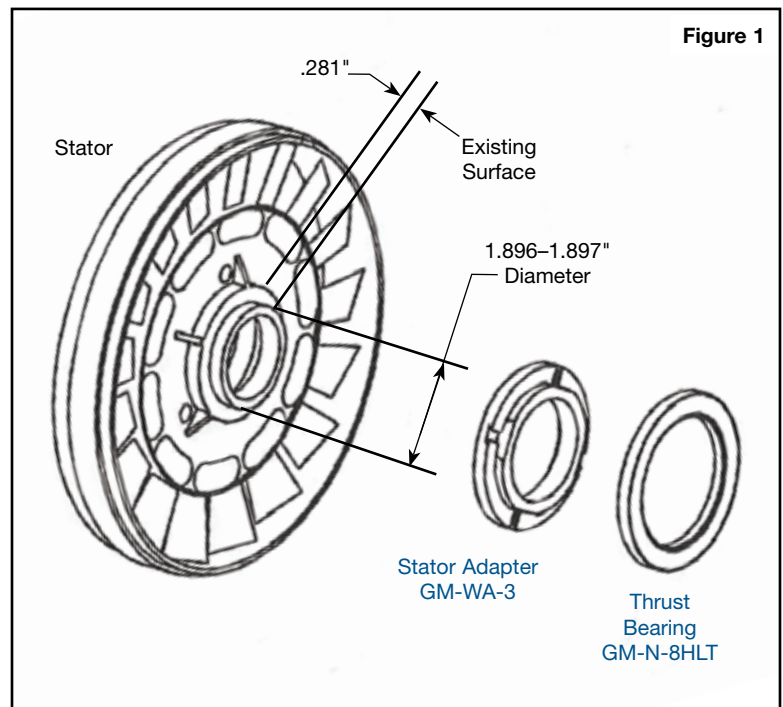

Figure 1