

Pressure Regulator Boost Sleeve

Part No.
93990



WARNING: On RE4F02A units, be sure to compare I.D., O.D., depth, overall length and feed hole locations.

Jatco/Nissan RE4F02A, RL4F02A

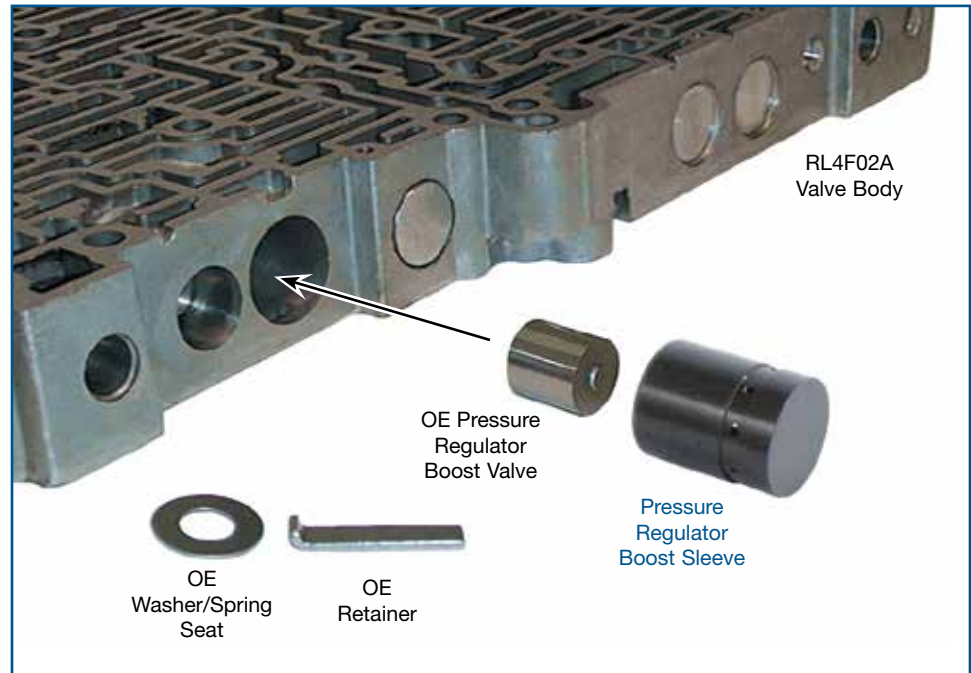

1. Disassembly

- a. Remove OE parts from pressure regulator bore.
- b. Discard OE pressure regulator boost sleeve.
- c. Save all other OE parts for reuse.

2. Installation & Assembly

- a. Be certain all debris has been removed from the valve bore and valve body.
- b. Return all parts, ensuring OE washer is properly seated on OE springs in the valve body bore.
- c. Insert OE pressure regulator boost valve into Sonnax pressure regulator boost sleeve.
- d. Insert pressure regulator boost valve and sleeve assembly into the valve body bore, just far enough to return the retainer.

3. Final Testing

Vacuum testing at the port(s) indicated holds the recommended minimum 18 in-Hg.

