

## New Process 230 & 240 Series

### Split Ring Retainer

**Part No.**

**100420-02K**

- Snap Ring
- Retainer Ring
- Split Retainer

**NOTE:** 230 and 240 series with 1.375" dia. shaft.

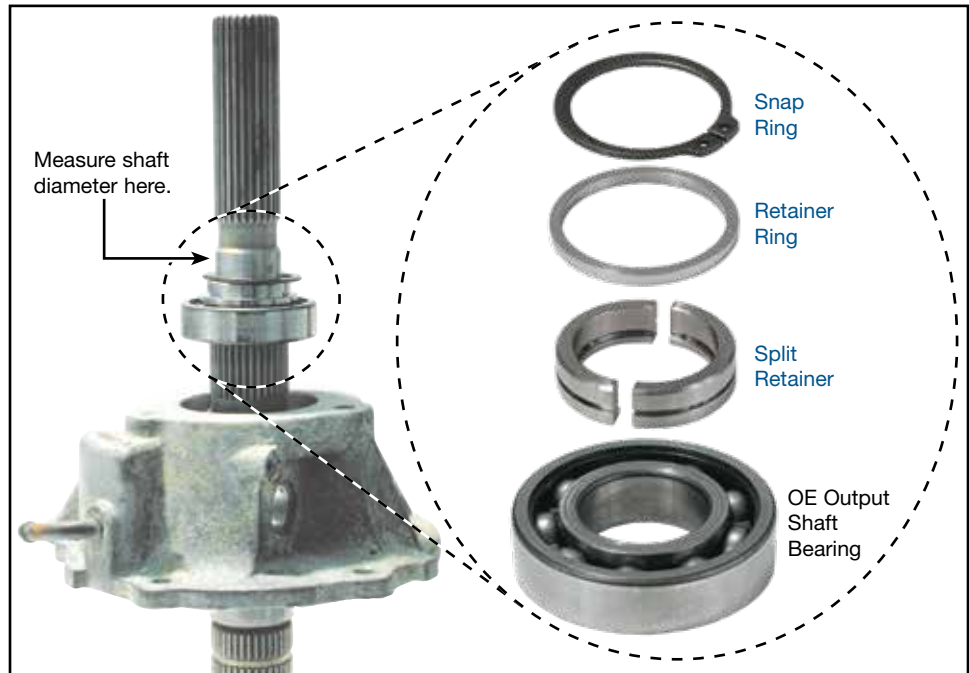

#### 1. Disassembly

Remove OE retaining ring.

#### 2. Installation & Assembly

- Place the two halves of the split ring retainer around the output shaft.
 

**NOTE:** The end of the retainer with the chamfer on the O.D. should face away from the bearing.
- Place the solid retaining ring over the split retainer. Slide it over the split retainer until it is in contact with the bearing.
- Install the snap ring into the groove on the split ring retainer. This will keep the assembly together (**Figures 1 & 2**).

