

Ratcheting End Plug

Part No.

119940-22



Recommended

Adjustment Tool

Part No.

119940-TL9

- Reamer
- Reamer Jig
- Guide Pin

NOTE: This tool is not required but is highly recommended to allow removal or adjustment without breaking the end plug arms.

WARNING: Recommended tool kit 119940-TL9 is no longer in production. Check with your distributor for availability.

VW/Audi 096, 097, 098, 01M, 01N, 01P

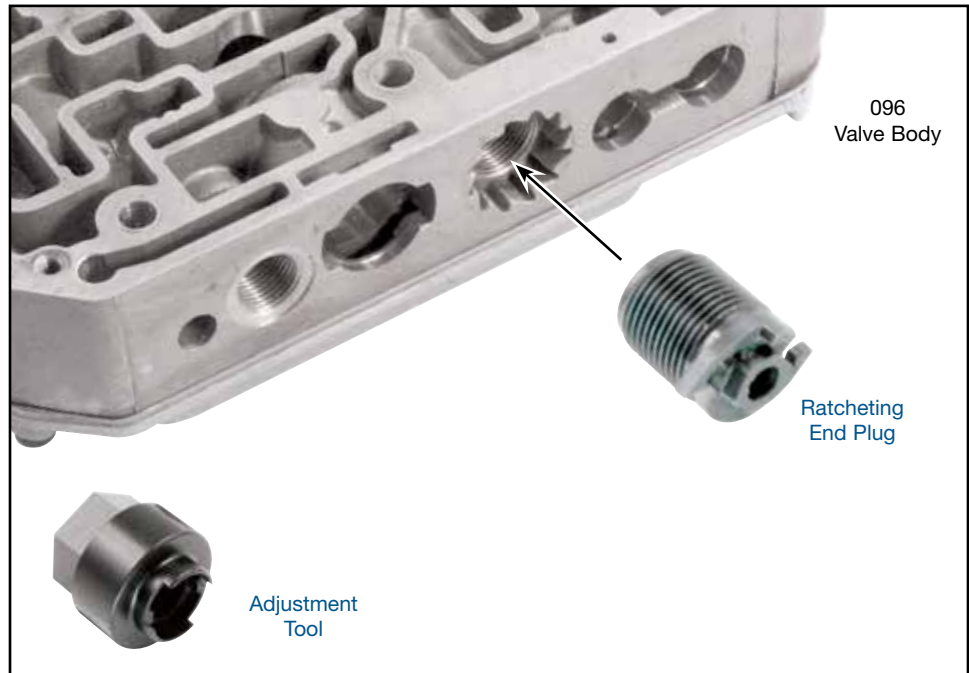

1. Disassembly



NOTE: Prior to removing the ratcheting end plug from the bore, measure and note how deeply it is installed. The replacement plug should be installed to this same depth to ensure proper line pressure control. The most accurate method is to insert a slide caliper rod through the hole in the plastic plug until it bottoms against the control valve. Bring the caliper end toward the plug until flush. This gives you the spring height adjustment from the plug to the valve. Record this measurement before removing the plug and duplicate this distance during reassembly to most accurately duplicate the spring compression setting. If your caliper will not pass through the hole, measure from the valve body casting surface to the outer face of the OE plug and duplicate later.

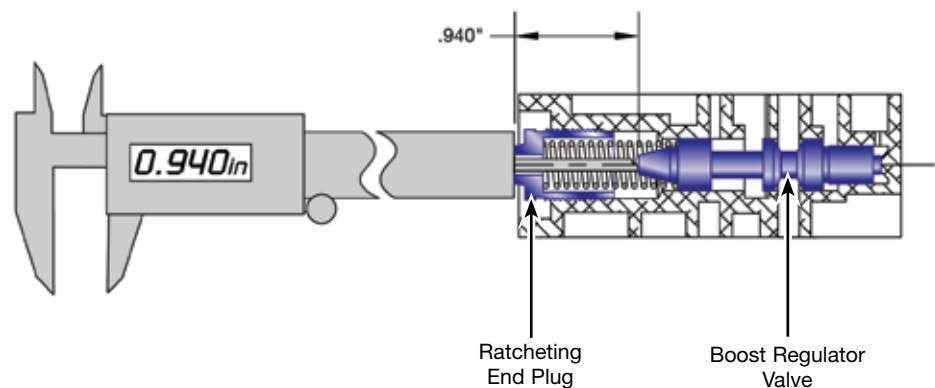

1. Disassembly (continued)

- a. Remove OE ratcheting end plug from bore by gently inserting cam end of Sonnax tool into valve body bore and over the end of OE end plug.
- b. Carefully rotate Sonnax tool counter-clockwise until tool seats fully against the plug and the anti-rotational tabs are enclosed fully in the cam.
- c. Continue rotating Sonnax tool to the left, until OE end plug is removed from the bore. The tool has a 3/4" hex head so a socket or wrench can be used.



NOTE: This bore should be inspected for wear on every rebuild. The worn bore can be salvaged using Sonnax oversized boost regulator valve **119940-05K** for 01M, 01N and 01P units.

2. Installation & Assembly

- a. Install the end plug, thread into the bore until the pre-measured height is again achieved.
- b. Adjustments to the base setting may be required due to variations in the plug, valve body or improvements from either regulator bore. Initial setting on average OE parts is .940", measured from the end of the valve to the outer face of the plastic adjuster. Turning the adjuster clockwise will increase boost pressure, line pressure and create firmer engagements as well as upshifts and downshifts. Turning counter clockwise reduces line pressure at idle and results in softer shifts. Each turn is approximately 8 psi alteration. One turn is drastic and we suggest you go by 1/2 to 1/4 turns. The outcome of this adjustment is monitored at line pressure tap.
- c. A 5/16" socket may be used while threading the plug into the bore. However, the tool will be needed to turn the plug back out while adjusting to the correct setting.
- d. It is very important to verify line pressure when installation is complete. OE line in Drive is generally 50-56 psi. Reverse is 95-110 psi at idle. To obtain firm engagements or reduce flare, increase to line in Drive to 60 psi (1/2-turn clockwise). Readjust if not within this range.



NOTE: OE line pressure port is a straight 10 x 1.0mm thread with a flanged plug. A line pressure adapter can be made from a common 1/8th NPT 45-degree adapter. Chase male thread on the adapter with 10 x 1.0 thread die. Gently screw adapter into the case and then screw pressure gauge into adapter.