

## Oversized Piston Retainer Kit

**Part No.**  
**12962N-02K**

- Piston Retainer 6 Bolt
- O-Ring
- Plugs (2)

Patent 6,810,771

## Chrysler 42RE, 42RH

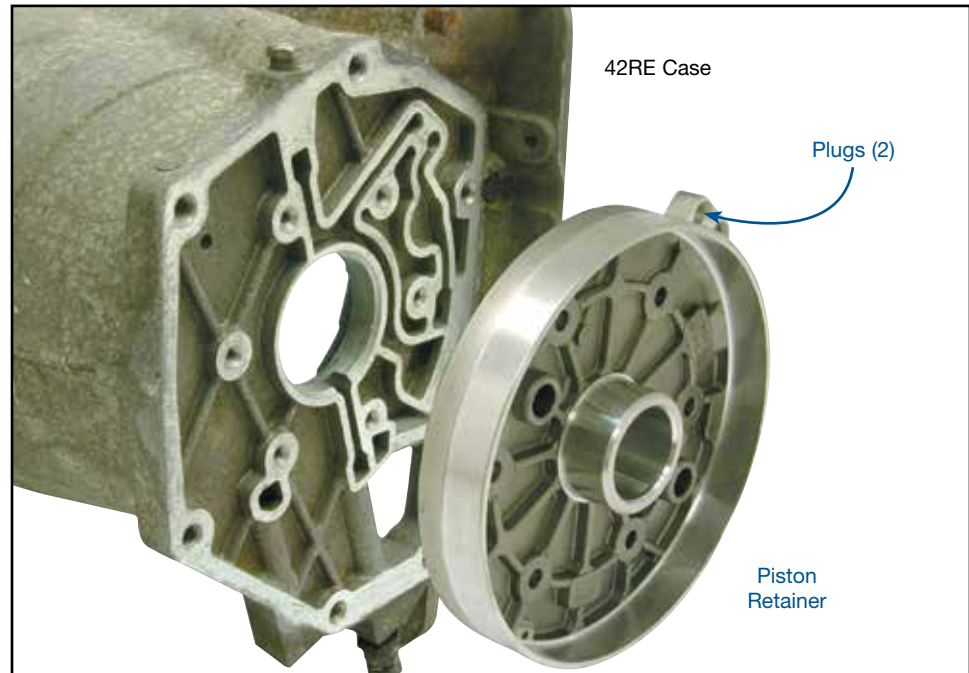

### 1. Preparation

- a. If Sonnax oversized piston retainer kit is being used, turn the reverse drum I.D. to 1.966–1.967".
- b. It is important to achieve a surface finish of 16 Ra (comparable to a ground finish) or smoother to increase the life of the unit.
- c. It is recommended that you drill a small .040–.045" hole in the case to help lubricate the low roller clutch (Figure 1).



**NOTE:** This process is not a requirement to use the Sonnax retainer.

### 2. Installation & Assembly

- a. Install Sonnax O-ring into O-ring groove and lubricate with TransJel® (Figure 2).

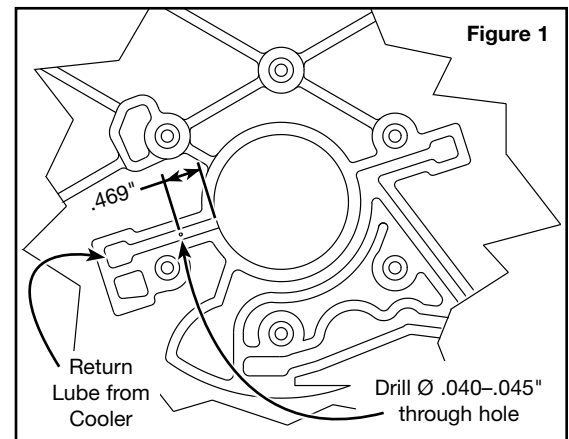

Figure 1

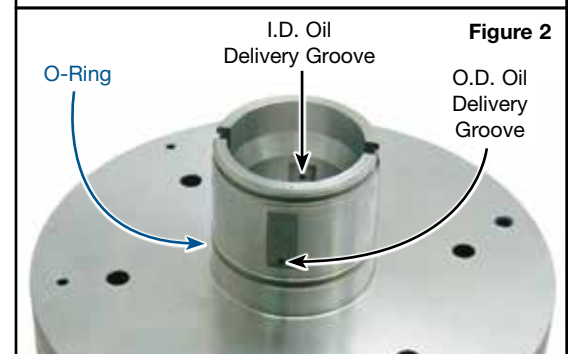

Figure 2

### 2. Installation & Assembly (continued)

- b. If the retainer is being installed on an 46RE unit, press two Sonnax aluminum plugs into the governor tube holes (Figure 3).



**NOTE:** Do not install plugs on RH units, only in RE units.

- c. Assemble the transmission following normal OE procedures.

### 3. Final Testing

Sonnax Sonnaflow™ should be used to verify cooler flow after the rebuild (Figure 5).

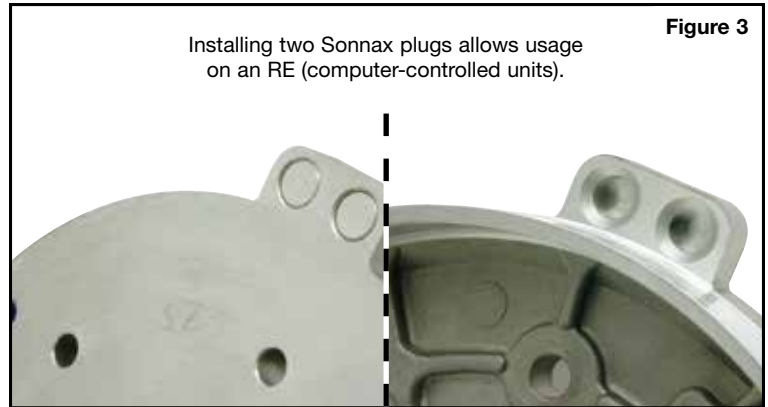

Figure 3

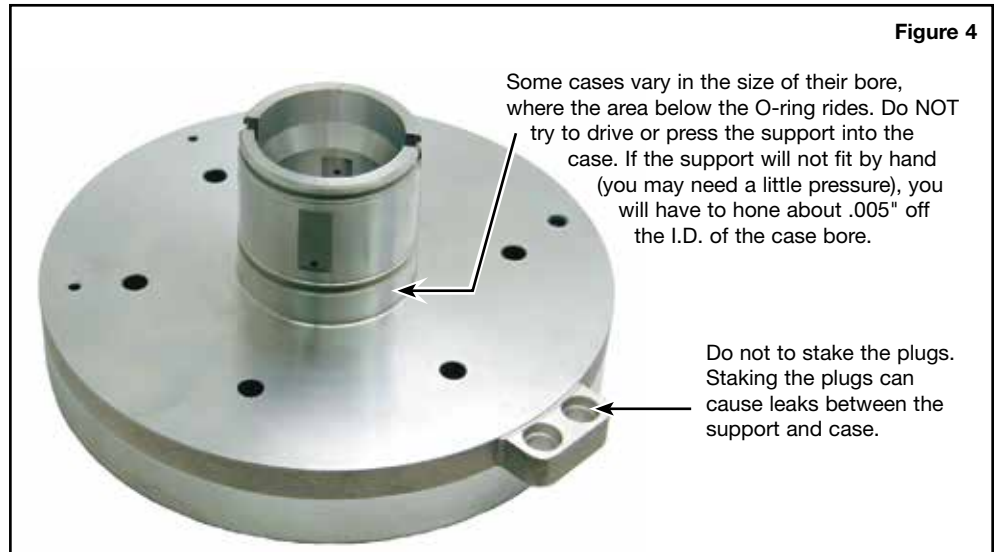

Figure 4

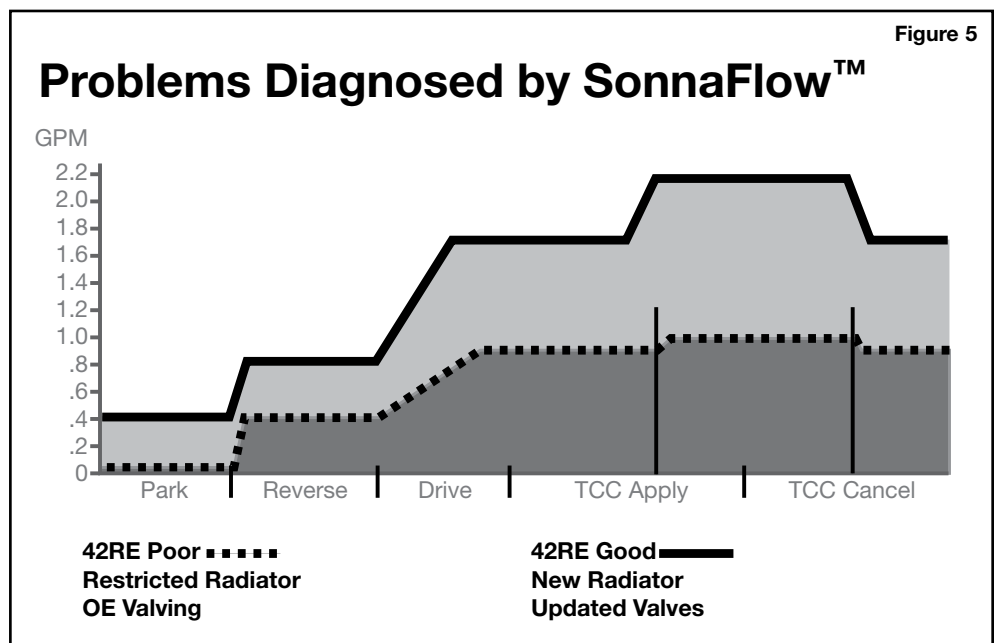

Figure 5