

## Oversized Piston Retainer Kit

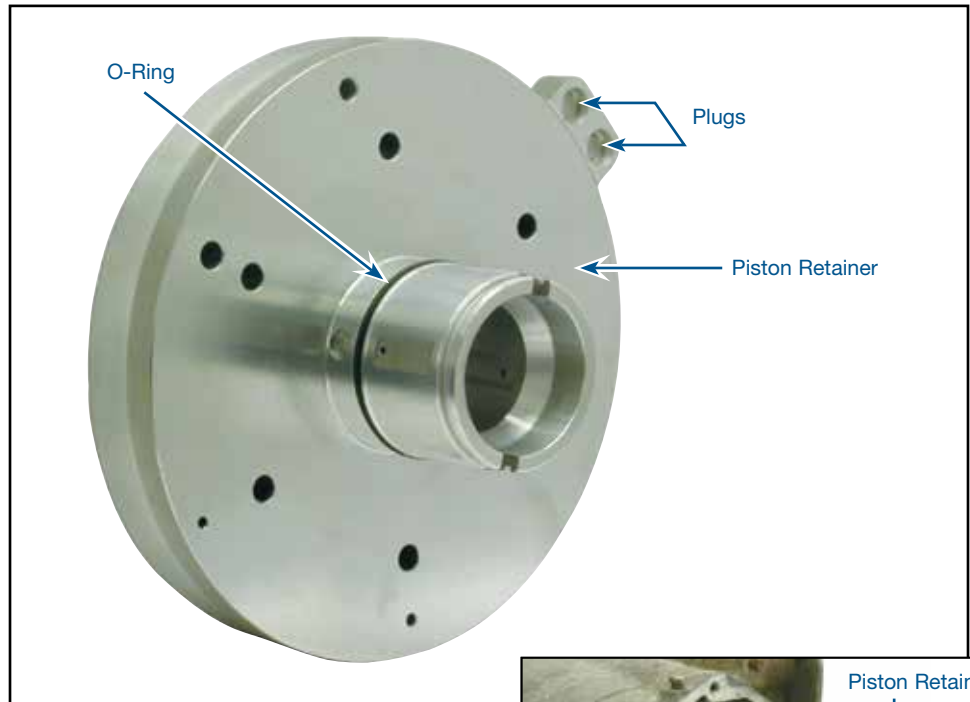


**Part No.**  
**22754N-02K**

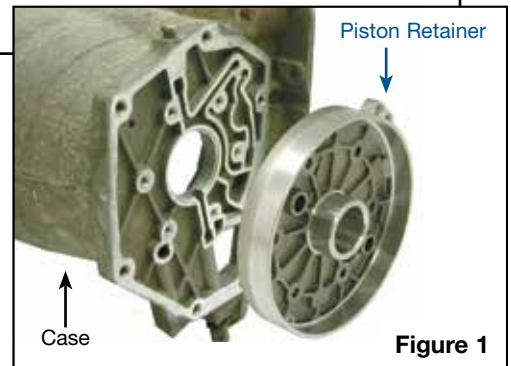
- Piston Retainer
- O-Ring
- Plugs (2)

Patent No. 6,810,771

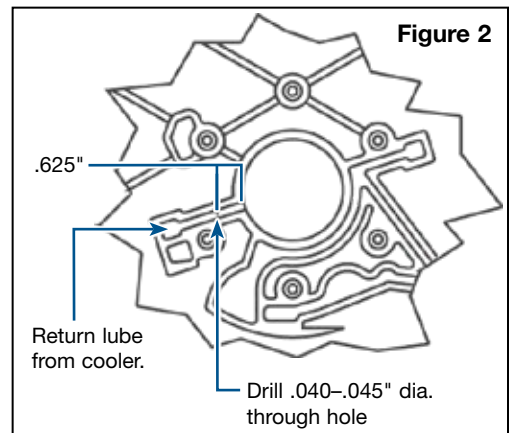
## Chrysler 46RE, 46RH, 47RE, 47RH, 48RE



1. Turn the reverse drum inner diameter to 2.1885/2.1875". It is important to achieve a surface finish of 16 Ra (comparable to a ground finish) or smoother to increase the life of the unit.
2. It is recommended that you drill a small .040-.045" hole in the case to help lubricate the low roller clutch. See **Figure 2** for the exact location of the hole. This process is not a requirement to use the Sonnax retainer.
3. Install the O-ring into the O-ring groove and lubricate with TransJel.

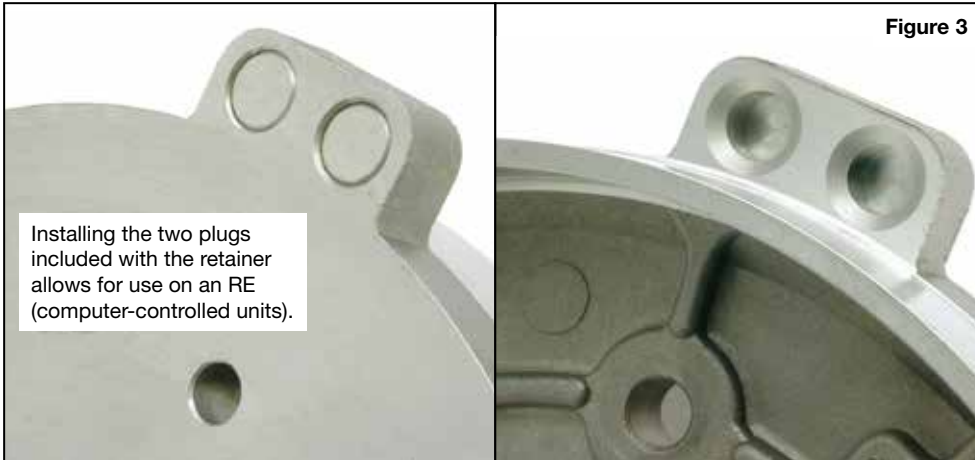


**Figure 1**

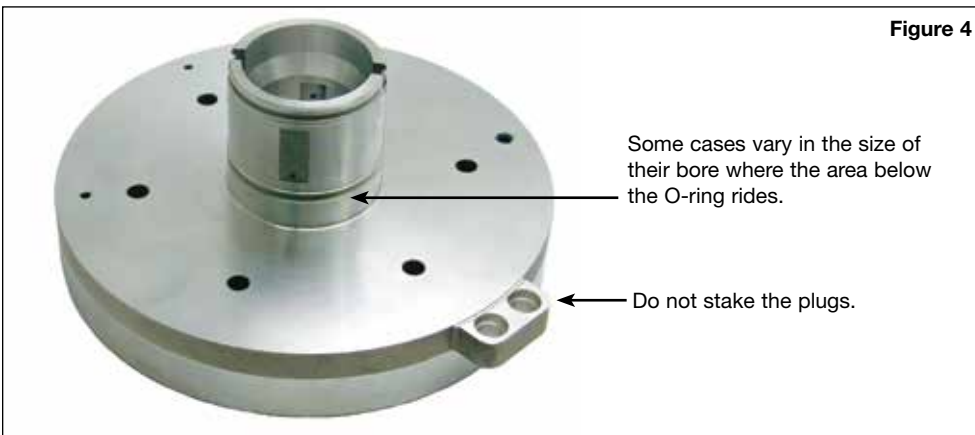


**Figure 2**

4. If the retainer is being installed on a RE unit, press the two aluminum plugs into the governor tube holes (**Figure 3**).



- Some cases vary in the size of their bore where the area below the O-ring rides. You should not try to drive or press the support into the case. If the support will not fit by hand (you may need a little pressure), you will have to hone about .005" off the I.D. of the case bore (**Figure 4**).
- Do not stake the plugs, staking the plugs can cause leaks between the support and case.



5. Assemble the transmission following normal procedures.