

Lube Regulated Pressure Regulator Valve

Part No.

22771A-10K

NOTE: Fits '62-'77 units only. No valve body modifications required.

Patent No. 6,712,726

Chrysler A727, A904

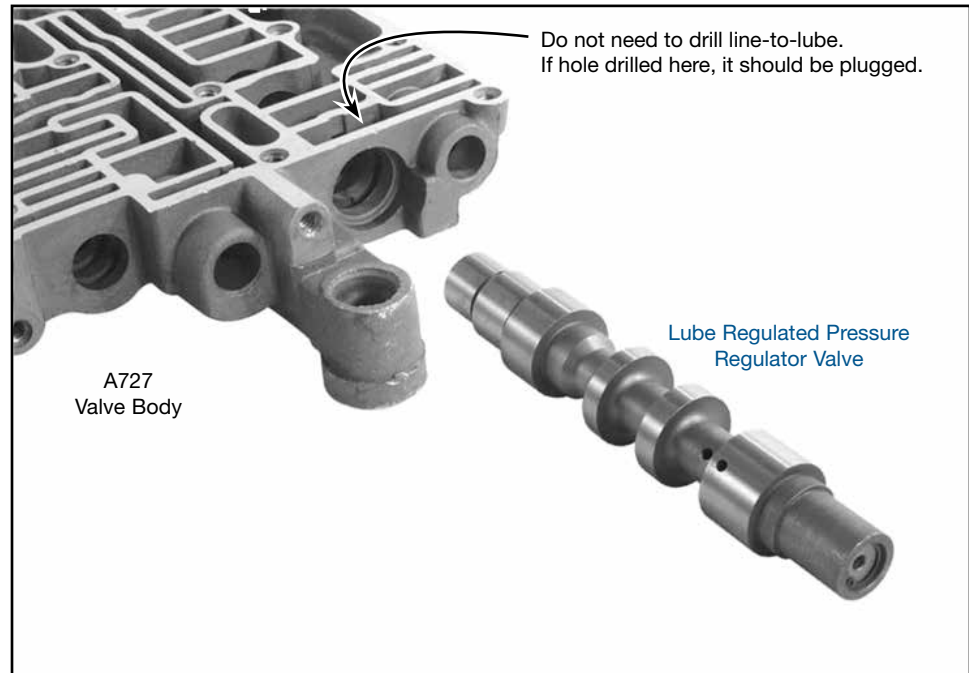

1. Valve Body Inspection (Figure 1)

- If a line-to-lube hole has been drilled in the pressure regulator valve circuit, it should be plugged to reduce converter drainback.
- Inspect the line pressure plug and sleeve. Leakage here will result in poor line pressure control.

2. Disassembly

- Remove OE detent assembly and spring retainer bracket (Figure 2).
- Remove OE pressure regulator valve.

3. Installation & Assembly

- Install Sonnax lube regulated pressure regulator valve.
- Adjust OE pressure regulation spring for correct line pressure (Figure 3).



IMPORTANT: Line pressure should be set to 54-60 psi at idle with minimum TV.

- Line pressure should be verified with a gauge after installation (pressure tap on passenger side, middle of case, between accumulators).

