

Chrysler 42RE, 42RH, 44RE, 44RH, 46RE, 46RH, 47RE, 47RH, 48RE, A727, A904

Intermediate Accumulator Sleeve Kit

Part No.

22841-01K

- Accumulator Piston
- Sleeve Small
- Sleeve Large
- Seal Small
- Seal Large

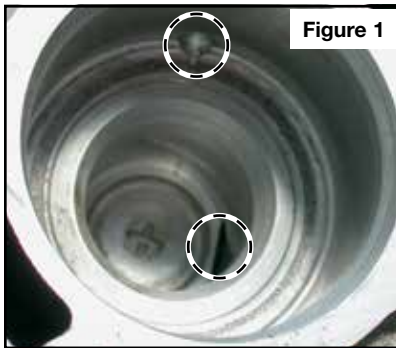
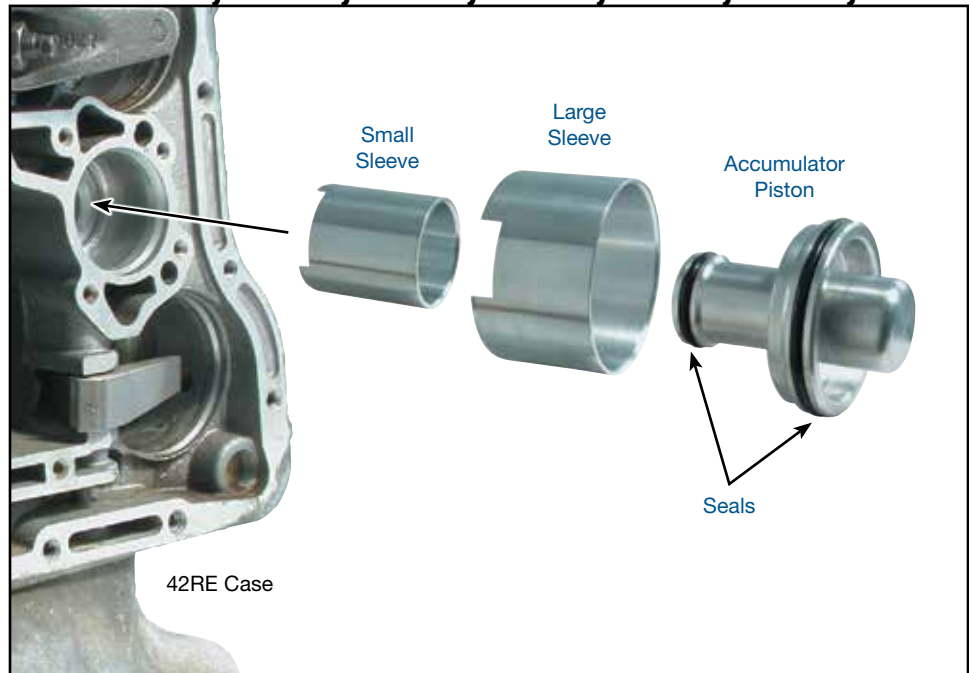

Figure 1

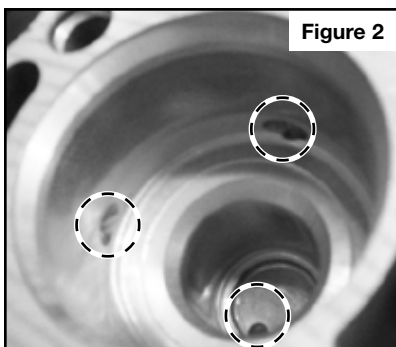

Figure 2

1. Disassembly

Remove any raised metal on either accumulator bore.

2. Bore Preparation

- a. Clean bore thoroughly to remove any dirt, grit or grease and remember to use a Loctite® compatible solvent.
- b. Scuff the O.D. of the sleeves to allow better Loctite® adhesion.
- c. Apply Loctite® 660 into any deep gouges in the smaller bore, then apply a thin coat of Loctite® around the smaller sleeve.

3. Installation

- a. Align the sleeve cutout with the feedhole coming in from the side of the bottom of the bore (**Figure 1**). Some applications will have the feedhole coming up from the bottom of the bore; in this case the sleeve does not need to be indexed (**Figure 2**).
- b. Using a properly sized arbor, carefully drive in the small sleeve.
- c. Repeat steps a–b to install the large sleeve into the large bore.
- d. Allow Loctite® to cure following the manufacturer's instructions.
- e. Install the Sonnax piston following normal build procedures.

NOTE: If the unit has a spring at the small diameter of the accumulator piston, it must be discarded. The spring will not fit into the Sonnax piston.