

## K3 Clutch Control Valve Kit



Part No.

**25741-08K**

- Sleeve
- Valve
- Spring

## Tool Kit



Part No.

**F-25741-TL8**

- Reamer
- Reamer Jig
- Guide Pin

**NOTE:** Sonnax “F-Tool” kits designed to service a specific bore require the VB-FIX, a self-aligning valve body reaming fixture. More information and instructions can be found online at [www.sonnax.com](http://www.sonnax.com).

## Aisin AW TR-60SN; VW/Audi 09D

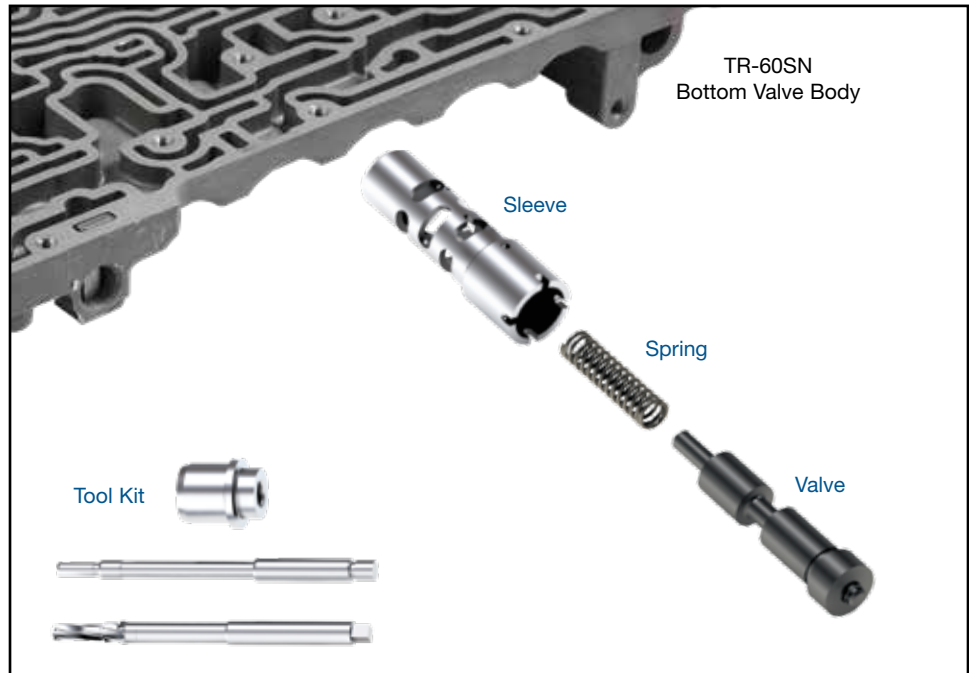

### 1. Disassembly

- Measure and record the distance from the end of the adjuster to the valve body casting (**Figure 1**).
- Remove and save solenoid retaining, solenoid, adjuster retainer and adjuster for reuse.
- Remove and discard OE valve and spring.

### 2. Bore Reaming

Ream K3 clutch control bore (for reaming instructions/reamer care, please visit [www.sonnax.com](http://www.sonnax.com)). Sonnax reaming tool kit **F-25741-TL8** and **VB-FIX** are required for this operation.

### 3. Installation & Assembly

- Install adjuster to position previously recorded during disassembly procedure, followed by retainer.
- Install Sonnax spring into the adjuster pocket.
- Install Sonnax sleeve and valve, ensuring spring I.D. goes over valve nub. Small sleeve and valve diameters should be installed nearest to adjuster.
- Reinstall the solenoid and solenoid retaining pin.

### 4. Final Testing

Vacuum testing at the port(s) indicated holds the recommended minimum 18 in-Hg.

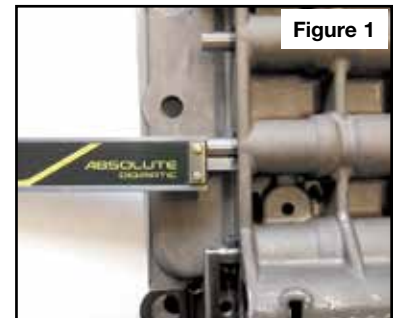

Figure 1

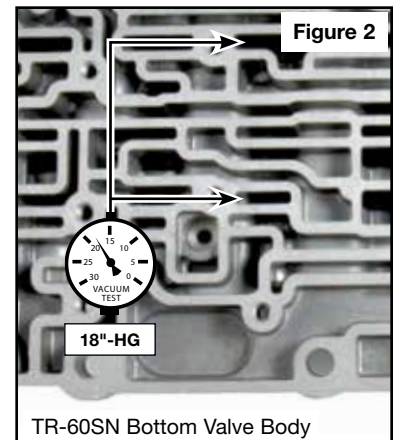

Figure 2