

## Lockup Clutch Control Valve Kit

**Part No.**  
**25741-29K**



- Lockup Clutch Control Valve
- Lockup Clutch Control Sleeve
- Plunger Valve
- Plunger Sleeve
- Plunger Spring

## Tool Kit

**Part No.**  
**F-25741-TL29**



- Reamer
- Reamer Jig
- Guide Pin

**NOTE:** Sonnax “F-Tool” kits designed to service a specific bore require the VB-FIX, a self-aligning valve body reaming fixture. More information and instructions can be found online at [www.sonnax.com](http://www.sonnax.com).

## Aisin AW TR-60SN; VW/Audi 09D

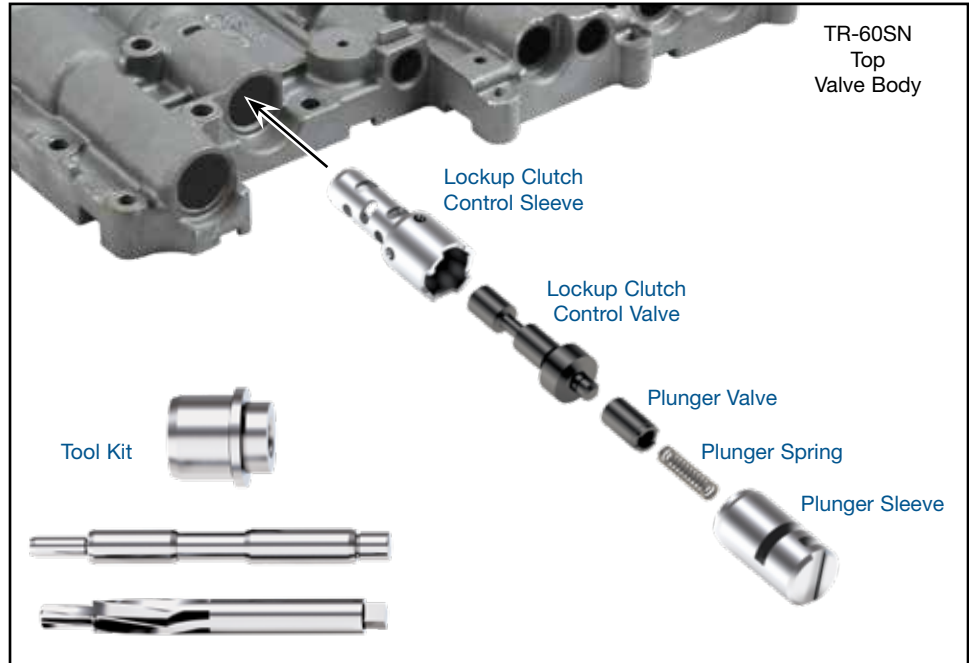

### 1. Disassembly

- Remove OE retainer and save for reuse.
- Remove and discard OE plunger sleeve, valve and spring assembly and lockup valve.

### 2. Bore Reaming

Ream lockup clutch control bore (for reaming instructions/reamer care, please visit [www.sonnax.com](http://www.sonnax.com)). Sonnax reaming tool kit **F-25741-TL29** and **VB-FIX** are required for this operation.

### 3. Installation & Assembly

- Be certain all debris has been removed from the valve bore and valve body.
- Insert Sonnax lockup clutch control valve and sleeve assembly into reamed bore with the smaller sleeve O.D. inboard.
- Insert Sonnax plunger spring into the plunger sleeve, followed by the plunger valve.
- Install plunger assembly into reamed bore with the sleeve's open end inboard.
- Reinstall OE retainer.



**NOTE:** If the stack-up of components does not allow installation of OE retainer, carefully remove the minimum necessary material from the open, or inboard end, of the plunger sleeve. Be sure to remove any burrs which may interfere with plunger valve movement.

### 4. Final Testing

Vacuum testing at the port(s) indicated holds the recommended minimum 18 in-Hg.

