

Boost Valve Kit

Part No.

34200-10K

- Valve
- Sleeve
- O-Rings (2)

Patent 6,776,736

GM 4L80-E, 4L85-E

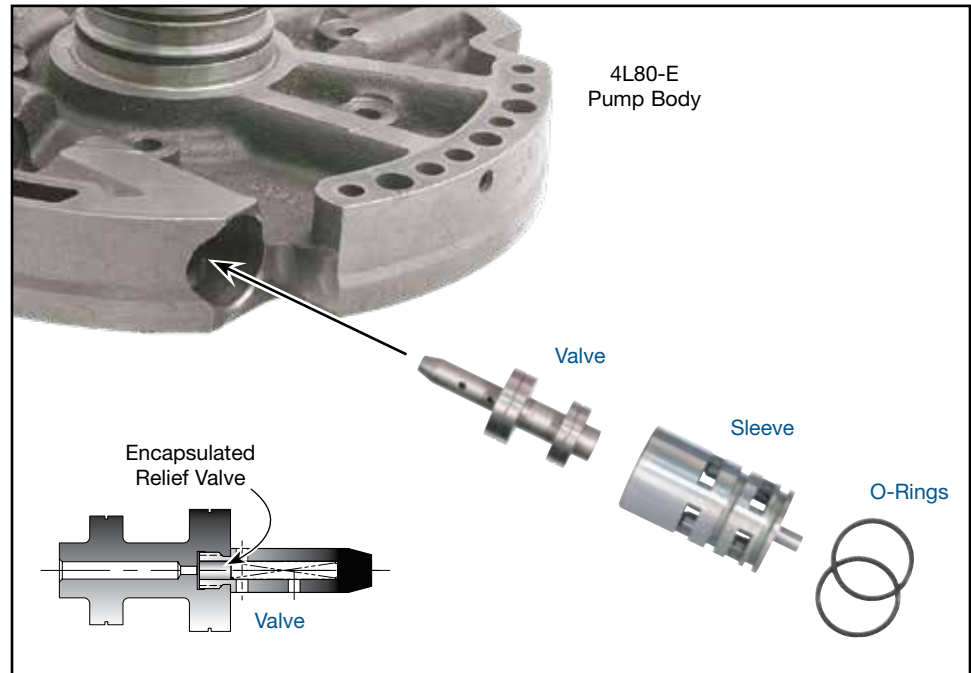

1. Disassembly

- Remove OE retainer clip and set aside for reuse.
- Remove OE boost lineup and discard.

2. Installation & Assembly

- Be certain all debris has been removed from the valve bore and pump cover.
- Install Sonnax O-rings onto grooves in Sonnax sleeve.
- Lube O-rings with ATF and roll on bench to size.
- Insert Sonnax valve into Sonnax sleeve with long stem facing out and secure with OE retainer clip.

3. Final Testing

- Reassemble pump halves.
- Vacuum testing at the port(s) indicated holds the recommended minimum 18 in-Hg.

