

## Aisin AW55-50SN, AW55-51SN

### Shift Pressure Control Valve Kit

#### Part No.

# 59947-38K

- Valve
- Sleeve

**NOTE:** Also fits AF23/33 and RE5F22A units.

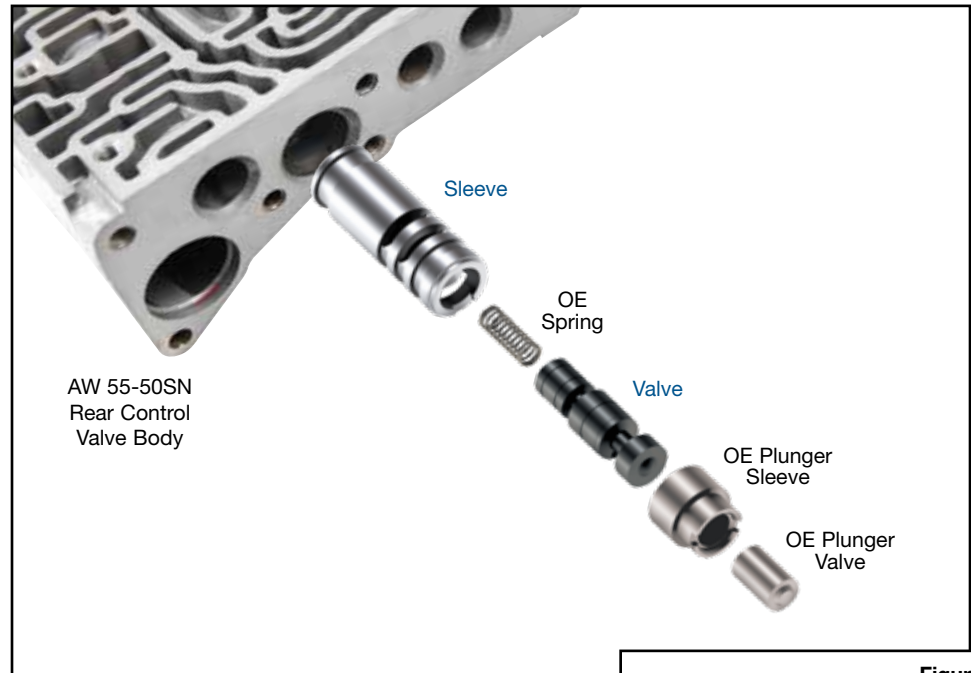

### 1. Disassembly

- Remove OE valve lineup.
- Discard OE shift pressure control valve and sleeve.
- Save OE spring, plunger valve and sleeve for reuse.

### 2. Installation & Assembly

- Place OE spring into spring pocket of Sonnax valve.
- Install this spring and valve assembly into Sonnax sleeve, spring end first.
- Install this valve, sleeve, spring assembly into the bore, with the open end of the sleeve outboard.

**NOTE:** Rotational clocking of the sleeve in the bore is not critical, but for best results install with Drive/Reverse and clutch feed slots upward and visible through the casting ports as illustrated (Figure 1).

- Reinstall OE plunger valve and sleeve assembly. Secure with OE plate and bolts.

### 3. Final Testing

Vacuum testing at the port(s) indicated holds the recommended minimum 18 in-Hg (Figure 2).

