

1-2, 4-5 Overlap Control Sleeve Kit

Part No.

68942-02

- Sleeve
- O-Ring

Mercedes 722.6

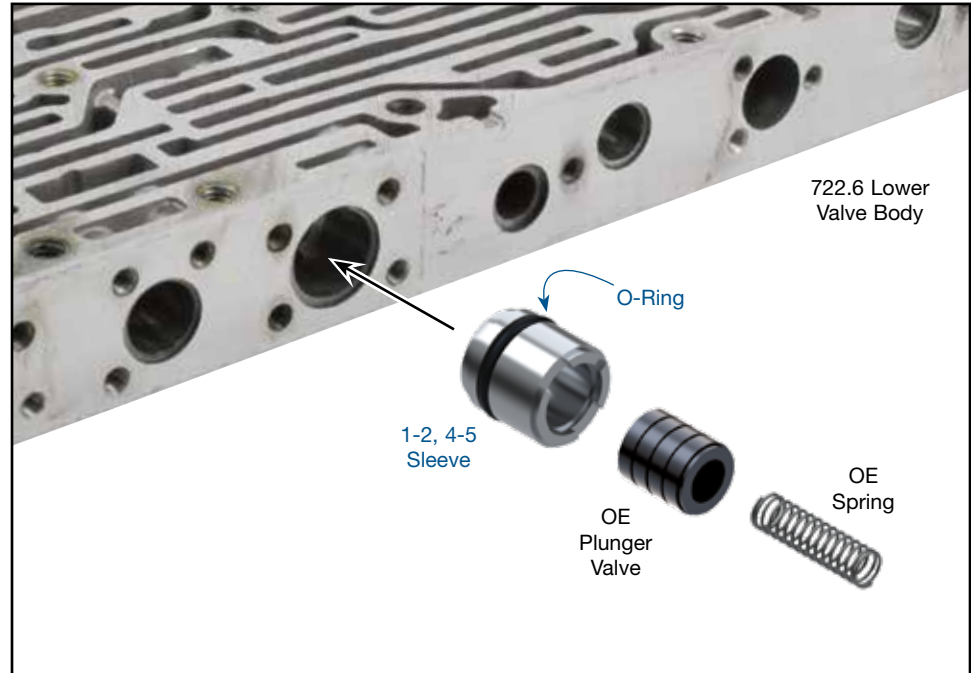

1. Disassembly

- Remove OE screws and end plate, saving for reuse.
- Remove OE spring and plunger valve, saving for reuse.
- Remove and discard OE sleeve.

2. Installation & Assembly

- Install Sonnax O-ring into shallow groove of Sonnax sleeve and roll on bench to size. Lubricate sleeve and O-ring.
- Reinstall OE spring into plunger valve spring pocket, referencing chart. Slide plunger valve into Sonnax sleeve, with spring facing grooved end face of Sonnax sleeve.
- Slowly install Sonnax sleeve assembly into valve body bore, taking care not to shear O-ring. Ensure sleeve end face grooves are outward.

3. Final Testing

Vacuum testing at the port(s) indicated holds the recommended minimum 18 in-Hg.

NOTE: Ensure that OE springs are returned to their correct locations. For location, spring free length and the spring load at full stroking height of inner valve see chart.

OE Spring	Free Length	Spring Load	Sonnax ID Grooves
1-2, 4-5 Overlap	.817"	1.5 lbs.	1
2-3 Overlap	.654"	11.4 oz.	2
3-4 Overlap	.790"	1.2 lbs.	3

