

Oversized Manual Valve

Part No.
68942-16



Tool Kit

Part No.
F-68942-TL16



- Reamer
- Reamer Jig
- Guide Pin

NOTE: Sonnax “F-Tool” kits designed to service a specific bore require the VB-FIX, a self-aligning valve body reaming fixture. More information and instructions can be found online at www.sonnax.com.

WARNING: Required tool kit F-68942-TL16 is no longer in production. Check with your distributor for availability.

Mercedes 722.6

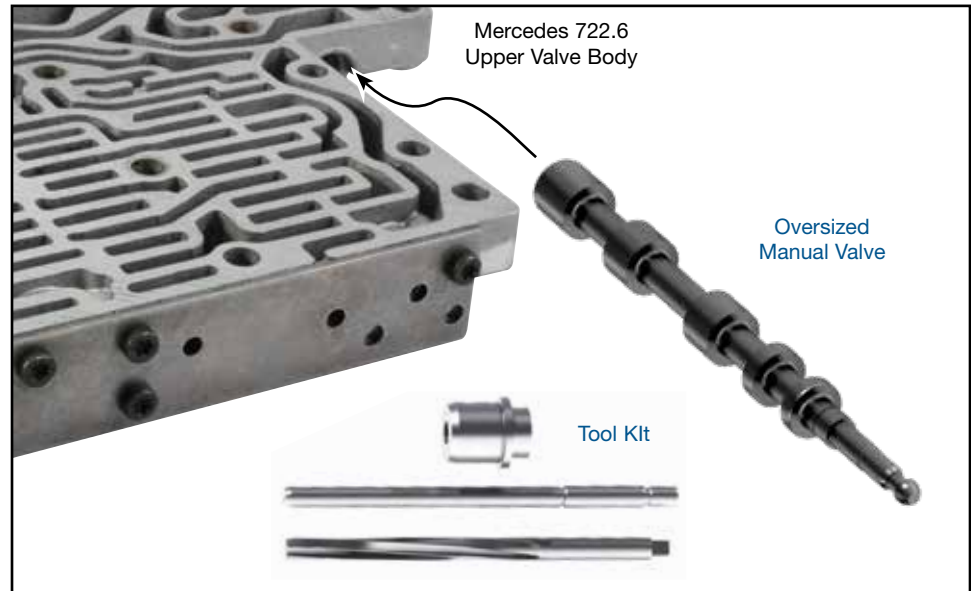

1. Disassembly

- Remove OE plastic linkage connector from end of OE manual valve using a small flat-blade screwdriver to carefully pry up the retaining arm of the connector (**Figure 1**).
- Pull manual valve out of the connector and discard. Save the plastic connector for reuse with Sonnax manual valve.

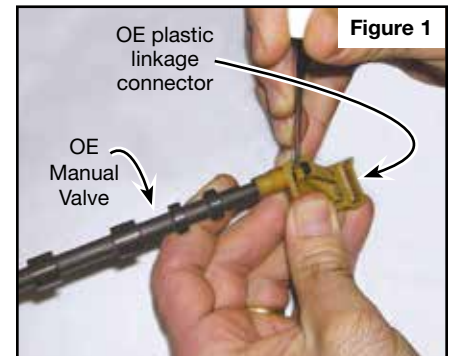

2. Bore Reaming

Ream manual valve bore (for reaming instructions/reamer care, please visit www.sonnax.com). Sonnax reaming tool kit **F-68942-TL16** and **VB-FIX** are required for this operation.

3. Installation & Assembly

- Install the OE linkage connector onto Sonnax oversized manual valve.
- Vacuum test prior to final assembly with transmission case.
- Install the valve body onto the transmission case and assemble the selector linkage connection per accepted procedures.

4. Final Testing

Vacuum testing at the port(s) indicated holds the recommended minimum 14 in-Hg.

