

Bypass Clutch Control Plunger Valve Kit

Part No.

76948-04K

- Sleeve
- Valve

Ford 4R70E, 4R70W, 4R75E, 4R75W, AODE

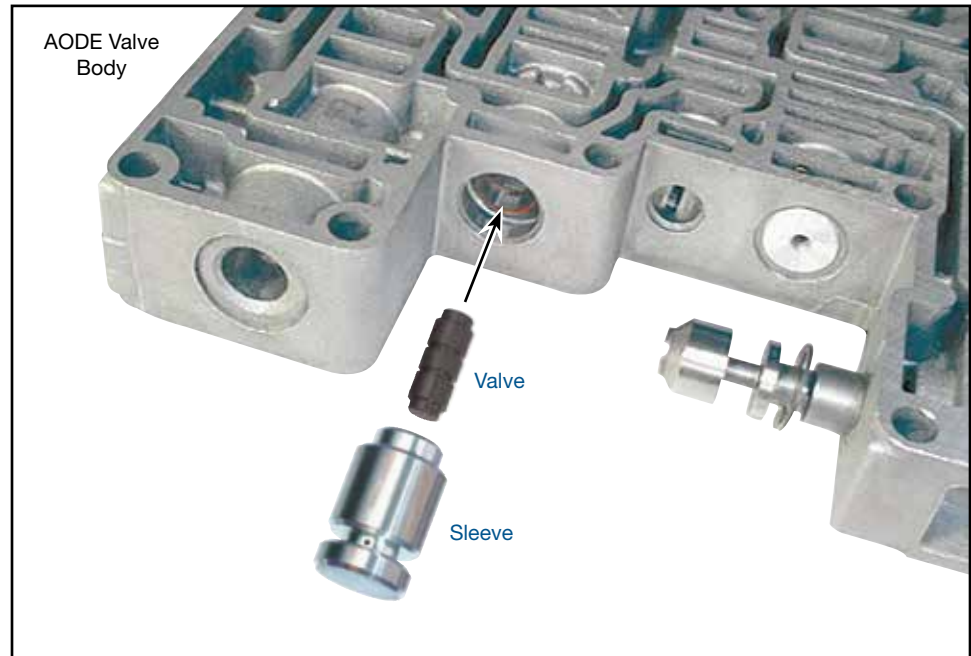

1. Disassembly

- Remove OE retainer and set aside for reuse.
- Remove OE bypass clutch control sleeve and plunger valve from valve body and discard.

2. Installation & Assembly

- Prepare Sonnax valve and sleeve as directed below:
 - **1995-Earlier:** For firmer, quicker TCC apply, install Sonnax sleeve as is. For OE TCC apply feel, drill through existing Sonnax sleeve orifice hole and out through the other side of the sleeve using a 1/16" drill bit.
 - **1996-Later:** To prevent harsh TCC apply or engine lugging, drill through existing Sonnax sleeve orifice hole as outlined above.
- Install Sonnax valve and sleeve, securing with OE retaining clip, ensuring not to block sleeve orifice hole.
- Use a Sharpie® pen on the back of Sonnax sleeve and align the arrow head with the single orifice hole and place at 6 o'clock (**Figure 1**).
- If the modification in step 2a will be done, draw a line on the back of the sleeve indicating the two orifice hole locations and place sleeve at 3 and 9 o'clock positions (**Figure 2**).

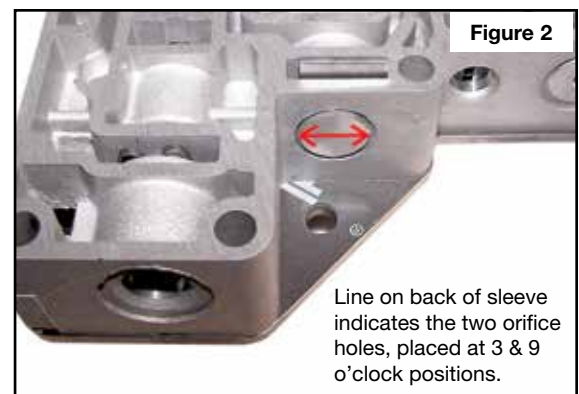
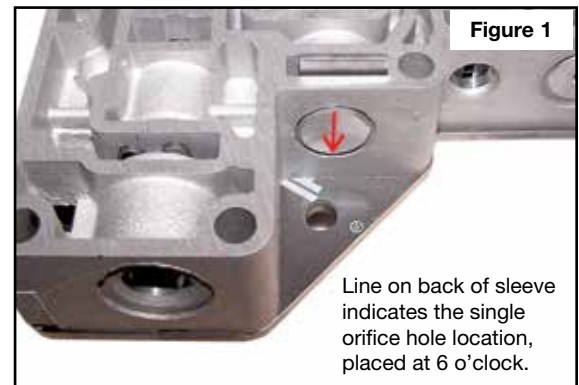

3. Separator Plate Modifications

Ensure bypass/TCC system has full control by drilling holes marked “A” and “B” to .062”. Note that orifice “B” may already be enlarged in some applications (Figure 3).

4. Final Testing

Vacuum testing at the port(s) indicated holds the recommended minimum 18 in-Hg (Figure 4).

