

## Solenoid Regulator Valve Kit

**Part No.**  
**76948-14K**

- Valve
- Spring
- End Plug
- O-Rings (2)

1 Extra

## Bore Sizing Tool

**Part No.**  
**76948-BST2**

**NOTE:** Sonnax bore sizing tool is recommended to fit this valve to a closer tolerance.

## Ford 4R70E, 4R70W, 4R75E, 4R75W, AODE

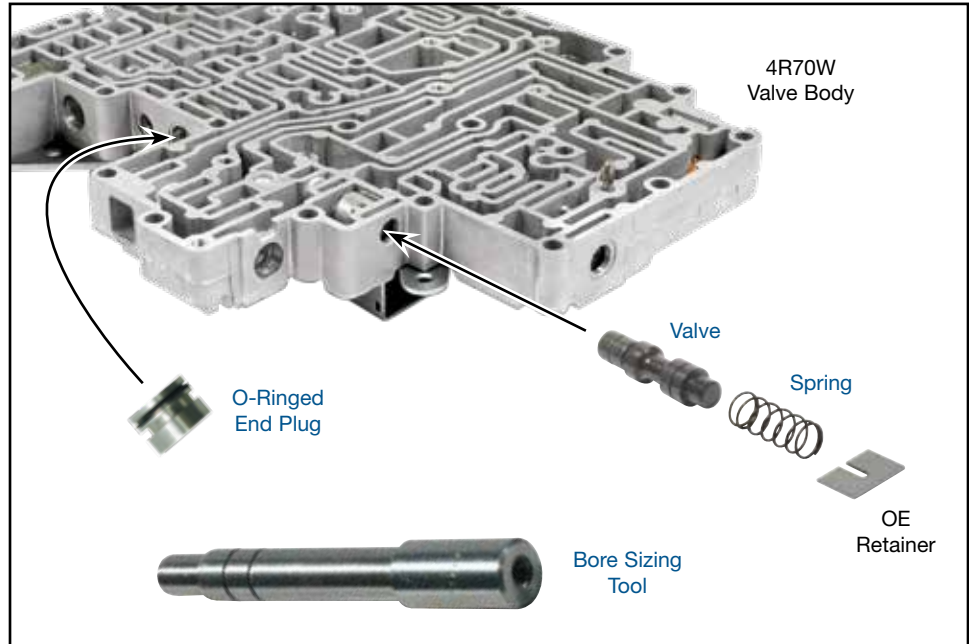

OE Valve

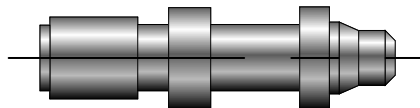

Sonnax Valve

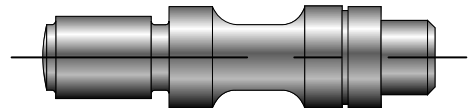

### 1. Solenoid Regulator Valve Bore Wear Test

- With the valve in the idle/rest position, place a small amount of oil into the balance port (**Figure 1**, page 2). Follow with low air pressure. There should be little or no oil/air leakage past the valve spool and out the neighboring exhaust port.
- Block the valve into the regulating position with a screwdriver or .134" diameter pin at the balance port. Make sure valve spool closes the V-notch at the casting port. Place a small amount of oil into the line port and follow with low air pressure. There should be little or no oil/air leakage past the valves spools and out the front exhaust port or SOLP (solenoid pressure) port.
- To check for a sticking valve, remove the clip and spring from the valve body. Pull the valve to the end of its stroke, reinsert, rotate 90 degrees, and then pull outward. Repeat this procedure 2-3 times. A sticking valve will hang up or seize in the bore when rotated and stroked.

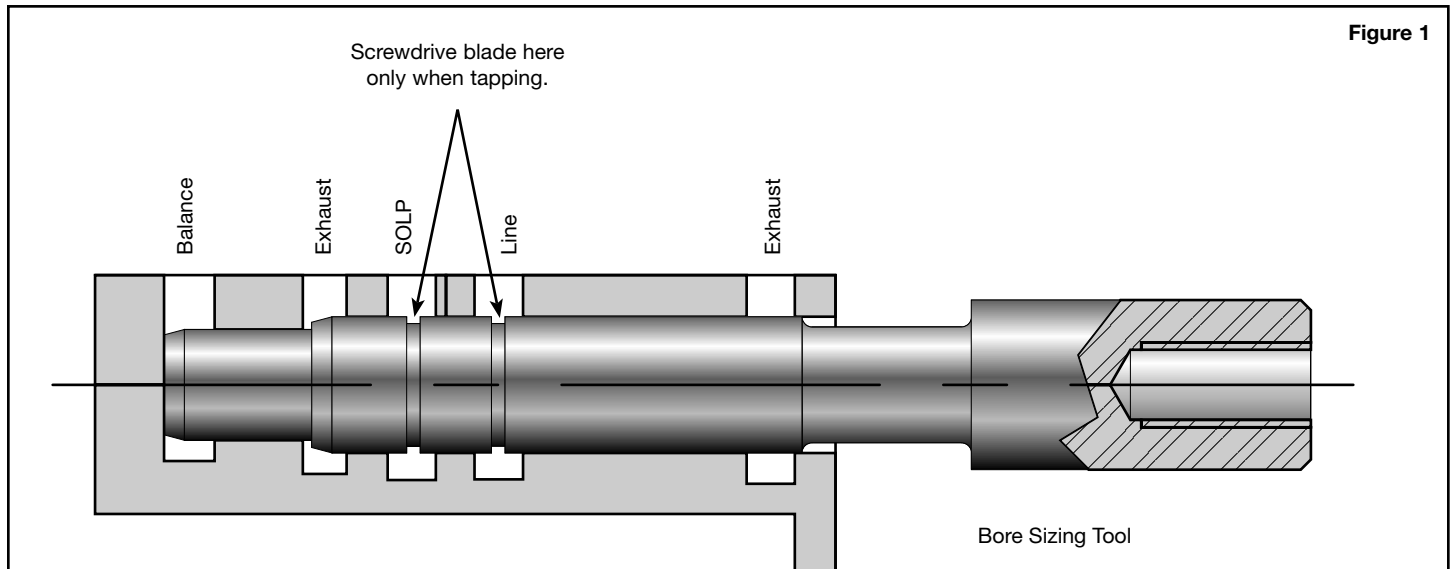

Figure 1

## 2. Bore Sizing Instructions

- Insert the end of Sonnax bore sizing tool 76948-BST2 into the solenoid regulator bore (Figure 1). Press it into bore until it bottoms. A  $\frac{1}{4}$  – 20 UNC tapped hole is provided in the tool to adapt to a puller or slide hammer, if needed.
- Remove bore sizing tool and check to see if Sonnax valve moves freely within the bore.
- If Sonnax valve does not move freely, reinstall Sonnax bore sizing tool and tap the sizing tool up and down using a hammer and screwdriver as shown. This should smooth out any ridges in the bore. Repeat this process until the valve strokes freely.

## 3. Solenoid Regulator Valve Instructions

- Push Sonnax valve into the bore with longer end of spool inboard.
- Place Sonnax spring over the outboard valve stem and compress in the bore with screwdriver.
- Reinstall the OE retainer.
- Stroke the valve several times to verify it moves freely. Resize bore if needed.

## 4. 1-2/2-3 Shift Valve End Plug Installation Instructions

- If valve is not going to be removed, hold/wedge the valve inward with a small flatblade screwdriver to keep the valve in place.
- Remove the original plug from the bore and discard. Save the OE retaining clip.
- Install o-ring into the inner groove of the Sonnax plug. Pre-lube with assembly lube.
- Check for burrs and remove if necessary.
- Rotate the end plug during install and push into bore with tapped hole facing out, just enough to return the retaining clip. The 8–32 UNC tapped hole may be used to assist in plug installation and removal.

## 4. Final Testing

Vacuum testing at the port(s) indicated holds the recommended minimum 18 in-Hg (Figure 2).

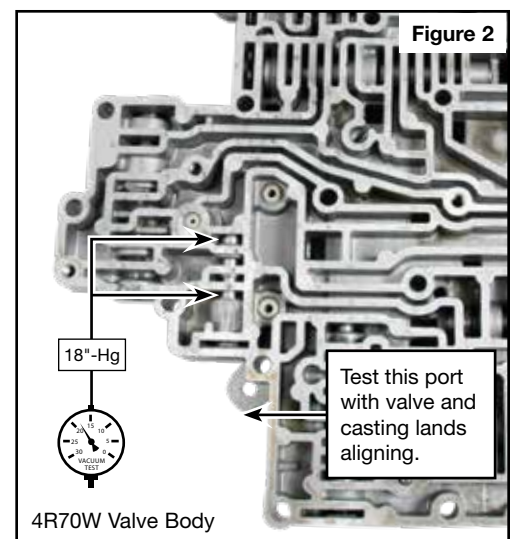

Figure 2