

TCC Regulator & Isolator Valve Kit

Part No.
77754-03K



- Isolator Valve
- Spring
- Regulator Valve
- Regulator Sleeve

Patent Nos. 6,990,996 & 7,104,273

NOTE: 4L60-E '97-earlier only, non-EC3 units.



NOTE: See "Part Selection" on this page and "Reaming Options" on page 2 for usage & tooling requirements.

GM 4L60-E, 4L65-E, 4L70-E

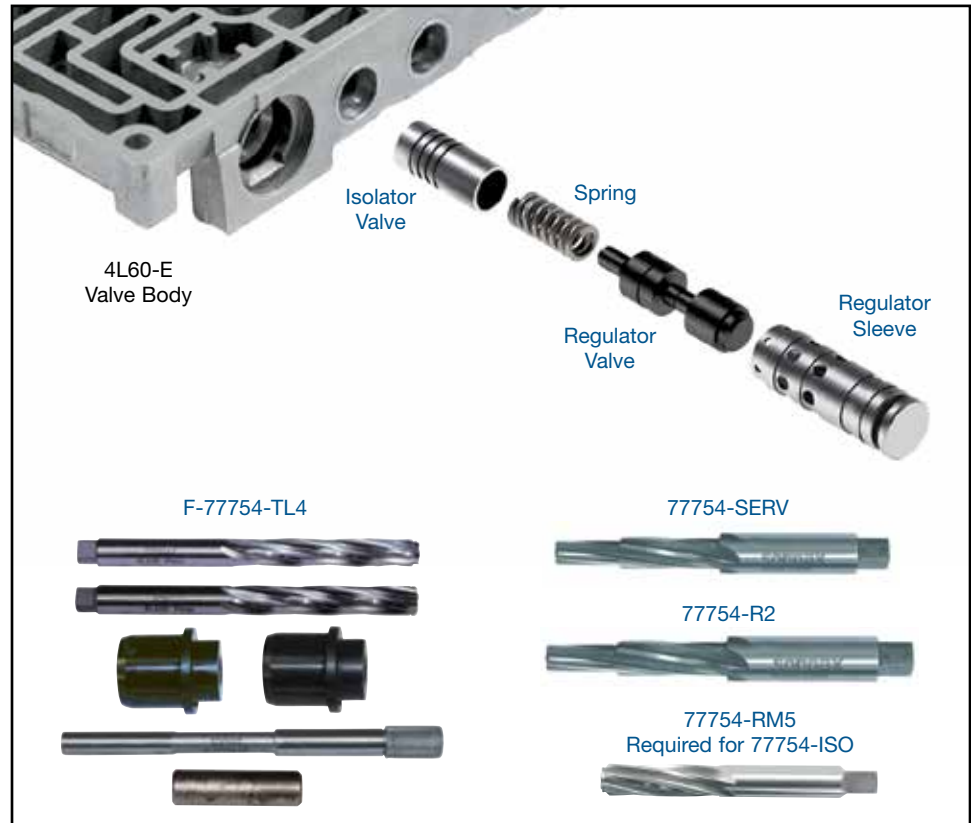

1. Part Selection

a. There are two TCC regulator valve kit options. Selection is based on the application year and TCC apply strategy.

- **77754-04K** matches the OE apply rate. It can be used in any application and is required in '98-later vehicles using EC3 apply strategy.
- **77754-03K** has an increased apply rate and should only be used in '97-earlier vehicles which do not use EC3 apply strategy, though it can be used in PWM applications.

b. Measure OE Isolator Valve Diameter & Evaluate Isolator Section of Bore for Wear

OE Isolator Valve Diameter	Isolator Bore Worn?	Use Reaming Option	Install Sonnax Part Number
.441"	No	Reaming Option A	77754-03K or 77754-04K
.441"	Yes	Reaming Option B	77754-03K or 77754-04K and 77754-ISO
.473"	N/A	Reaming Option C	77754-03K or 77754-04K and 77754-ISO

Tool Kits

Part No.

77754-R2

Reamer For Non-Serviced VB

Part No.

77754-SERV

Reamer For GM-Serviced VB

Part No.

77754-RM5

Reamer Use with 77754-ISO



Part No.

F-77754-TL4

- Reamers (2)
- Reamer Jigs (2)
- Guide Pin
- Stop Pin

NOTE: Sonnax "F-Tool" kits designed to service a specific bore require the **VB-FIX**, a self-aligning valve body reaming fixture. More information and instructions can be found online at www.sonnax.com.

2. Reaming Options

a. Isolator valve was .441" dia. and isolator bore is not worn:

- Bench Tool Option – use **77754-R2**
- F-Tool Option – use **F-77754-TL4** and **VB-FIX**

b. Isolator valve was .441" dia. but isolator bore is worn:

- Bench Tool Option – use **77754-R2** followed by **77754-RM5**
- F-Tool Option – use **F-77754-TL4** and **VB-FIX**

c. Isolator valve was .473" dia. – GM Service valve body (Figure 1):

- Bench Tool Option – use **77754-SERV** followed by **77754-RM5**
- F-Tool Option – use **F-77754-SERV** followed by **F-77754-TL4**, each using **VB-FIX**



NOTE: Tool kit **F-77754-SERV** is no longer in production but may be available from distributor inventory.

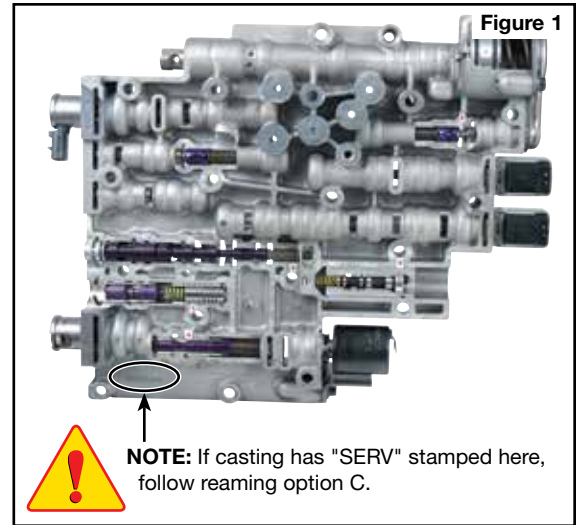

3. Disassembly

Remove and discard OE valve train. Save OE retainer for reuse.

4. Reaming Instructions



NOTE: The following reaming instructions are for bench tool reaming only (see reaming options A, B or C above). Reaming directions for F-tool kits that utilize the VB-FIX can be found on those individual tool kit instructions.

CAUTIONS & SUGGESTIONS:

- Turning the reamer backward will dull it prematurely.
- Pushing on the reamer will result in poor surface finish and inadequate and sporadic material removal.
- Never use a crescent wrench, ratchet or pliers to turn the reamer.
- A dull reamer will cut a smaller hole. Reamers can be sharpened, but should only be done by a professional tool sharpener. Actual life of a Sonnax reamer before resharpening or replacing averages 50-70 bores.
 - a. Clean bore thoroughly in a solvent tank.
 - b. Generously lubricate the bore and reamer with cutting fluid (i.e. Mobilmet S-122, Lubegard® Bio-Tap, Tap Magic™, etc.). For best results, provide a continuous flow of cutting fluid during the reaming process.
 - c. Gently insert the proper reamer into the bore until the cutting tip contacts the first land to be reamed. For Bench Tool options A or B, use **77754-R2** for this step. For Bench Tool option C, use **77754-SERV** for this step.
 - d. Use a loose-fitting reamer socket and a wobble adapter to ream the bore. The reamer can be turned by using a speed handle or with a low-RPM, high-torque drill regulated to a maximum of 200 RPM. The reaming actions must be clockwise in smooth and continuous motion at 60-200 RPM. Continue reaming until the reamer stop is reached.

4. Reaming Instructions (continued)

- e. Using low air pressure, blow the chips free before removing reamer.
- f. To remove the reamer, turn clockwise while slowly pulling outward.
- g. If performing bench reaming option A, proceed to step 5, "Installation & Assembly". If performing bench reaming option B or C, repeat steps "a" through "f" with reamer 77754-RM5.

5. Installation & Assembly

- a. Ensure valve bore and body is clean and cleared of dirt and debris.
- b. Refer to **Figures 2** and **3** for correct Sonnax valve train installation lineup. Consult **Figures 4, 5** and **6** to determine whether your original lineup was PWM or non-PWM.
- c. **For PWM applications:** Install Sonnax valve lineup as pictured in **Figure 2**. Use transjel to retain spring in the isolator valve during installation.
- For non-PWM applications:** Install Sonnax valve lineup as pictured in **Figure 3**.
- d. Insert valve/sleeve assembly into the valve body, just deep enough to reinstall OE retaining clip around sleeve.

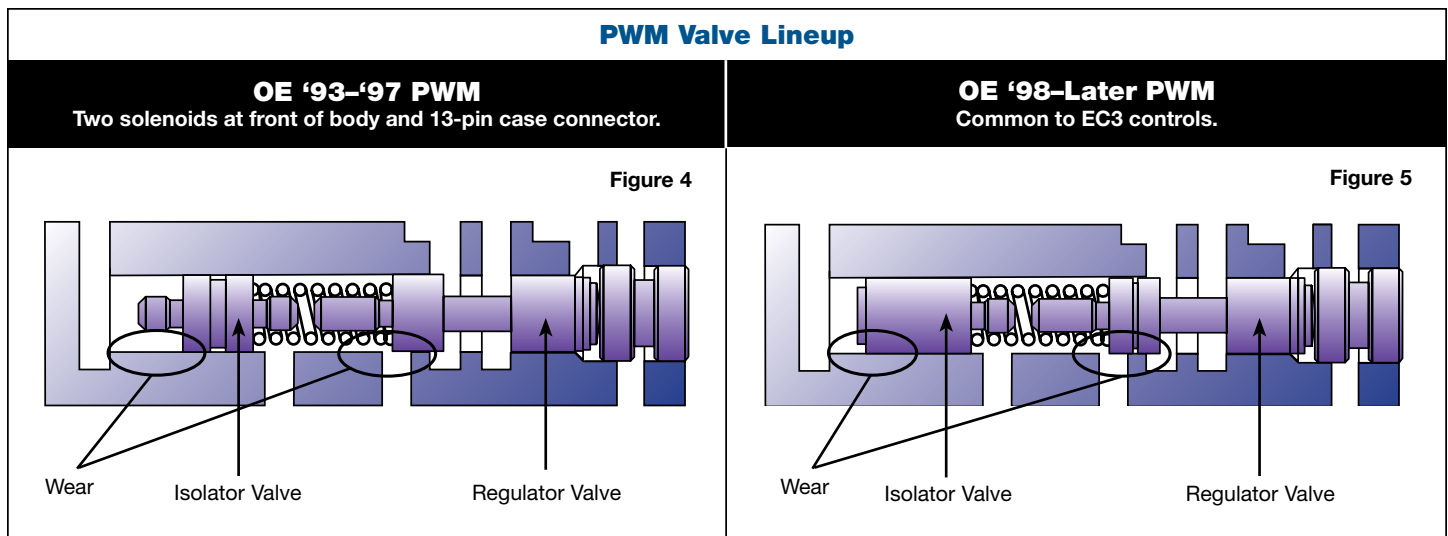
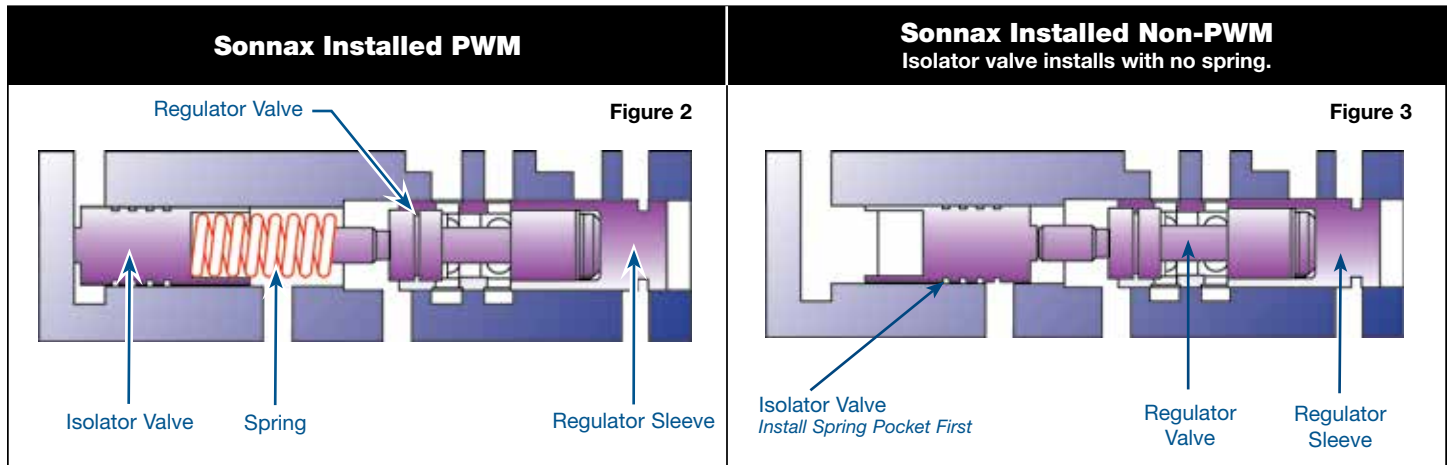

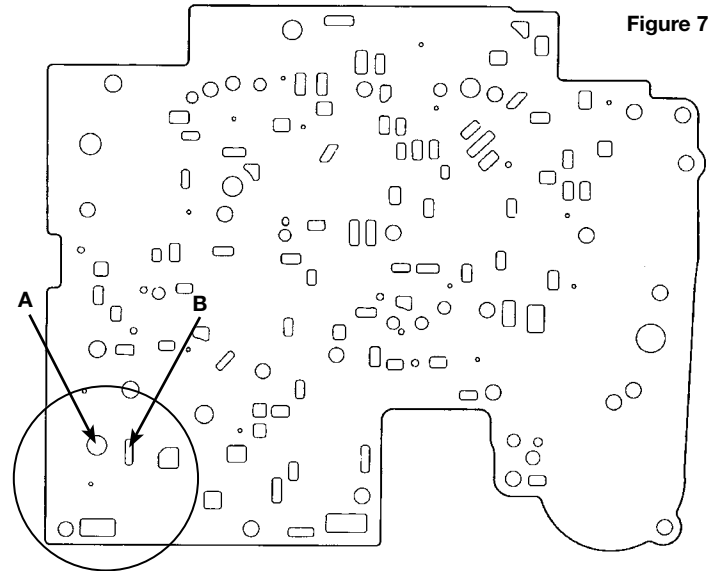
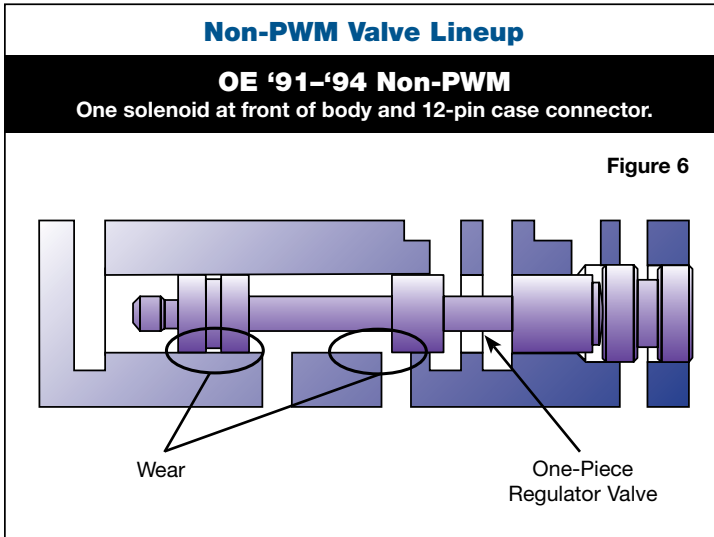

NOTE: Since the castings for PWM and non-PWM valve bodies are identical, this kit can be used when updating a non-PWM valve body for use in a PWM unit or retrofitting a PWM valve body for use in a non-PWM unit. The separator plate must also be changed when this is done (Figure 7).

PWM plates have "A" & "B" holes (Figure 7).

Non-PWM plates do not have holes "A" & "B" (Figure 7).

TCC Regulator & Isolator Valve Kit

Part No.
77754-04K



- Isolator Valve
- Spring
- Regulator Valve
- Regulator Sleeve

Patent Nos. 6,990,996 & 7,104,273

NOTE: Use in any application including '98-Later EC3 units. Compatible with all PWM and non-PWM 4L60-E units.



NOTE: See "Part Selection" on this page and "Reaming Options" on page 2 for usage & tooling requirements.

GM 4L60-E, 4L65-E, 4L70-E

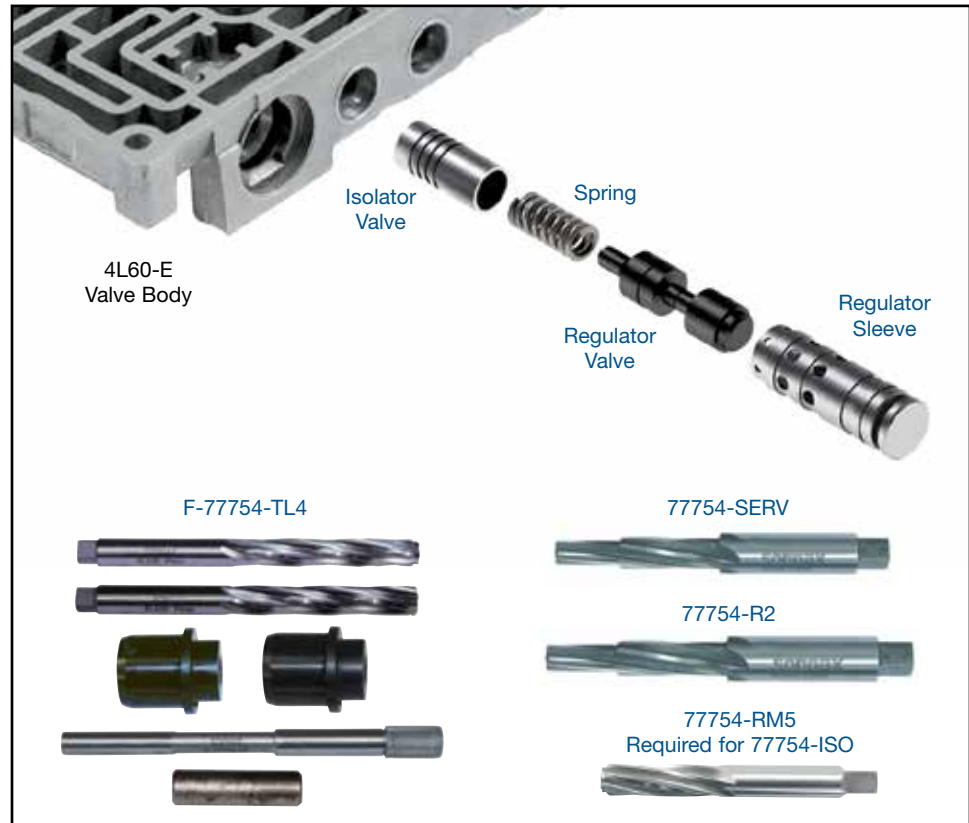

1. Part Selection

a. There are two TCC regulator valve kit options. Selection is based on the application year and TCC apply strategy.

- **77754-04K** matches the OE apply rate. It can be used in any application and is required in '98-later vehicles using EC3 apply strategy.
- **77754-03K** has an increased apply rate and should only be used in '97-earlier vehicles which do not use EC3 apply strategy, though it can be used in PWM applications.

b. Measure OE Isolator Valve Diameter & Evaluate Isolator Section of Bore for Wear.

OE Isolator Valve Diameter	Isolator Bore Worn?	Use Reaming Option	Install Sonnax Part Number
.441"	No	Reaming Option A	77754-03K or 77754-04K
.441"	Yes	Reaming Option B	77754-03K or 77754-04K and 77754-ISO
.473"	N/A	Reaming Option C	77754-03K or 77754-04K and 77754-ISO

Tool Kits

Part No.

77754-R2

- Reamer For Non-Serviced VB

Part No.

77754-SERV

- Reamer For GM-Serviced VB

Part No.

77754-RM5

- Reamer Use with 77754-ISO



Part No.

F-77754-TL4

- Reamers (2)
- Reamer Jigs (2)
- Guide Pin
- Stop Pin

NOTE: Sonnax "F-Tool" kits designed to service a specific bore require the **VB-FIX**, a self-aligning valve body reaming fixture. More information and instructions can be found online at www.sonnax.com.

2. Reaming Options

a. Isolator valve was .441" dia. and isolator bore is not worn:

- Bench Tool Option – use **77754-R2**
- F-Tool Option – use **F-77754-TL4** and **VB-FIX**

b. Isolator valve was .441" dia. but isolator bore is worn:

- Bench Tool Option – use **77754-R2** followed by **77754-RM5**
- F-Tool Option – use **F-77754-TL4** and **VB-FIX**

c. Isolator valve was .473" dia.

– GM Service valve body (Figure 1):

- Bench Tool Option – use **77754-SERV** followed by **77754-RM5**
- F-Tool Option – use **F-77754-SERV** followed by **F-77754-TL4**, each using **VB-FIX**



NOTE: Tool kit **F-77754-SERV** is no longer in production but may be available from distributor inventory.

3. Disassembly

Remove and discard OE valve train. Save OE retainer for reuse.

4. Reaming Instructions



NOTE: The following reaming instructions are for bench tool reaming only (see reaming options A, B or C above). Reaming directions for F-tool kits that utilize the **VB-FIX** can be found on those individual tool kit instructions.

CAUTIONS & SUGGESTIONS:

- Turning the reamer backward will dull it prematurely.
- Pushing on the reamer will result in poor surface finish and inadequate and sporadic material removal.
- Never use a crescent wrench, ratchet or pliers to turn the reamer.
- A dull reamer will cut a smaller hole. Reamers can be sharpened, but should only be done by a professional tool sharpener. Actual life of a Sonnax reamer before resharpening or replacing averages 50-70 bores.

a. Clean bore thoroughly in a solvent tank.

b. Generously lubricate the bore and reamer with cutting fluid (i.e. Mobilmet S-122, Lubegard® Bio-Tap, Tap Magic™, etc.). For best results, provide a continuous flow of cutting fluid during the reaming process.

c. Gently insert the proper reamer into the bore until the cutting tip contacts the first land to be reamed. For Bench Tool options A or B, use **77754-R2** for this step. For Bench Tool option C, use **77754-SERV** for this step.

d. Use a loose-fitting reamer socket and a wobble adapter to ream the bore. The reamer can be turned by using a speed handle or with a low-RPM, high-torque drill regulated to a maximum of 200 RPM. The reaming actions must be clockwise in smooth and continuous motion at 60-200 RPM. Continue reaming until the reamer stop is reached.

Figure 1

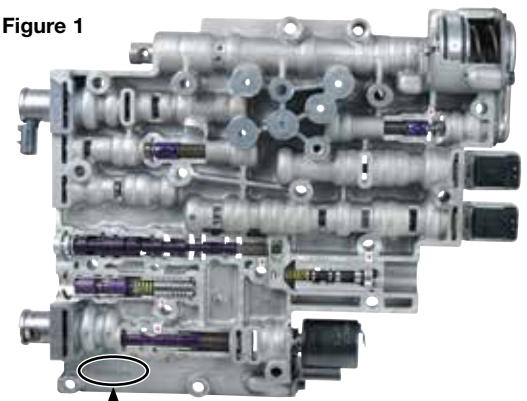

NOTE: If casting has "SERV" stamped here, follow reaming option C.

4. Reaming Instructions (continued)

- e. Using low air pressure, blow the chips free before removing reamer.
- f. To remove the reamer, turn clockwise while slowly pulling outward.
- g. If performing bench reaming option A, proceed to step 5, "Installation & Assembly". If performing bench reaming option B or C, repeat steps "a" through "f" with reamer 77754-RM5.

5. Installation & Assembly

- a. Ensure valve bore and body is clean and cleared of dirt and debris.
- b. Refer to **Figures 2** and **3** for correct Sonnax valve train installation lineup. Consult **Figures 4, 5** and **6** to determine whether your original lineup was PWM or non-PWM.
- c. **For PWM applications:** Install Sonnax valve lineup as pictured in **Figure 2**. Use Transjel to retain spring in the isolator valve during installation.

For non-PWM applications: Install Sonnax valve lineup as pictured in **Figure 3**.

- d. Insert valve/sleeve assembly into the valve body, just deep enough to reinstall OE retaining clip around sleeve.

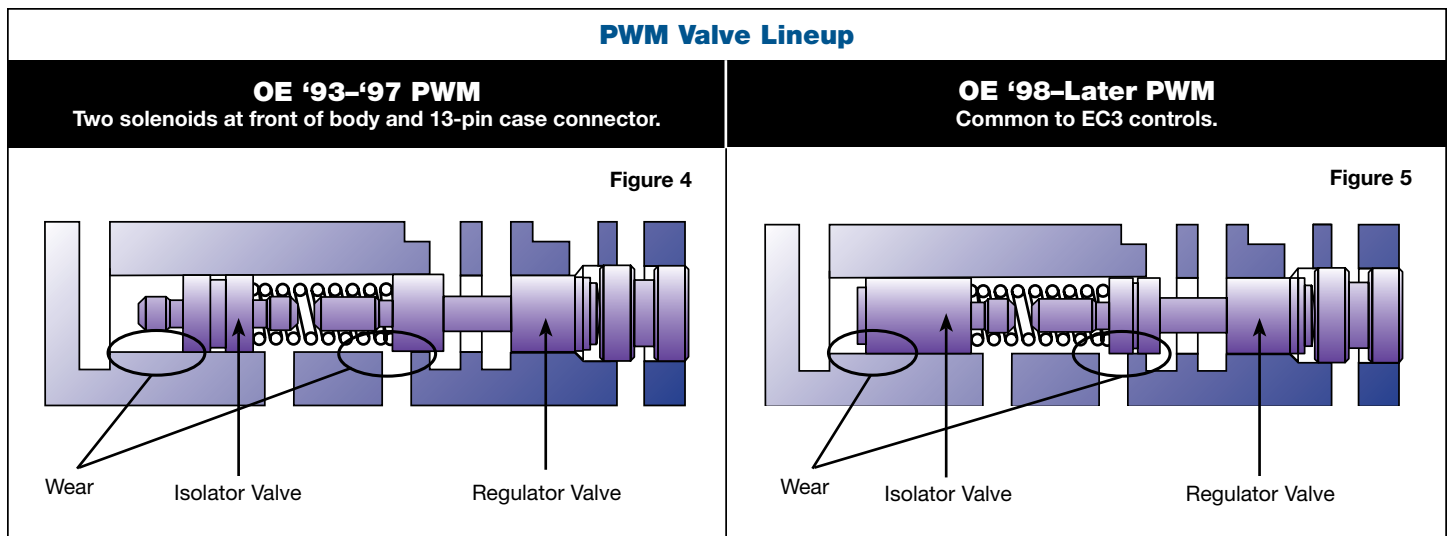
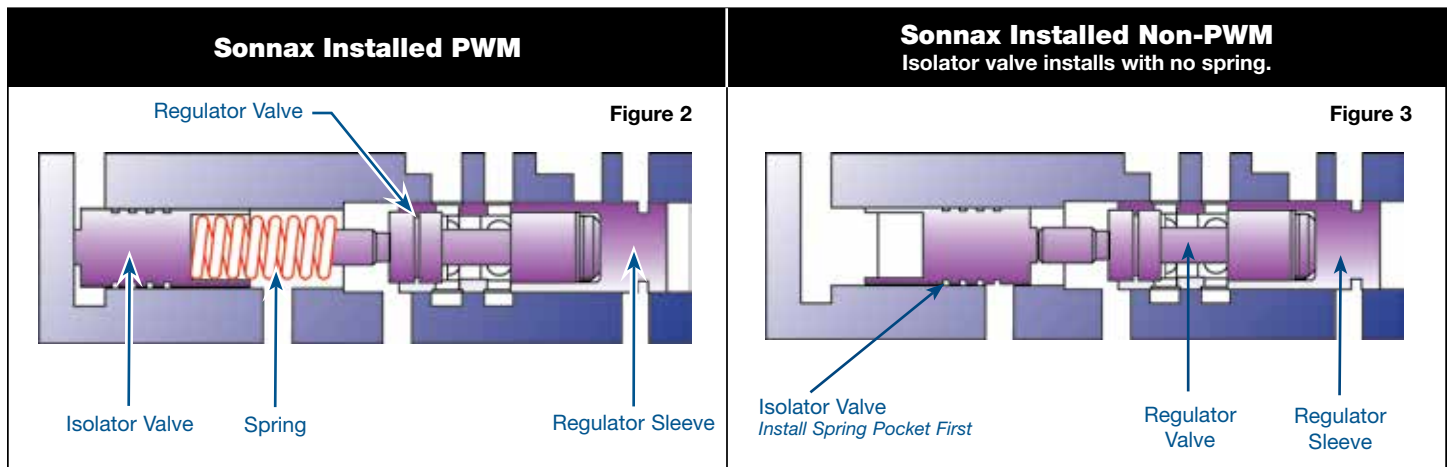

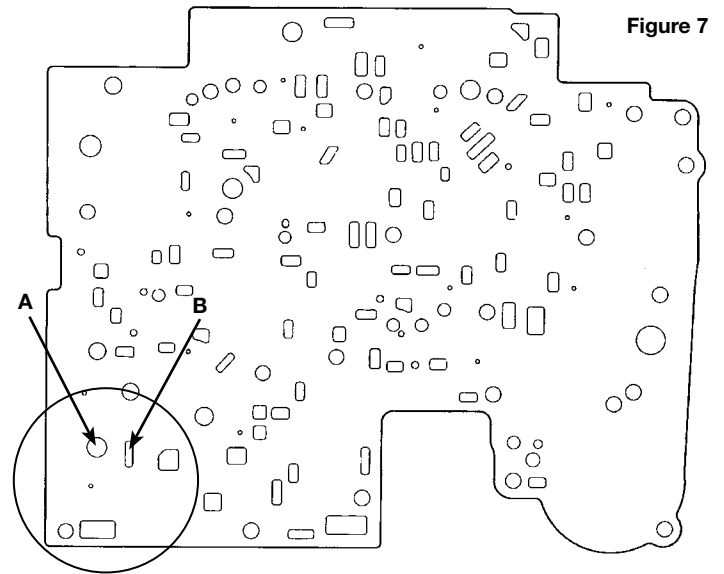
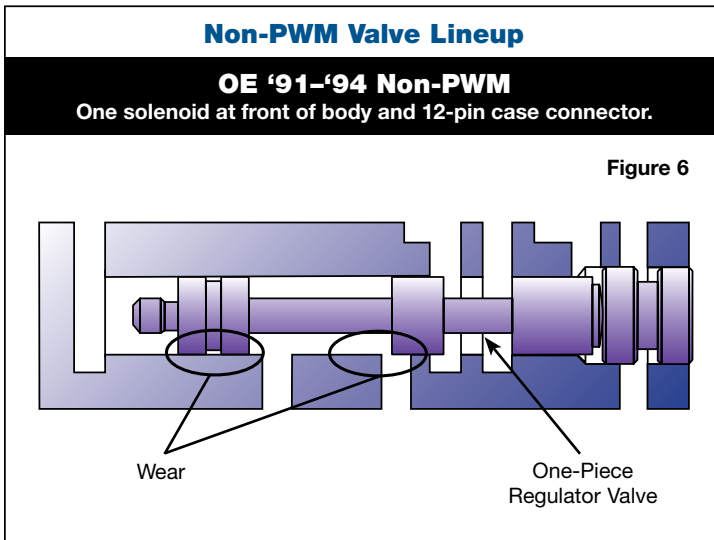

NOTE: Since the castings for PWM and non-PWM valve bodies are identical, this kit can be used when updating a non-PWM valve body for use in a PWM unit or retrofitting a PWM valve body for use in a non-PWM unit. The separator plate must also be changed when this is done (Figure 7).

PWM plates have "A" & "B" holes (Figure 7).

Non-PWM plates do not have holes "A" & "B" (Figure 7).

Isolator Sleeve Kit

Part No.

77754-ISO

- Isolator Sleeve
- Retaining Clip

Patent Nos. 6,990,996 & 7,104,273

NOTE: This kit can ONLY be used with Sonnax TCC regulator and isolator valve kit **77754-03K** or **77754-04K**. This sleeve will NOT work with the OE isolator valve.

MUST READ: "Part Selection" and "Reaming Options" on pages 1 & 2 for usage & tooling requirements.



GM 4L60-E, 4L65-E, 4L70-E

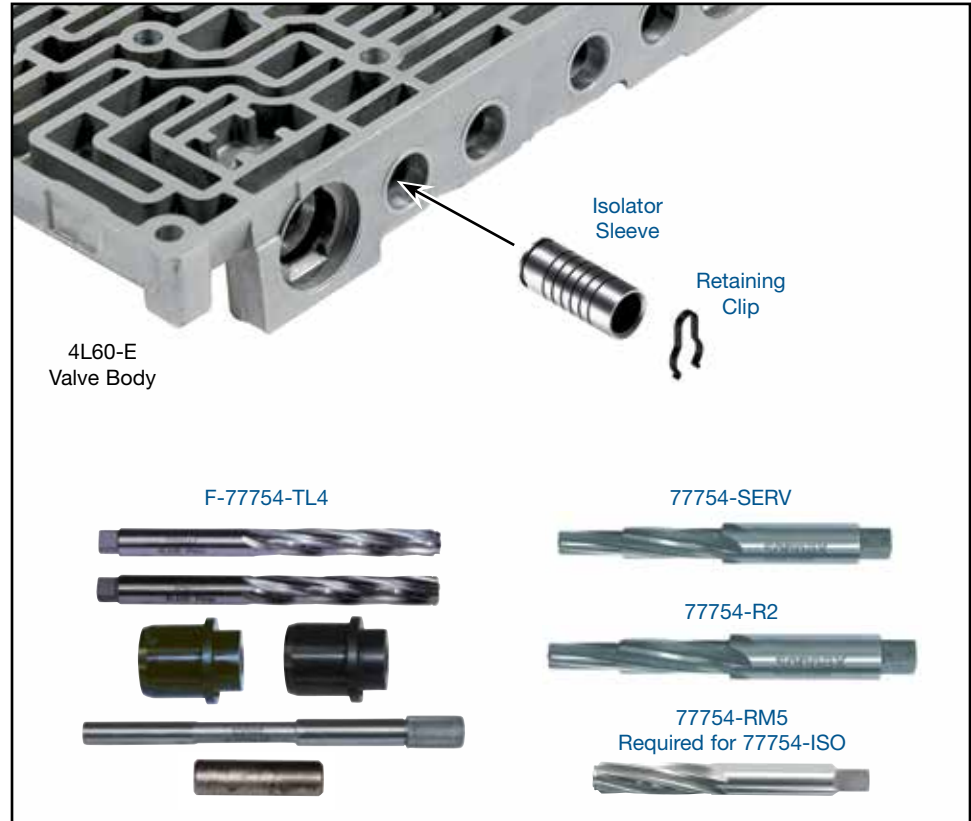

1. Part Selection

a. There are two TCC regulator valve kit options. Selection is based on the application year and TCC apply strategy.

- 77754-04K matches the OE apply rate. It can be used in any application and is required in '98-later vehicles using EC3 apply strategy.
- 77754-03K has an increased apply rate and should only be used in '97-earlier vehicles which do not use EC3 apply strategy, though it can be used in PWM applications.

b. Measure OE Isolator Valve Diameter & Evaluate Isolator Section of Bore for Wear.

OE Isolator Valve Diameter	Isolator Bore Worn?	Use Reaming Option	Install Sonnax Part Number
.441"	No	Reaming Option A	77754-03K or 77754-04K
.441"	Yes	Reaming Option B	77754-03K or 77754-04K and 77754-ISO
.473"	N/A	Reaming Option C	77754-03K or 77754-04K and 77754-ISO

Tool Kits

Part No.

77754-R2

Reamer For Non-Serviced VB

Part No.

77754-SERV

Reamer For GM-Serviced VB

Part No.

77754-RM5

Reamer Use with 77754-ISO

Part No.

F-77754-TL4

- Reamers (2)
- Reamer Jigs (2)
- Guide Pin
- Stop Pin



Part No.

F-77754-SERV

Reamer For GM-Serviced VB

NOTE: Sonnax "F-Tool" kits designed to service a specific bore require the VB-FIX, a self-aligning valve body reaming fixture. More information and instructions can be found online at www.sonnax.com.



2. Reaming Options

a. Isolator valve was .441" dia. and isolator bore is not worn:

- Bench Tool option – use 77754-R2
- F-tool option – use F-77754-TL4 and VB-FIX

b. Isolator valve was .441" dia. but isolator bore is worn:

- Bench Tool option – use 77754-R2 followed by 77754-RM5
- F-tool option – use F-77754-TL4 and VB-FIX

c. Isolator valve was .473" dia. – GM Service valve body (Figure 1):

- Bench Tool option – use 77754-SERV followed by 77754-RM5
- F-tool option – use F-77754-SERV followed by F-77754-TL4, each using VB-FIX



NOTE: Tool kit F-77754-SERV is no longer in production but may be available from distributor inventory.

3. Disassembly

Remove and discard OE valve train. Save OE retainer for reuse.

4. Reaming Instructions



NOTE: In order to install 77754-ISO two reaming operations will need to be completed. First, depending on existing valve measurement (see page 1), follow either Reaming **Option B** or Reaming **Option C**, beginning with 77754-R2 or 77754-SERV. Second, complete the reaming process for either option using 77754-RM5 to ream the inboard section of the isolator bore. Follow the guidelines below for either bench reaming process. See individual tool kit instructions for options using F-style reaming tools.

CAUTIONS & SUGGESTIONS:

- Turning the reamer backward will dull it prematurely.
- Pushing on the reamer will result in poor surface finish and inadequate and sporadic material removal.
- Never use a crescent wrench, ratchet or pliers to turn the reamer.
- A dull reamer will cut a smaller hole. Reamers can be sharpened, but should only be done by a professional tool sharpener. Actual life of a Sonnax reamer before resharpening or replacing averages 50-70 bores.
 - a. Clean bore thoroughly in a solvent tank.
 - b. Generously lubricate the bore and reamer with cutting fluid (i.e. Mobilmet S-122, Lubegard® Bio-Tap, Tap Magic™, etc.). For best results, provide a continuous flow of cutting fluid during the reaming process.
 - c. Gently insert the proper reamer into the bore until the cutting tip contacts the first land to be reamed.
 - d. Use a loose-fitting reamer socket and a wobble adapter to ream the bore. The reamer can be turned by using a speed handle or with a low-RPM, high-torque drill regulated to a maximum of 200 RPM. The reaming actions must be clockwise in smooth and continuous motion at 60-200 RPM. Continue reaming until the reamer stop is reached.

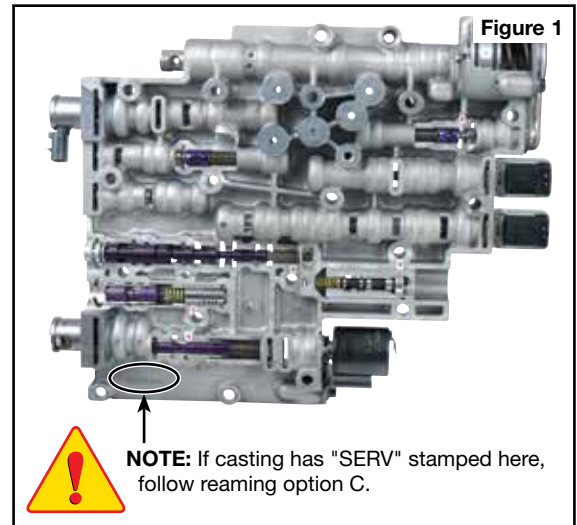

Figure 1

NOTE: If casting has "SERV" stamped here, follow reaming option C.

4. Reaming Instructions (continued)

- e. Using low air pressure, blow the chips free before removing reamer.
- f. To remove reamer, turn clockwise while slowly pulling outward.
- g. Repeat steps "a" through "f" with reamer 77754-RM5.

5. Installation & Assembly

- a. Ensure valve bore and body is clean and cleared of dirt and debris.
- b. Install Sonnax isolator sleeve. The end of the sleeve with 4 cross-slots and retaining clip groove is installed inboard.
- c. Push sleeve into the bore until it bottoms out, then install the retaining clip into the largest groove on the sleeve.



NOTE - Retaining Clip Modification: Due to limited clearance between the isolator sleeve and valve body, it may be necessary to modify the retaining clip for proper installation. If the clip does not fit around the installed sleeve, grind one foot of the clip off on a bench grinder (**Figure 2**).

- d. Install Sonnax TCC regulator and isolator valve kit 77754-03K or 77754-04K following the instructions included in those kits.

