

Pressure Reducing Valve Kit

Part No.
84741-10K

- Sleeve
- Valve
- Spring
- Retaining Clip



Tool Kit

Part No.
F-84741-TL10

- Reamers (2)
- Reamer Jig
- Guide Pin



NOTE: Sonnax “F-Tool” kits designed to service a specific bore require the VB-FIX, a self-aligning valve body reaming fixture. More information and instructions can be found online at www.sonnax.com.

Hyundai/Kia A4CF1, A4CF2

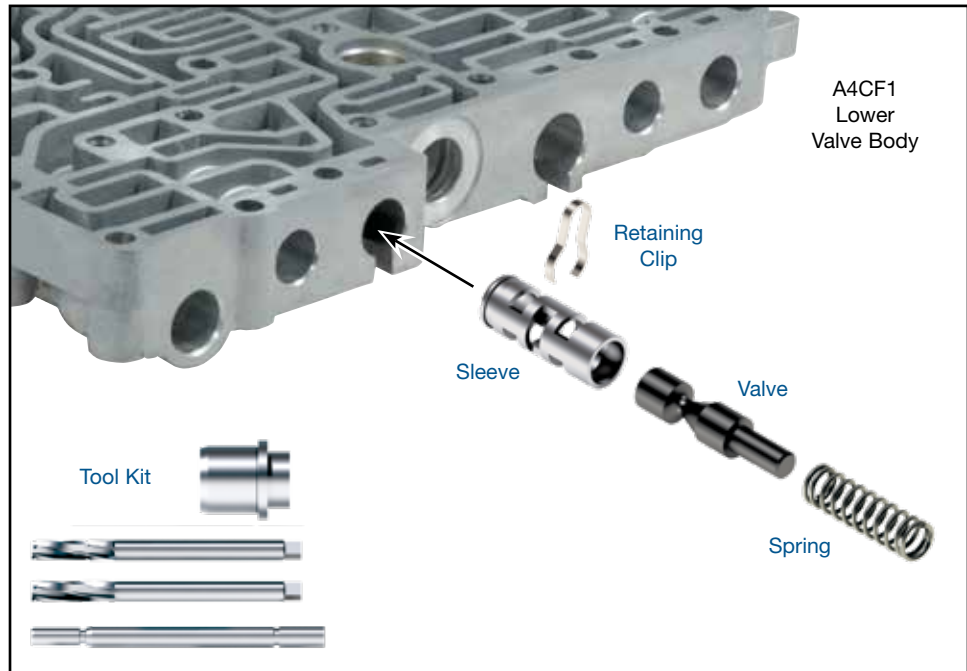

NOTE: Keep OE setting of the adjuster plug to maintain OE solenoid feed pressure. Turning the adjusting nut clockwise will reduce the gap setting, lowering solenoid pressure. Turning the adjusting nut counter-clockwise will increase the gap setting, increasing solenoid feed pressure

1. Disassembly

Remove and discard OE valve and spring, while keeping retaining clip and end plug for reuse.

2. Bore Reaming

Ream pressure reducing bore (for reaming instructions/reamer care, please visit www.sonnax.com). Sonnax reaming tool kit **F-84741-TL10** and **VB-FIX** are required for this operation.

3. Installation & Assembly

- Ensure all debris has been removed from the valve bore and valve body.
- Install Sonnax sleeve and valve into the bore with the grooved end of the sleeve inboard and valve spring stem facing outboard.
- Rotate the sleeve so the circuit ports are facing upward, toward the separator plate.
- Install Sonnax retaining clip in the sleeve groove, accessed through the balance port.
- Install Sonnax spring.
- Reinstall the OE adjustable end plug and retaining pin.

4. Final Testing

Vacuum testing at the port(s) indicated holds the recommended minimum 18 in-Hg.

