

Oversized TCC Apply Valve Kit



Part No.
84754-16K

- Valve
- Seal PTFE
- Spring

NOTE: '96-Earlier with steel valve.

Patent No. 6,832,671

Tool Kit



Part No.
84754-TL5

- Reamer Jig '96-Earlier, 9/16"
- Reamer Jig '97-Later, 5/8"
- Reamer

NOTE: Required tool kit **84754-TL5** is no longer in production. Check with your distributor for availability.

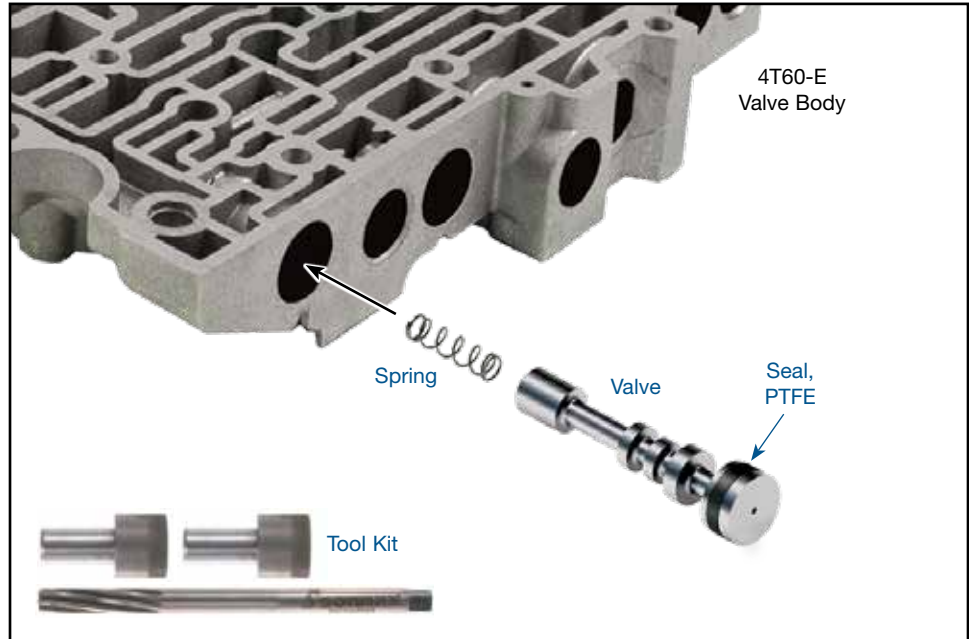

1. Disassembly

Remove valve from TCC apply bore and clean valve body.

2. Bore Reaming

Sonnax reaming tool kit **84754-TL5** is required for this operation.

- Clamp valve body horizontally to bench with open circuits up.
- Fill bore with proper cutting fluid (Tap Magic®).
- Insert proper year-related Sonnax reamer jig into bore (**Figure 1**).



NOTE: The '96-earlier applications use the 9/16" dia. reamer jig; and the '97-later applications use the 5/8" dia. reamer jig (**Figure 1**).

- Soak the fluted end of reamer with cutting fluid.
- Insert reamer into reamer jig until guide nub enters the first bore to be cut (**Figure 2**).
- With the reamer carefully and securely positioned, use a speed handle to ream the bore. The reaming action should be clockwise in a smooth and continuous motion at approximately 1 to 1½ revolutions per second. The reamer should actually pull itself through the bore, so little or no back pressure should be applied to the reamer or speed handle. Continue reaming until the tip of the reamer bottoms in the bore. Spin the reamer 5 to 10 more times after bore bottoming to allow for excess material removal and better surface finish.

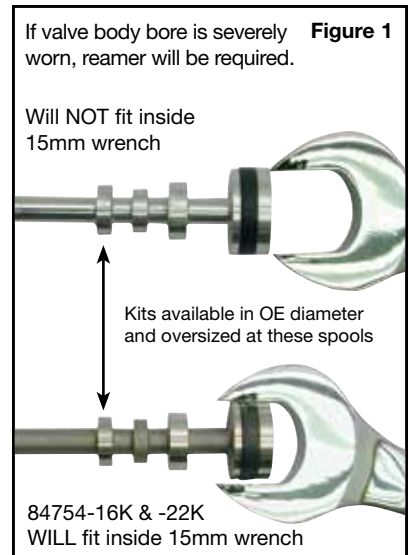

2. Bore Reaming (continued)

- g. Using low air pressure, blow the chips free before removing the reamer. To remove the reamer, turn clockwise while slowly pulling outward on the reamer.
- h. Remove any remaining debris from the bore with low air pressure and cleaning solvent.

3. Installation & Assembly

- a. Be certain all debris has been removed from the valve bore and valve body.
- b. Lubricate casting bore and Sonnax valve.
- c. Using gel, secure the Sonnax seal into the valve groove.
- d. Insert OE spring into the pocket at the end of Sonnax valve.
- e. Insert the spring/valve combo while carefully guiding the seal through the TCC signal passage to prevent damage.
- f. After installation, manually stroke the valve fully a number of times to ensure there are no hang-ups.



NOTE: Some OE applications do not have the inboard valve return spring. In these applications, line pressure is the force holding the valve into TCC off position. The addition of the return spring requires more signal oil pressure, and ensures that a restricted solenoid or large feed signal filter/orifice does not force the valve into apply (**A** in Figure 3).

4. Final Testing

Vacuum testing at the port(s) indicated holds the recommended minimum 18 in-Hg (Figure 4).

