

Overdrive Clutch Hub Bushing

Part No.

92004-L

- Bushings (5)



Note: Fits late-style hubs with shaft O.D. of 1.162" AND housing bore of .937". (Figure 1).

Bushing Specifications:

Inner Dia.: .837"
Width: 1.141"

Chrysler 40TE, 40TES, 41AE, 41TE, 41TES, 42LE, 42RLE

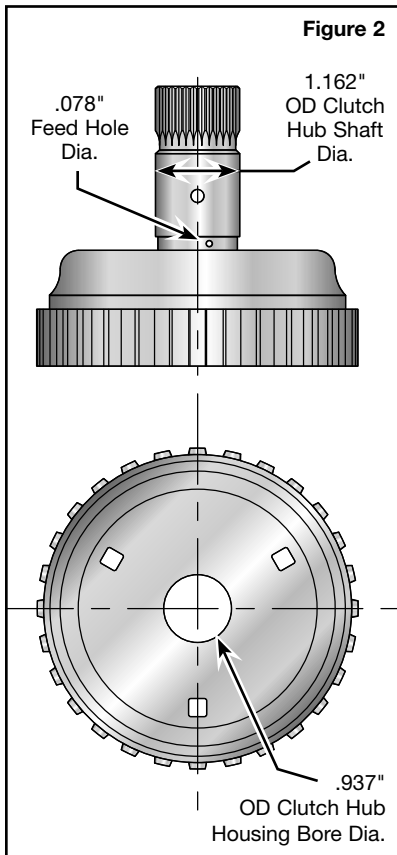
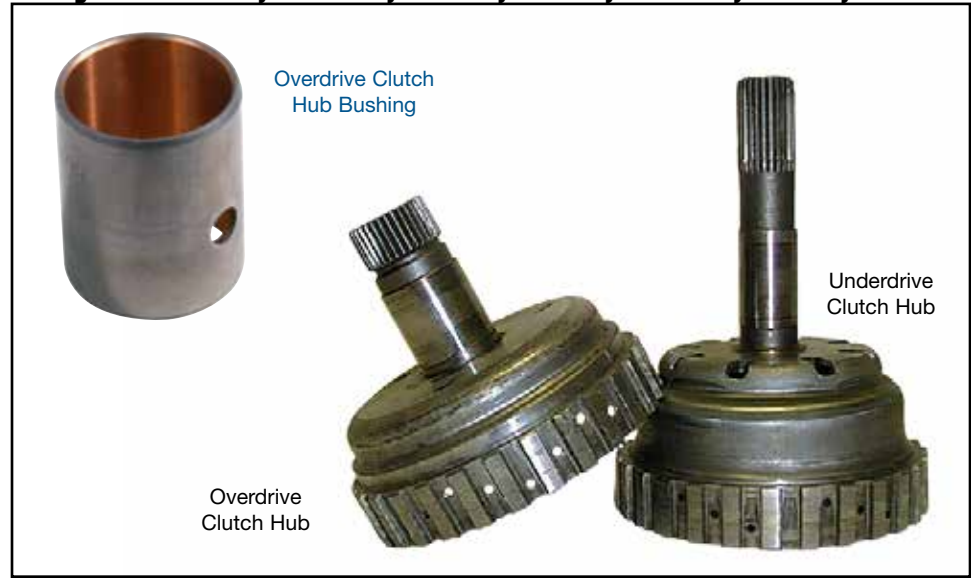

WARNING: Sonnax bushing is designed to work with OE hubs or aftermarket hubs that match OE dimensions. Some aftermarket hubs do not fully meet OE dimensional specifications and may cause fitment issues.

Bushing Application Chart

Figure 1

Sonnax Bushing	Application Years	OD Clutch Hub Housing Bore Dia.	OD Clutch Hub Shaft Dia.	Feed Hole Dia
92004-L	'95-Later	.937"	1.162"	.078"
92004-LOS	'95-Later	.941"	1.162"	.078"

1. Remove both OE bushings from inside diameter of overdrive clutch hub shaft.
2. Verify correct part number application (Figures 1 & 2).
3. Sonnax one-piece bushing features an offset lubrication feed hole. Ensure bushing is oriented correctly and feed hole is aligned with shaft feed hole, then press bushing in using arbor press.



WARNING: Do not use a driver and hammer or a hydraulic press to install bushing, as this may cause distortion and result in fitment problems.