



Toyota/Lexus A340E, A340F '00-Later, V6 & V8 ZIP KIT®

PART NUMBER **A340-LATE-ZIP**

QUICK GUIDE

Parts are labeled here in order of installation. See other side of sheet for details on kit contents.

INSTALLATION DIAGRAM

NOTE: Type 4 EPC-style valve body is shown. Parts will fit in the same locations in a throttle cable-style and Type 3 EPC-style valve body except where noted.

Upper Valve Body
Type 4 Shown

*Not used on Type 3 valve bodies.

! These checkballs may or may not belong!

CAUTION! Note the location of OE checkballs during disassembly! Usage of checkballs vary greatly!

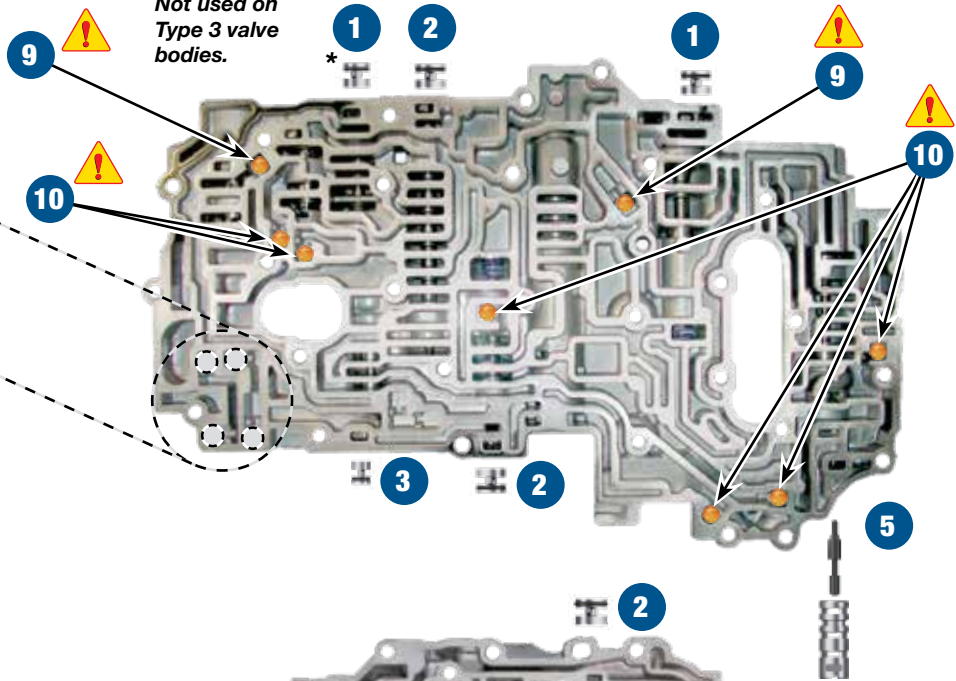

6 CAUTION: If replacing an OE sleeve with **NO** dot or **three** dots, use Sonnax EPC valve with flat on **large** spool diameter.



If replacing an OE sleeve with **two** dots, use Sonnax EPC valve with flat on **small** spool diameter.



Discard the Sonnax EPC valve that is not used.

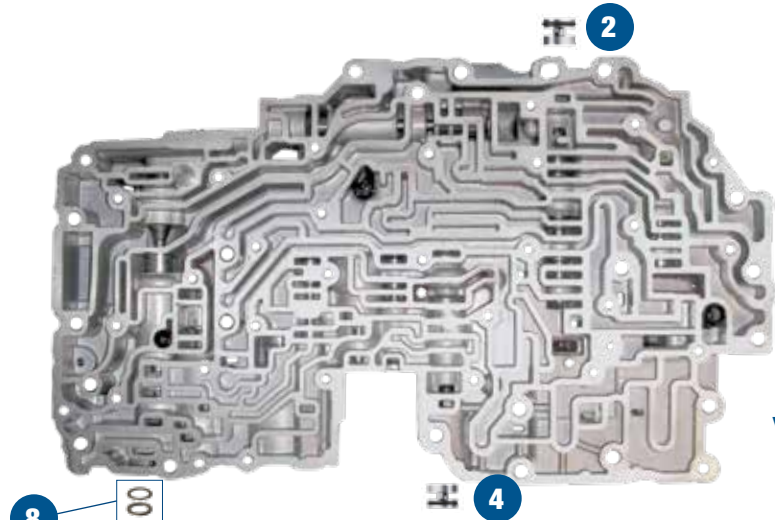

Lower Valve Body
Type 4 Shown

- ! **6 8**
- If replacing an OE sleeve with two or three dots, do **NOT** add shims.
- If replacing an OE sleeve with no dots, add shims.



NOTE: Detailed instructions are included on page 8 of installation and testing booklet.

In addition to general rebuilding tips and technical information, the technical booklet included in this kit contains vacuum testing and additional repair options for higher mileage units or for repairing specific complaints which are beyond the scope of this kit.

Kit Contents & Installation Steps

Step 1 Replace OE End Plugs Secondary Regulator Valve, Reverse Control Valve* **(Type 4 Valve Body Only)*

Packaging Pocket 1

- End Plugs, Large (2)
- O-Rings (4) 2 Extra

Step 2 Replace OE End Plugs 1-2, 2-3 & 3-4 Shift Valves

Packaging Pocket 2

- End Plugs, Medium (3)
- O-Rings (5) 2 Extra

Step 3 Replace OE End Plug 2nd Coast Modulator Valve

Packaging Pocket 3

- End Plug, Small
- O-Rings (2) 1 Extra

Step 4 Replace OE End Plug Accumulator Control Valve

Packaging Pocket 4

- End Plug, Extra Large
- O-Rings (2) 1 Extra

Step 5 Replace OE Lockup Assembly

Packaging Pocket 5

- Valve
- Sleeve

Step 6 Select Correct Replacement EPC Boost Valve



Look at end of the OE boost sleeve for number of identification dots. If replacing an OE sleeve with NO dots or three dots, use the Sonnax EPC boost valve with flat on large spool diameter. If replacing an OE sleeve with two dots, use the Sonnax EPC boost valve with flat on small spool diameter. (See page 8 of Installation & Testing Booklet for more details.)

Packaging Pocket 6

- EPC Boost Valve Flat on Large Spool Dia. (for no/three ID dots)
- EPC Boost Valve Flat on Small Spool Dia. (for two ID dots)

Step 7 Assemble Boost Assembly



Place small reverse valve into sleeve. Place selected EPC boost valve from step 6 into sleeve, smaller diameter first. Place cutback boost valve into sleeve with longer stem facing outboard.

Packaging Pocket 7

- Boost Sleeve
- Reverse Boost Valve
- Cutback Boost Valve

Step 8 Pressure Regulator Valve Shims



Look at the end of OE boost sleeve for the number of identification dots. If replacing an OE sleeve with two or three dots, do NOT add shim. If replacing an OE sleeve with no dots, add both shims. Shims should be added, if used, between the OE washer and pressure regulator valve. (See page 8 of installation and testing booklet for more details.)

Packaging Pocket 8

- Shim, .015" thick
- Shim, .032" thick

Step 9 Replace OE Large Checkballs



See checkball caution notes on page 1.

Packaging Pocket 9

- Checkballs, Large .250" dia. (2)

Step 10 Replace OE Small Checkballs



See checkball caution notes on page 1.

Packaging Pocket 10

- Checkballs, Small .218" dia. (9)

The parts listed here may be protected by patent number 8,955,533.



Toyota/Lexus A340E, A340F '00-Later, V6 & V8 ZIP KIT®

PART NUMBER **A340-LATE-ZIP**

INSTALLATION & TESTING BOOKLET

Valve Body Identification

This Zip Kit **A340-LATE-ZIP** is designed for 2000-later, V6 & V8 applications using Type 3 (valve body casting identification #8935) or Type 4 (valve body casting identification #8938) style valve bodies.

Type 3 (Casting ID #8935) Valve Body

V8 applications, EPC style throttle control only.

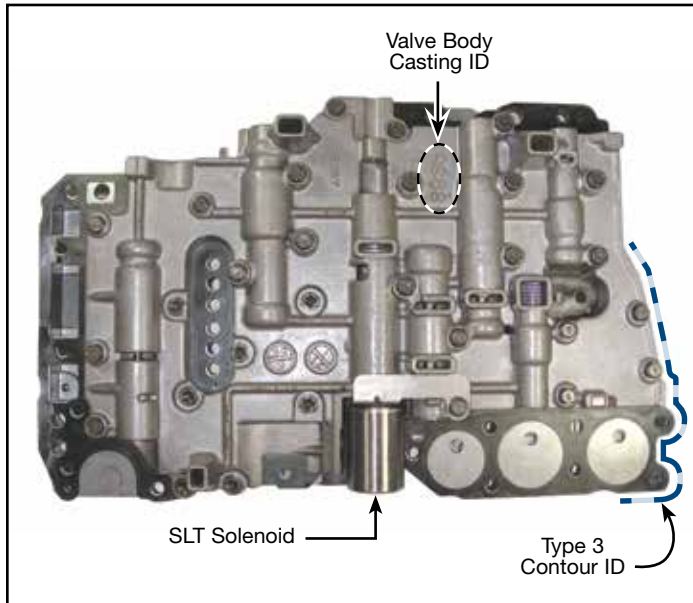

Figure 1 Type 3, Upper Valve Body

Type 4 (Casting ID #8938) Valve Body

V6 or V8 applications, EPC (shown) or throttle cable style throttle control.

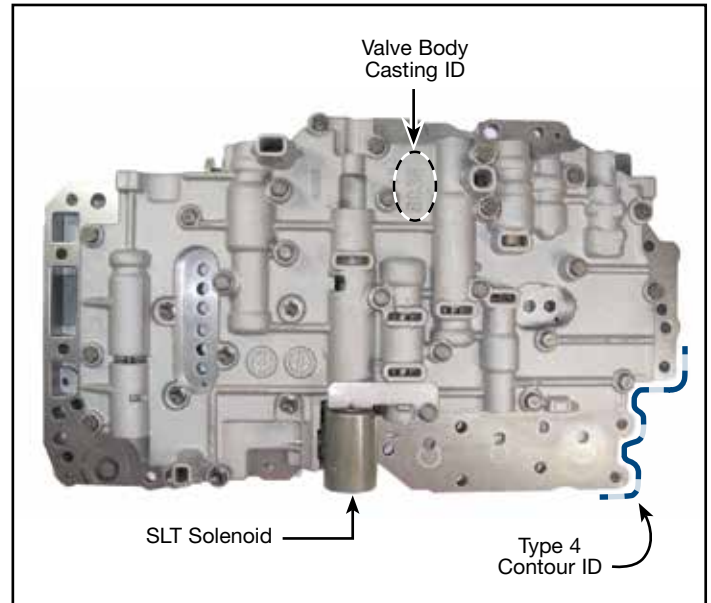

Figure 3 Type 4, Upper Valve Body

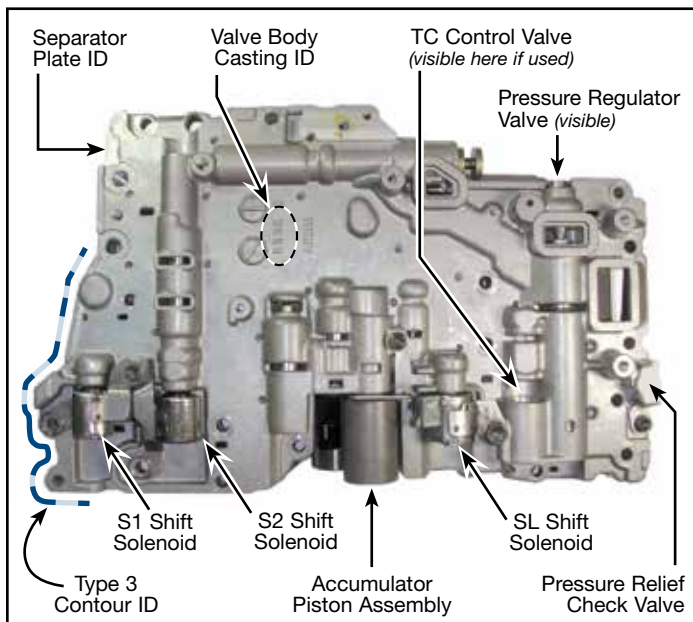

Figure 2 Type 3, Lower Valve Body

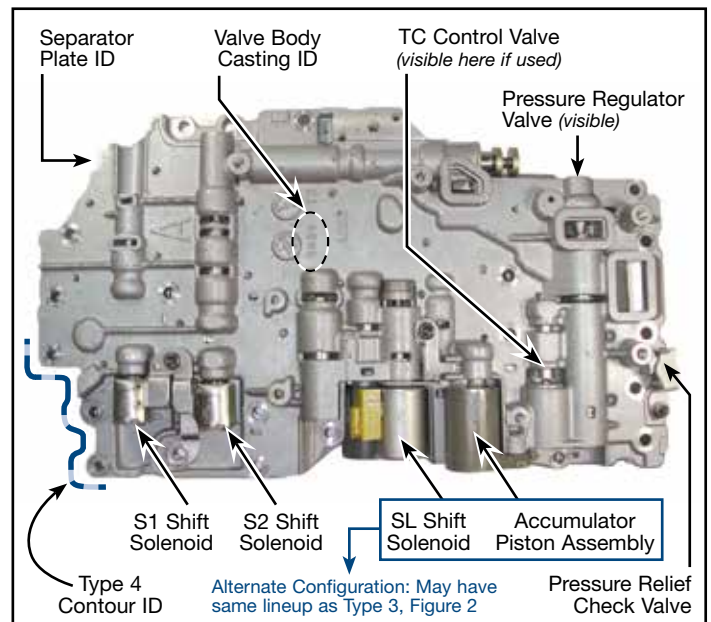

Figure 4 Type 4, Lower Valve Body

Bolt Locations & Torque Specifications

Torque Specifications		Type 3 Valve Body to Case Bolts		Type 4 Valve Body to Case Bolts		Type 3 & 4 Oil Pan Filter Bolts		Type 3 & 4 Valve Body Disassembly Bolts		
		Bolt Color Code	Bolt Length	Bolt Color Code	Bolt Length	Bolt Color Code	Bolt Length	Bolt Color Code	Bolt Length	
Detent Spring Bolt 89 in-lbs (10 N.m)		1	Red	23mm	1	Purple	23mm	A	Pink	14mm
Oil Pan Bolt 65 in-lbs (7.3 N.m)		2	Green	28mm	2	White	28mm	B	Black	20mm
Solenoid-to-Valve Body Bolt 89 in-lbs (10 N.m)		3	Blue	36mm	3	Yellow	36mm	C	Orange	23mm
		Torque all to 8 ft-lbs		Torque all to 8 ft-lbs		Torque to 7 ft-lbs		Torque to 57 in-lbs		

Type 3 (Casting ID #8935) Valve Body

V8 applications, EPC style throttle control only.

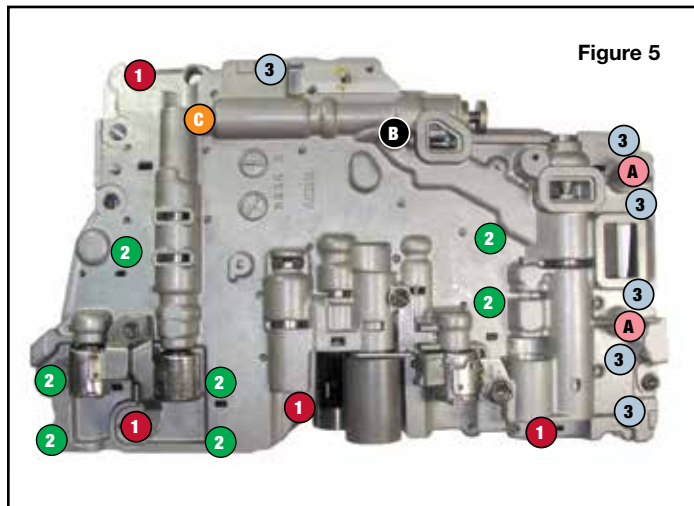

Type 3, Lower Valve Body, **Case Removal** - Bolt Locations

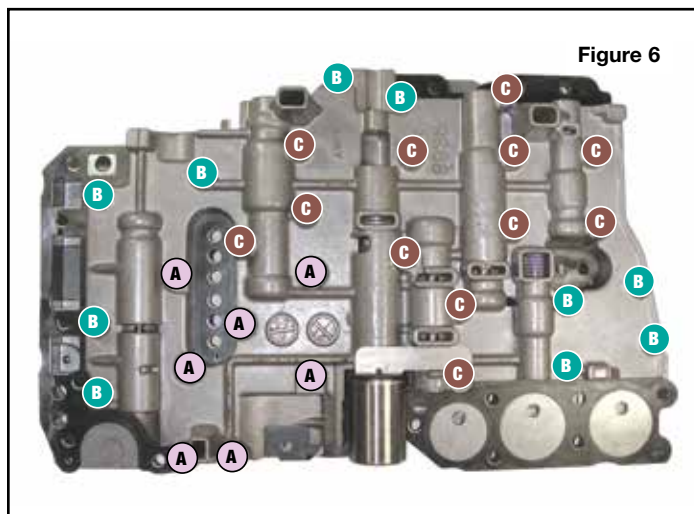

Type 3, Upper Valve Body, **Valve Body Disassembly** - Bolt Locations

Type 4 (Casting ID #8938) Valve Body

V6 or V8 applications, EPC (shown) or throttle cable style throttle control.

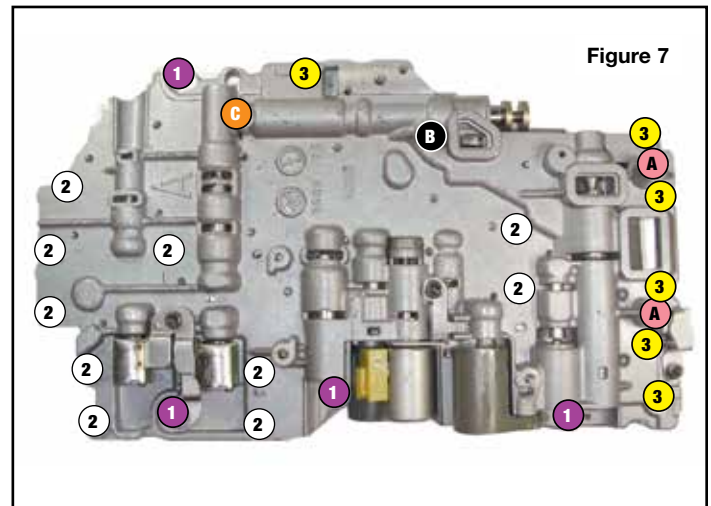

Type 4, Lower Valve Body, **Case Removal** - Bolt Locations

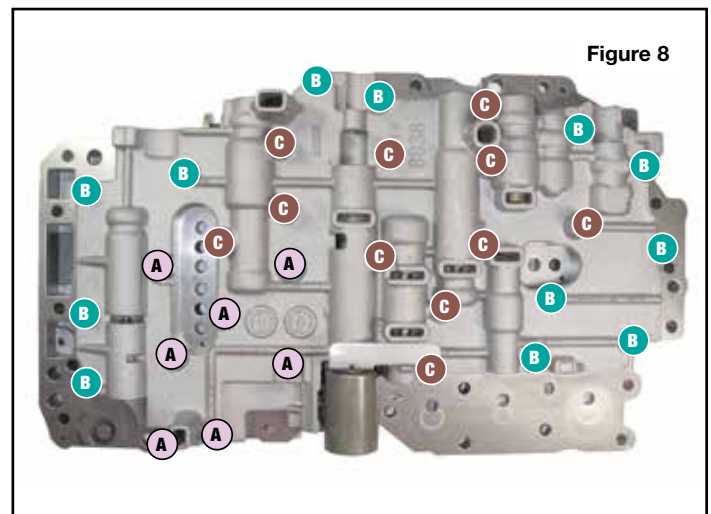

Type 4, Upper Valve Body, **Valve Body Disassembly** - Bolt Locations

Clutch & Band Application Chart

Selector Position - Gear	C0	C1	C2	B0	B1	B2	B3	F0	F1	F2
Park	ON									
Reverse	ON		ON				ON	ON		
Neutral	ON									
D-1st Gear	ON	ON						ON		ON
D-2nd Gear	ON	ON				ON		ON	ON	
D-3rd Gear	ON	ON	ON			ON		ON		
D-Overdrive		ON	ON	ON		ON				
2-1st Gear	ON	ON						ON		ON
2-2nd Gear	ON	ON			ON	ON		ON	ON	
2-2nd Gear	ON	ON	ON			ON		ON		
Low-1st Gear	ON	ON					ON	ON		ON
Low-2nd Gear	ON	ON			ON	ON		ON	ON	

Figure 9 **Shift Solenoid Chart**

Figure 10

Selector Position - Gear	Shift Solenoid S1	Shift Solenoid S2
D - 1st Gear	ON	Off
D - 2nd Gear	ON	ON
D - 3rd Gear	Off	ON
D - Overdrive	Off	Off
2 - 1st Gear	ON	Off
2 - 2nd Gear	ON	ON
2 - 3rd Gear	Off	ON
Low - 1st Gear	ON	Off
Low - 2nd Gear	ON	ON

Solenoid Diagnostic Trouble Chart

DTC	Description
P0750	Shift Solenoid S1 (A)/S2 (B) Malfunction
P0753	Shift Solenoid S1 (A)/S2 (B) Electrical Malfunction
P0755	Shift Solenoid S1 (A)/S2 (B) Malfunction
P0758	Shift Solenoid S1 (A)/S2 (B) Electrical Malfunction
P0770	Shift Solenoid SL (E) Malfunction
P0773	Shift Solenoid SL (E) Electrical Malfunction

Figure 11

Solenoid Malfunctioning Shift Strategies

Selector Position - Normal Gear	Shift Solenoid S1 (A) Malfunctioning			Shift Solenoid S2 (B) Malfunctioning			Both Solenoids Malfunctioning
	S1 (A)	S2 (B)	Gear	S1 (A)	S2 (B)	Gear	Gear When selector position in manually operated
D-1st Gear	X	ON	3rd	ON	X	1st	Overdrive
D-2nd Gear	X	ON	3rd	Off	X	O/D	Overdrive
D-3rd Gear	X	ON	3rd	Off	X	O/D	Overdrive
D-Overdrive	X	Off	O/D	Off	X	O/D	Overdrive
2-1st Gear	X	ON	3rd	ON	X	1st	3rd
2-2nd Gear	X	ON	3rd	Off	X	3rd	3rd
2-2nd Gear	X	ON	3rd	Off	X	3rd	3rd
Low-1st Gear	X	Off	1st	ON	X	1st	1st
Low-2nd Gear	X	ON	2nd	ON	X	1st	1st

Figure 12

Shift Strategies

The computer (ECM) controls the ON/Off combination of the shift solenoids S1 (A) and S2 (B) to shift between 1st gear and overdrive (O/D). If an electrical failure occurs in one of these two solenoids, the computer continues to control the other solenoid to allow the vehicle to operate as smoothly as possible while in Fail Safe mode. The ECM also turns off the SL (E) solenoid during Fail Safe. Should both solenoids S1 (A) and S2 (B) fail, shifting must be done manually. **Figures 11 and 12** give typical solenoid codes and solenoid malfunctioning shift strategies.



Figure 13



Figure 14

To test shift solenoids S1 (A), S2 (B) or SL (E) for sticking, force 71 psi of compressed air into the snout (**Figure 13, arrow**); it should not leak. Energizing the solenoids should cause them to open and allow air flow. Resistance on these three shift solenoids should be 11–15 ohm at 68°F, and resistance on the SLT solenoid should be 5.0–5.6 ohm at 68°F.

Some valve bodies have an accumulator piston assembly (**Figure 14**) that can be mistaken for a solenoid. This is actually an accumulator for lockup and should be checked to ensure the piston can move freely.

Critical Wear Areas & Vacuum Test Locations



Drop-In Zip Valve™
Parts Available

NOTE: OE valves are shown in rest position and should be tested in rest position unless otherwise indicated. Test locations are pointed to with an arrow. Springs are not shown for visual clarity. Low vacuum reading indicates wear and Sonnax parts are noted for replacement.

Upper Valve Body • Type 3, EPC Style



For specific vacuum test information, refer to individual part instructions included in kits and available at www.sonnax.com.

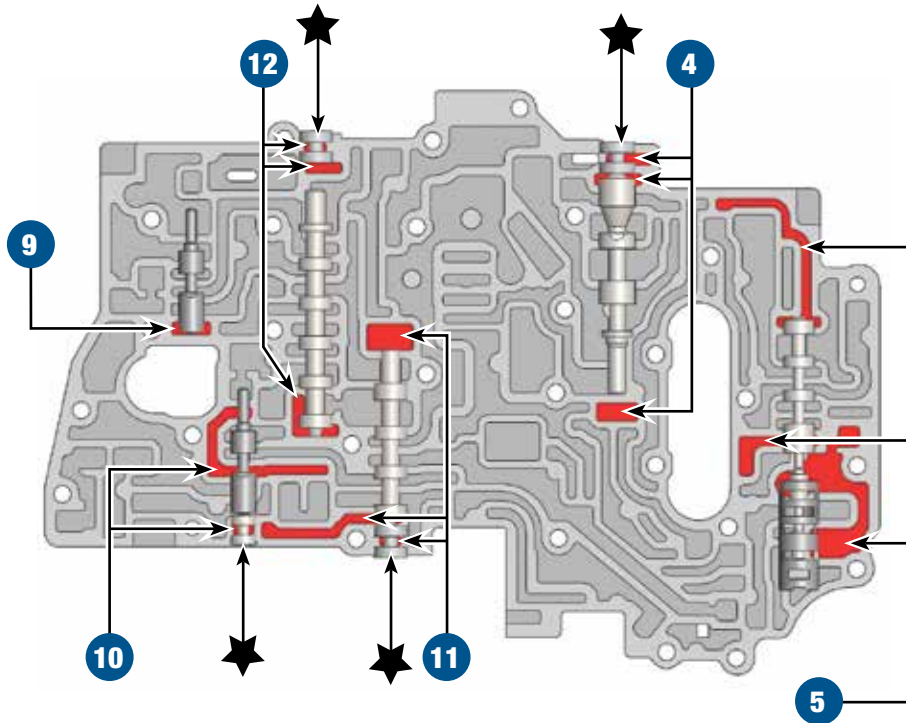

1. Primary Regulator Valve

- Low line pressure • High line pressure
- Poor shift quality • Low lube oil flow
- Burnt clutches

Replace with **Sonnax Part No.**

97741-06K EPC valve spool .426" dia.;
replaces OE 2-dot boost sleeve or
97741-10K EPC valve spool .353" dia.;
replaces OE 3-dot or no-dot boost sleeve
97741-06K & 97741-10K: Requires F-97741-TL6 & VB-FIX

2. Boost Assembly

- Delayed Forward or Reverse
- Soft shifts
- Low pressure

Replace with **Sonnax Part No. 97741-01K***

3. TCC Control Valve & Plunger Assembly

- TCC apply & release concerns
- TCC codes • Overheated fluid
- Burnt converter

Lower Valve Body • Type 3, EPC Style

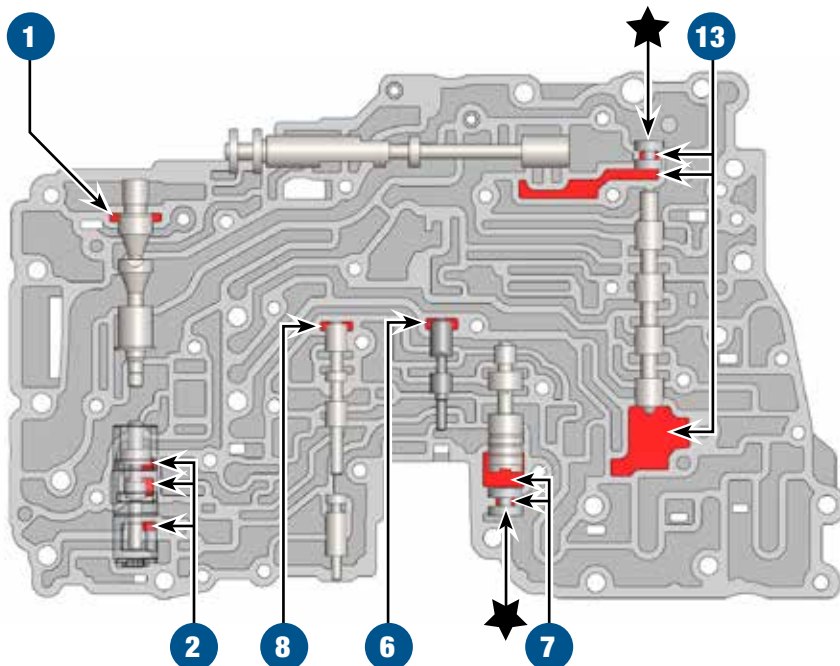

4. Secondary Regulator Valve

- TCC apply & release concerns
- Burnt TCC apply components
- Overheated transmission
- Bushing wear

Replace with **Sonnax Part No.**

97741-18K Requires F-97741-TL18* & VB-FIX

5. Lockup Relay Valve & Plunger Assembly

- TCC apply & release concerns
- TCC codes • RPM fluctuation
- Inadequate lubrication
- Bushing failure • Overheated fluid

Replace with **Sonnax Part No.**

77741-02K* Lockup Relay Control Valve Kit or
97741-20K Oversized Lockup Relay Valve Kit
97741-20K: Requires F-97741-TL20 & VB-FIX

6. Secondary Modulator Valve

- Shift concerns
- Solenoid codes

Part numbers with an asterisk () are included in this Zip Kit. †Required tool kit F-97741-TL18 is no longer in production. Check with distributor for availability.

7. Accumulator Control Valve

- Shift concerns
- Solenoid codes
- Loss of throttle/line pressure

8. Cutback Valve

- No kickdown
- Loss of throttle pressure

9. Low Coast Modulator Valve

- Burnt 1st/Reverse brake (B3)
- Loss of manual low

10. 2nd Coast Modulator Valve

- Burnt 2nd brake (B2)
- Loss of manual 2nd

11. 3-4 Shift Valve

3-4 Concerns

12. 2-3 Shift Valve

2-3 Concerns

13. 1-2 Shift Valve

1-2 Concerns

14. Reverse Control Valve

- Delayed Reverse
- No Reverse

15. End Plugs ZIP

- Soft shifts
- Low line rise
- Slips & flares

Replace with Sonnax Part No.

97741-19K*

NOTE: Several Locations = ★

Upper Valve Body • Type 4, EPC Style

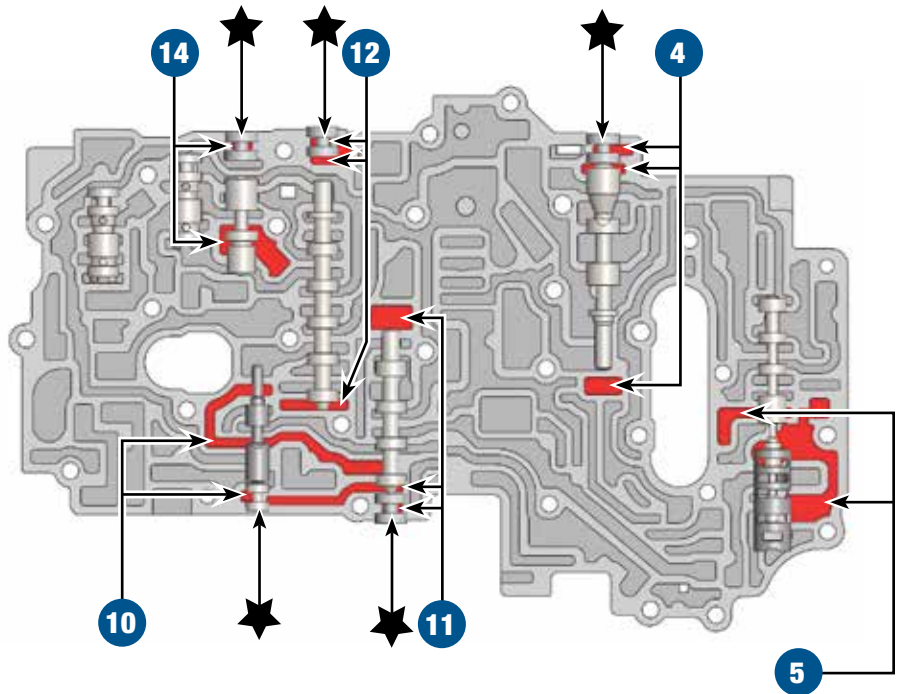

Lower Valve Body • Type 4, EPC Style

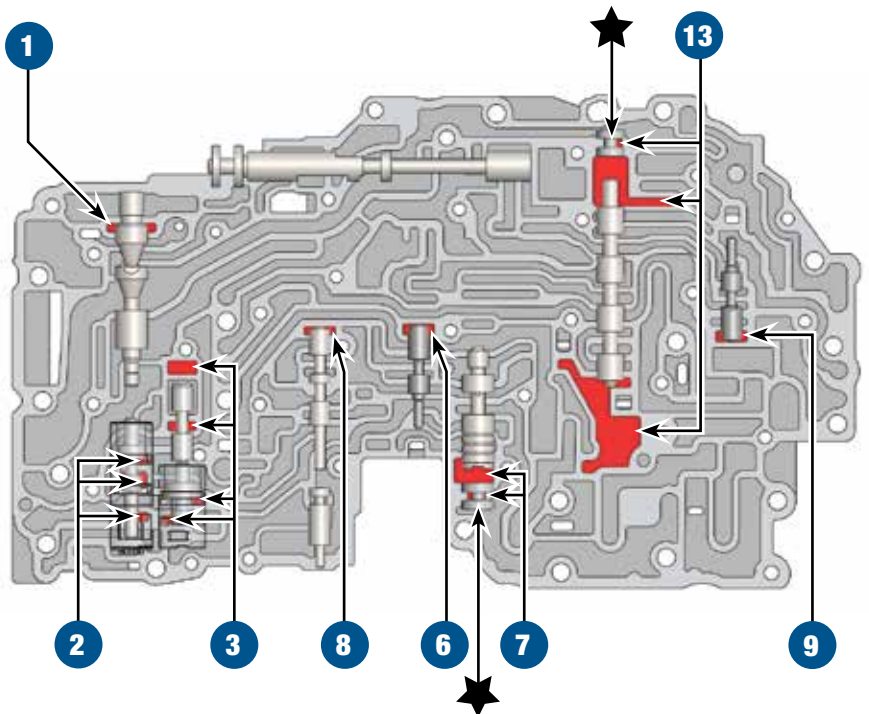

OE Exploded View

Upper & Lower Valve Body • Type 3, EPC Style Shown Here

NOTE: Depending upon vehicle application, the OE springs shown may not be present.

Upper Valve Body - Type 3

Checkball Cautions & Notes

- Care should be taken during disassembly. Note location of checkballs as usage varies greatly!

- When determining when a checkball is required, the circuit orifice in the separator plate over that location will be about .090" dia. When no ball is required, the orifice will be about .150" dia.
- All checkballs are .218" dia. except where noted (.250" dia.).

Upper Valve Body Descriptions	
I.D. No.	Description
101	Lockup Relay Valve & Plunger Assembly
102	3-4 Shift Valve
103	2nd Coast Modulator Valve
104	Low Coast Modulator Valve
105	2-3 Shift Valve
106	Secondary Regulator Valve

Lower Valve Body Descriptions	
I.D. No.	Description
201	Accumulator Control Valve
202	Secondary Modulator Valve
203	Cutback Valve
204	Primary Regulator Valve & Boost Assembly
205	Converter Limit Valve
206	Manual Valve
207	1-2 Shift Valve

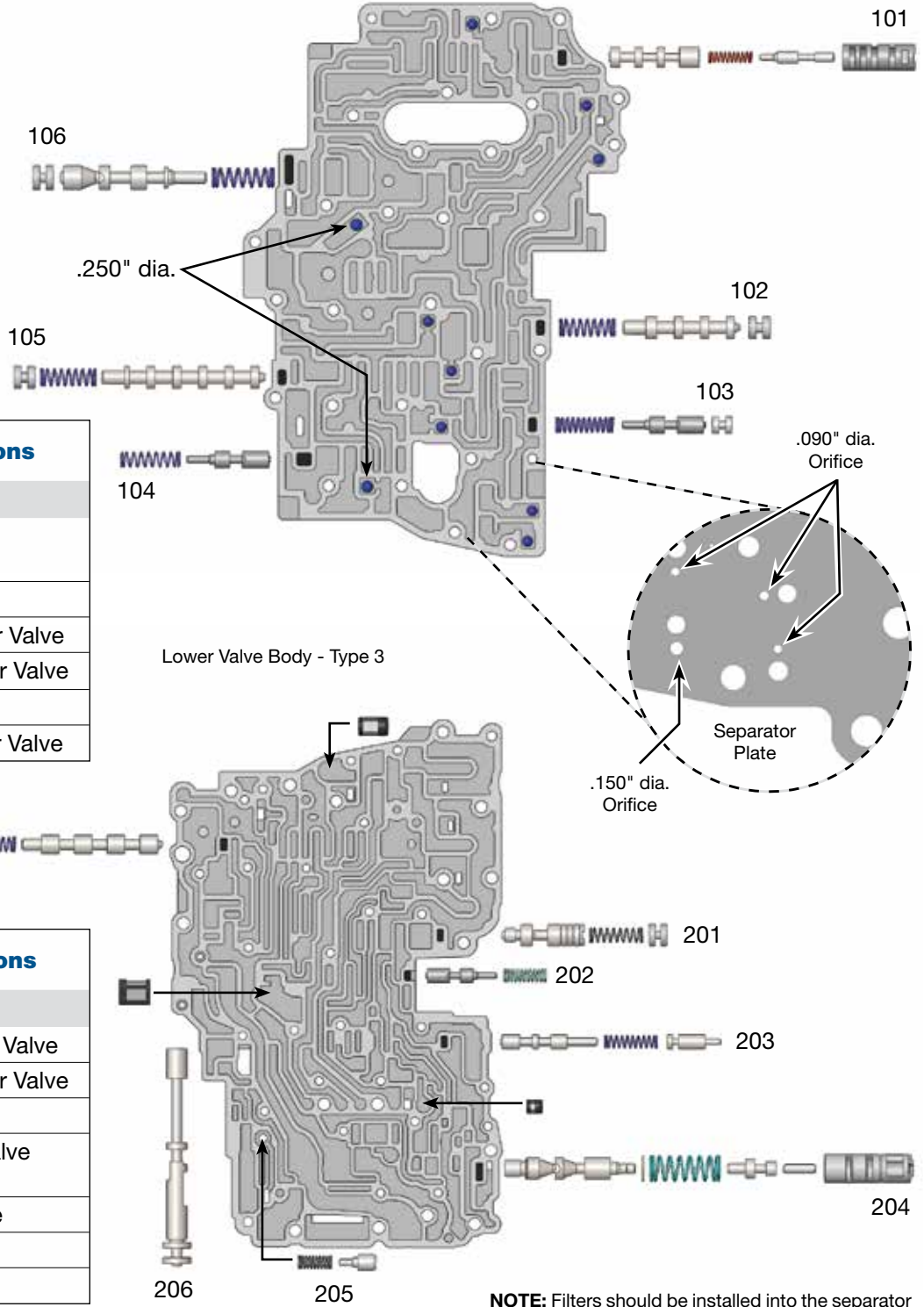



NOTE: Filters should be installed into the separator plate during assembly. The open end of the filter snaps into the plate opening.

Upper & Lower Valve Body • Type 4, EPC Style Shown Here

NOTES: Depending upon vehicle application, the OE springs shown may not be present. Slight wormtrack difference and valve components will vary in throttle cable style valve bodies.

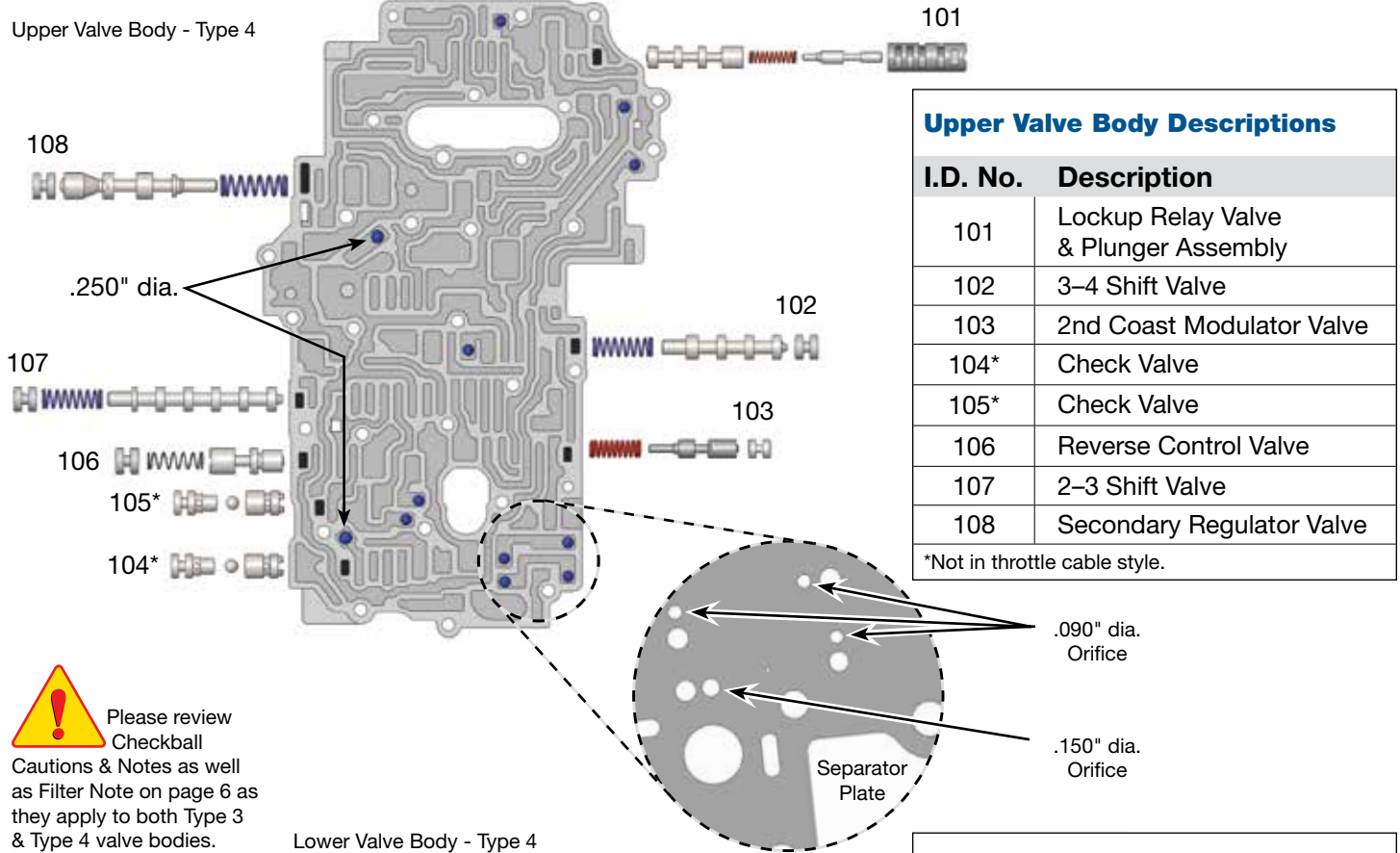
Upper Valve Body - Type 4



 Please review Checkball Cautions & Notes as well as Filter Note on page 6 as they apply to both Type 3 & Type 4 valve bodies.

Lower Valve Body - Type 4

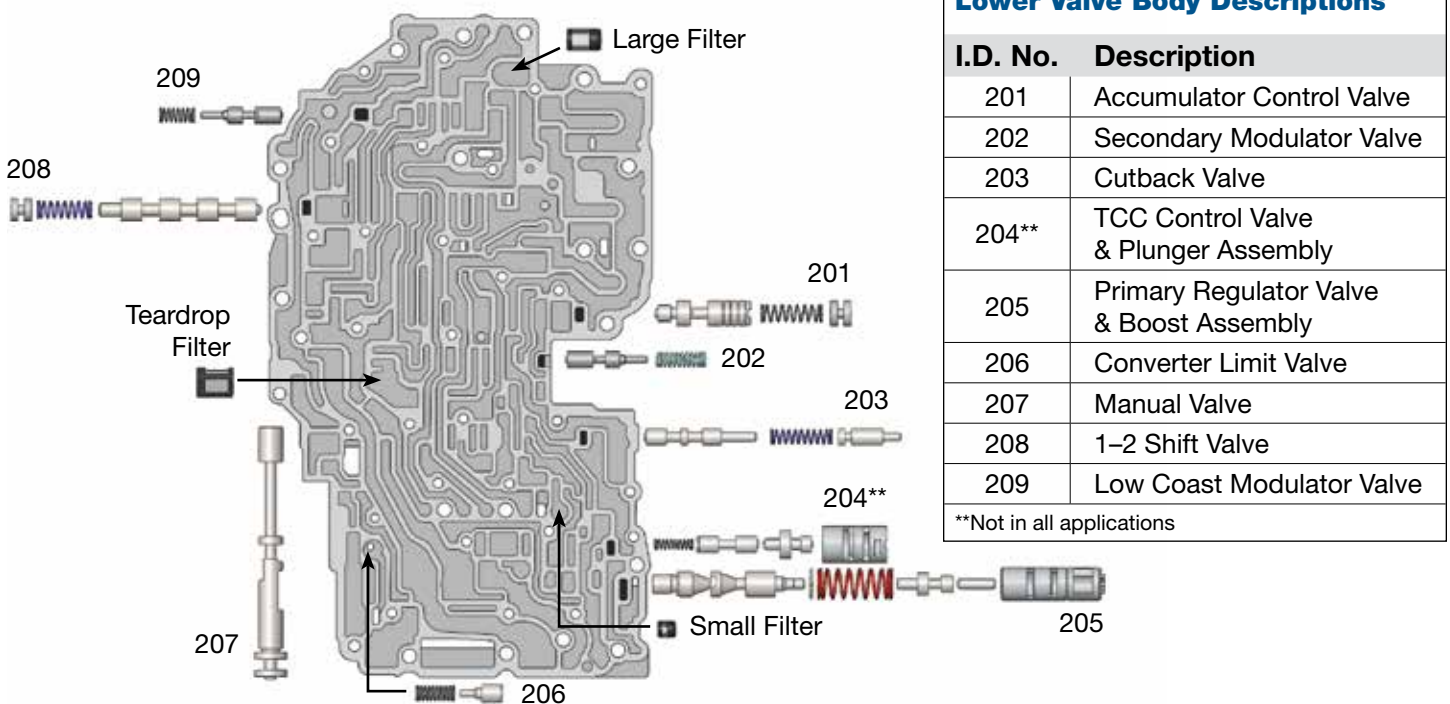

Detailed Instructions for Steps 6 to 8 from Quick Guide

