

Oversized VSTV Pilot Pressure Valve



Part No.
33741B-06

Tool Kit



Part No.
F-33741B-TL6

- Reamer
- Reamer Jig
- Guide Pin

NOTE: This tool kit can be used for both 01T (33741B-07) and 01J (33741B-06) VSTV valves. Ensure correct valve is installed into casting being worked on (Figure 1).

Sonnax "F-Tool" kits designed to service a specific bore require the VB-FIX, a self-aligning valve body reaming fixture. More information and instructions can be found online at www.sonnax.com.

Also Available

Oversized VSTV Pilot Pressure Valve
33741B-07

01T

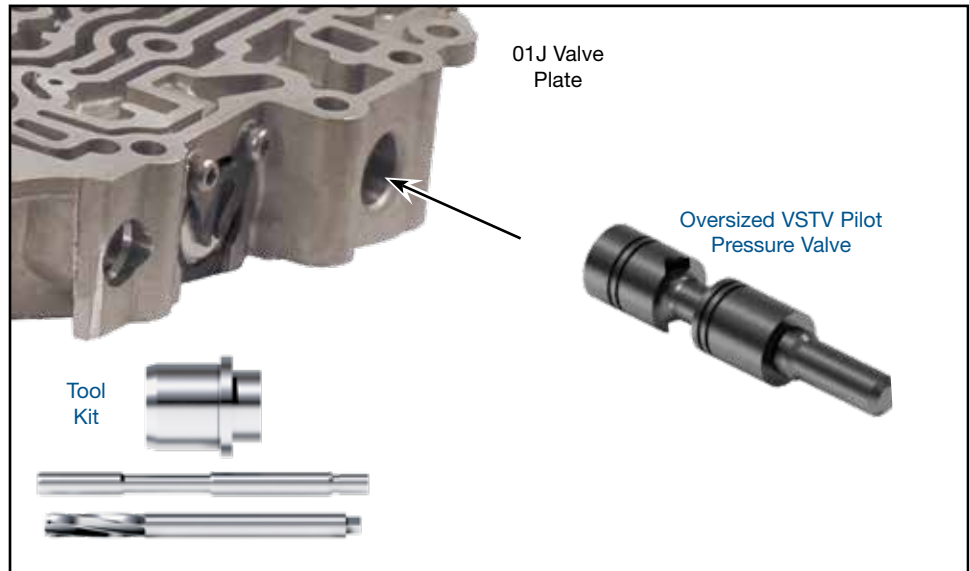

VW/Audi 01J

NOTE: Before beginning work, verify valve plate is 01J (Figure 1).

1. Disassembly

- Remove OE retainer, end plug and spring and save for reuse.
- Remove and discard OE valve.

2. Bore Preparation

Ream VSTV/pilot pressure bore (for reaming instructions/reamer care, please visit www.sonnax.com). Sonnax reaming tool kit F-33741B-TL6 and VB-FIX are required for this operation.

3. Installation & Assembly

- Ensure all debris has been removed from valve bore and valve body.
- Install Sonnax valve, spring stem outward.
- Reinstall OE spring and end plug. Secure with OE retainer.

4. Final Testing

Vacuum testing at the port(s) indicated holds the recommended minimum 18 in-Hg (Figure 2).

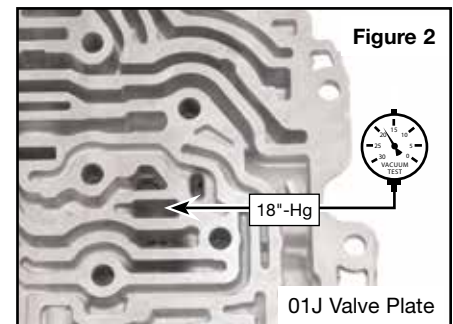
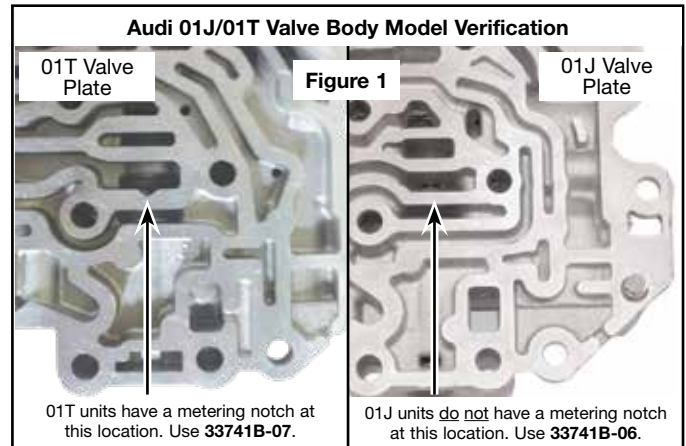

Oversized VSTV Pilot Pressure Valve



Part No.
33741B-07

Tool Kit



Part No.
F-33741B-TL6

- Reamer
- Reamer Jig
- Guide Pin

NOTE: This tool kit can be used for both 01T (33741B-07) and 01J (33741B-06) VSTV valves. Ensure correct valve is installed into casting being worked on (Figure 1).

Sonnax "F-Tool" kits designed to service a specific bore require the VB-FIX, a self-aligning valve body reaming fixture. More information and instructions can be found online at www.sonnax.com.

Also Available

Oversized VSTV Pilot Pressure Valve
33741B-06

01J

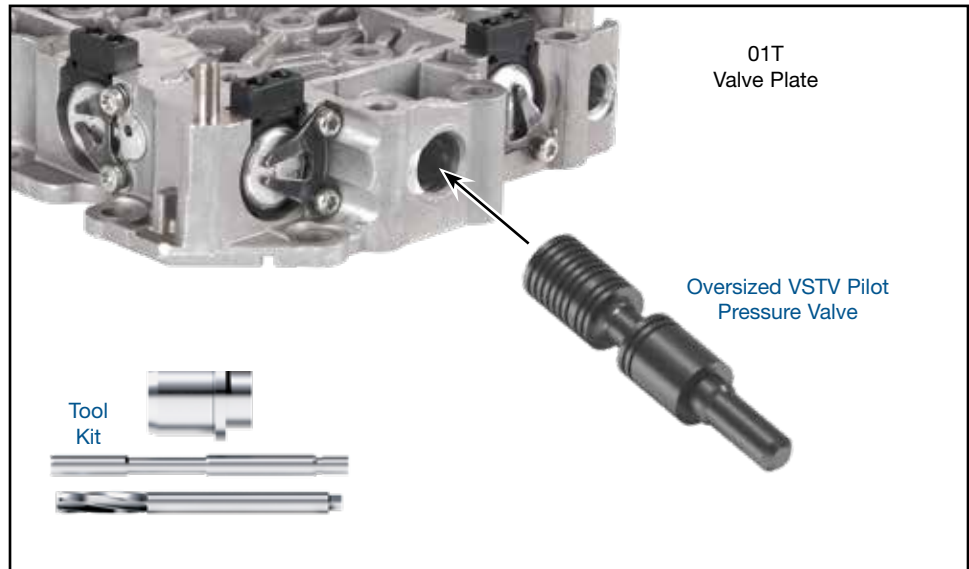

NOTE: Before beginning work, verify valve plate is 01T (Figure 1).

1. Disassembly

- Remove OE retainer, end plug and spring and save for reuse.
- Remove and discard OE valve.

2. Bore Reaming

Ream VSTV/pilot pressure bore (for reaming instructions/reamer care,

please visit www.sonnax.com). Sonnax reaming tool kit F-33741B-TL6 and VB-FIX are required for this operation.

3. Installation & Assembly

- Ensure all debris has been removed from valve bore and valve body.
- Install Sonnax valve, spring stem outward.
- Reinstall OE spring and end plug. Secure with OE retainer.

4. Final Testing

Vacuum testing at the port(s) indicated holds the recommended minimum 18 in-Hg.

