

Oversized Secondary Regulator Valve Kit

Part No.
59947-16K



- Valve
- Spring

NOTE: Also fits AF23/33 & RE5F22A units.

Tool Kit

Part No.
F-59947-TL16



- Reamer
- Reamer Jig
- Guide Pin

NOTE: Sonnax “F-Tool” kits designed to service a specific bore require the VB-FIX, a self-aligning valve body reaming fixture. More information and instructions can be found online at www.sonnax.com.

Aisin AW 55-50SN, 55-51SN

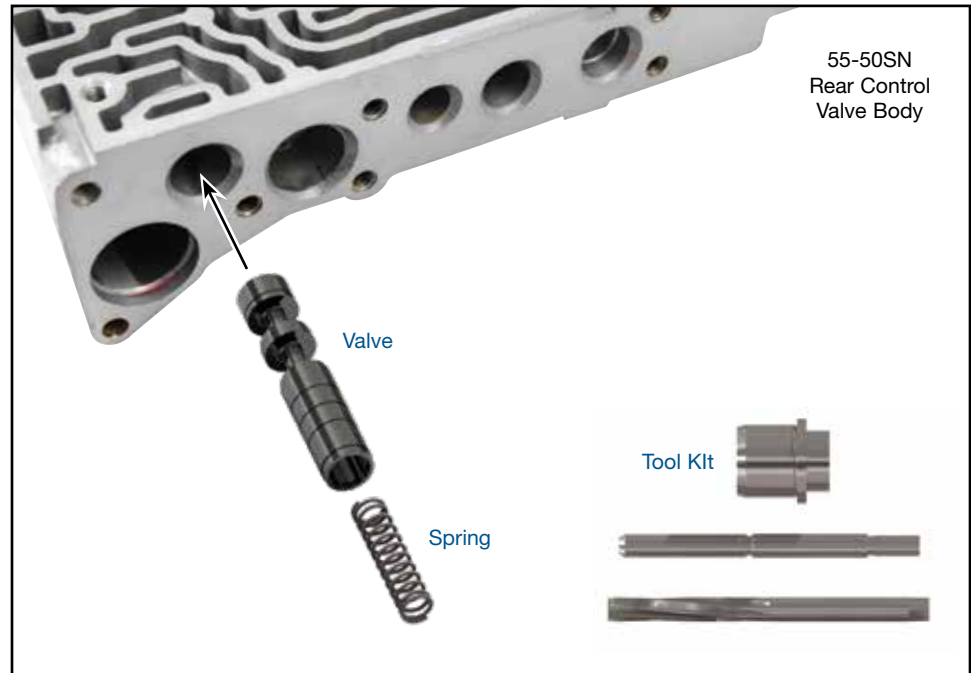

1. Disassembly

- Remove all OE components from the bore.
- Save OE retainer plate and bolts for reuse.
- Discard valve and spring.

2. Bore Reaming

Ream secondary regulator bore (for reaming instructions/reamer care, please visit www.sonnax.com). Sonnax reaming tool kit **F-59947-TL16** and **VB-FIX** are required for this operation.

3. Installation & Assembly

- Be certain all debris has been removed from the valve bore and valve body.
- Install Sonnax secondary regulator valve with spring pocket outboard.
- Install Sonnax spring into valve spring pocket.
- Reinstall OE retainer plate and bolts, securing Sonnax parts in place.

4. Final Testing

Vacuum testing at the port(s) indicated holds the recommended minimum 18 in-Hg.

