

## Oversized Pressure Regulator Valve Kit

**Part No.**  
**68942-07K**



- Valve
- Inner Spring
- Outer Spring



**NOTE:** Fits bores containing OE pressure regulator valve with .512" dia. spool only.

## Tool Kit

**Part No.**  
**F-68942-TL7**



- Reamer
- Reamer Jig
- Guide Pin

**NOTE:** Sonnax "F-Tool" kits designed to service a specific bore require the VB-FIX, a self-aligning valve body reaming fixture. More information and instructions can be found online at [www.sonnax.com](http://www.sonnax.com).

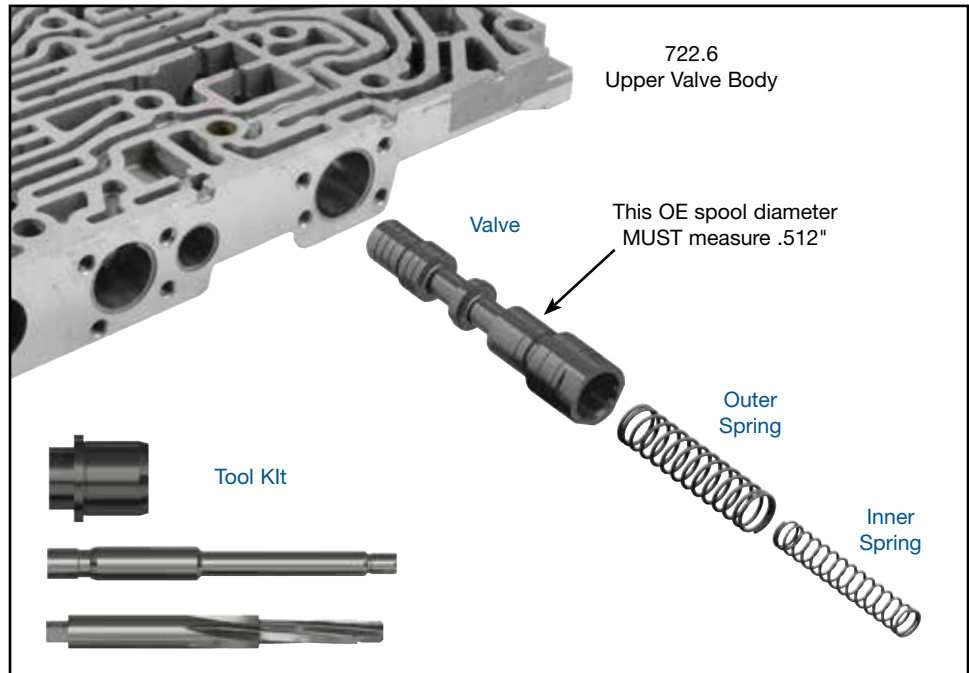

## Mercedes 722.6

### 1. Disassembly

- Remove OE retainer plate and set aside for reuse.
- Remove and discard OE spring and valve.

### 2. Bore Reaming

Ream pressure regulator bore (for reaming instructions/reamer care, please visit [www.sonnax.com](http://www.sonnax.com)). Sonnax reaming tool kit **F-68942-TL7** and **VB-FIX** are required for this operation.

### 3. Installation & Assembly

- Ensure all debris is cleaned and removed from valve bore and body.
- Install Sonnax pressure regulator valve.
- Install Sonnax inner spring.
- Install Sonnax outer spring.



**NOTE:** To prevent spring side-loading, ensure springs are aligned in bore when installing retaining plate.

- Reinstall OE retainer plate.

### 4. Final Testing

Vacuum testing at the port(s) indicated holds the recommended minimum 18 in-Hg.

