

Oversized 1-2 Accumulator Valve

Part No.
84754-57K



Tool Kit

Part No.
F-84754-TL57



- Reamer
- Reamer Jig
- Guide Pin

NOTE: Sonnax “F-Tool” kits designed to service a specific bore require the VB-FIX, a self-aligning valve body reaming fixture. More information and instructions can be found online at www.sonnax.com.

WARNING: Required tool kit 84754-TL57 is no longer in production. Check with your distributor for availability.

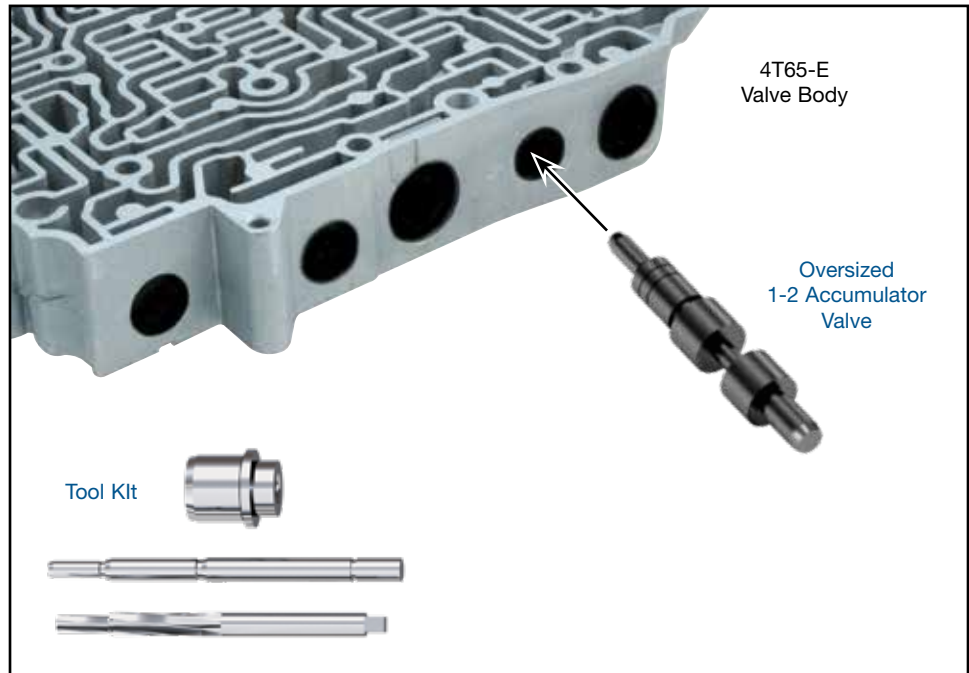

1. Disassembly

- Remove OE retainer, plug, valve and spring.
- Discard OE valve.
- Save OE plug, retainer and spring for reuse.

2. Bore Reaming

Ream accumulator bore (for reaming instructions/reamer care, please visit www.sonnax.com). Sonnax reaming tool kit **F-84754-TL57** and **VB-FIX** are required for this operation.

3. Installation & Assembly

- Place OE spring onto narrow spring stem of oversized valve.
- Install spring and valve into reamed bore, spring end first.
- Install OE plug into bore and retain with OE retainer.

4. Final Testing

Vacuum testing at the port(s) indicated holds the recommended minimum 18 in-Hg.

