

Oversized Pressure Regulator Valve



Part No.

85755-02

NOTE: Fits late (E18.2) valve body (Figure 1).

Tool Kit



Part No.

F-85755-TL2

- Reamer
- Reamer Jig
- Guide Pin

NOTE: Sonnax "F-Tool" kits designed to service a specific bore require the VB-FIX, a self-aligning valve body reaming fixture. More information and instructions can be found online at www.sonnax.com.

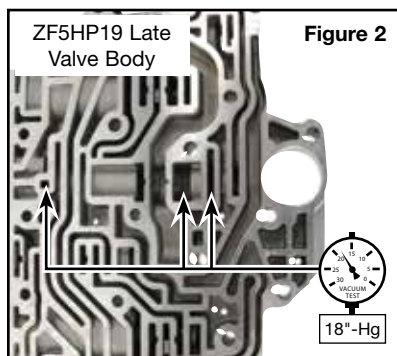
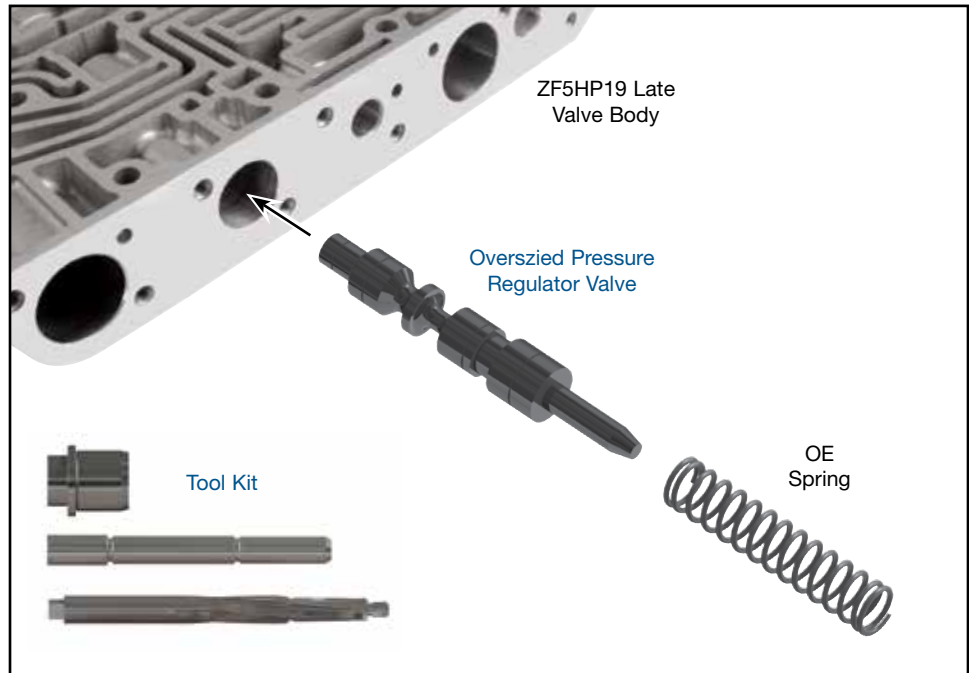

1. Disassembly

- Remove the valve body casting end plate.
- Remove OE spring and save for reuse.
- Remove OE valve and discard.

2. Bore Reaming

Ream pressure regulator bore (for reaming instructions/reamer care, please visit www.sonnax.com). Sonnax reaming tool kit **F-85755-TL2** and **VB-FIX** are required for this operation.

3. Installation & Assembly

- Be certain all debris has been removed from the valve bore and valve body.
- Install Sonnax valve.
- Install OE spring.
- Reattach OE valve body casting end plate.

4. Final Testing

Vacuum testing at the port(s) indicated holds the recommended minimum 18 in.-Hg (Figure 2).

