

## Reverse Boost Valve Kit

**Part No.**  
**K77898**

- Valve
- Sleeve
- O-Rings (2)

**NOTE:** Large ratio, O-ring style.

## GM 200-4R, 4L60

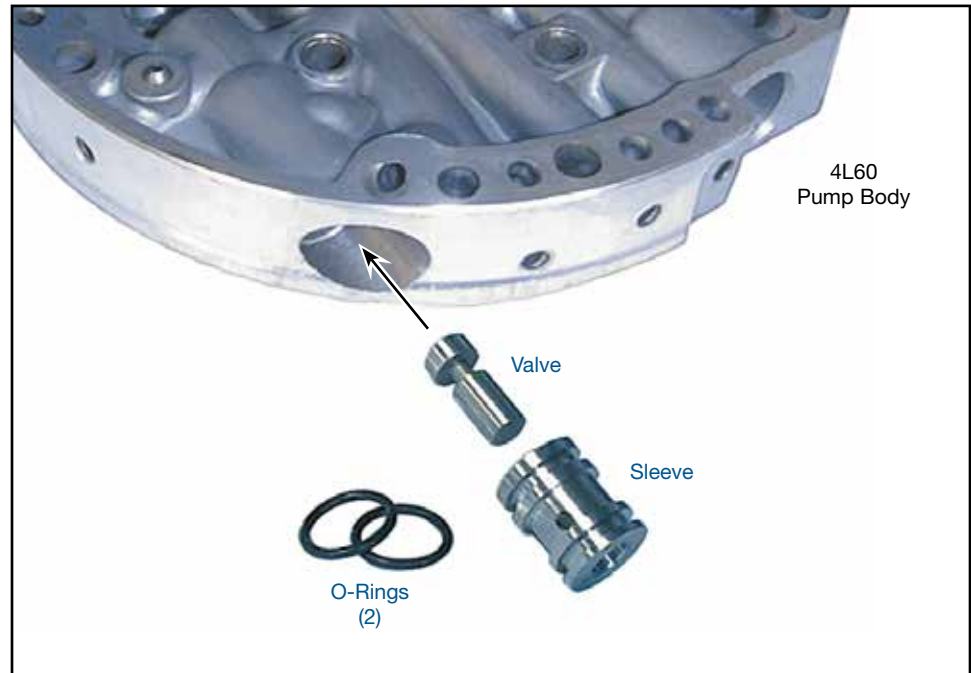

### 1. Disassembly

Remove and discard the worn boost valve assembly.

### 2. Installation & Assembly

- Lubricate all Sonnax parts and install the two Sonnax O-rings in the grooves on the Sonnax sleeve.
- Insert Sonnax boost valve and sleeve assembly into bore.



**NOTE:** Ensure proper OE sequence is followed (**Figure 1**). Incorrect installation can result in soft 2-3 shifts, low line pressure, erratic shifts and slipping in Reverse.

### 3. Final Testing

Vacuum testing at the port(s) indicated holds the recommended minimum 18 in-Hg (**Figure 2**).

