

Ford 4R70E, 4R70W, 4R75E, 4R75W, AOD, AODE; GM TH180, TH180C (3L30), 4L30-E

Servo Pin Bore Sleeve

Part No.
76890-24K

Tool Kit

Part No.
S-76890-TL24



- Drill
- Reamers (2)
- Reamer Jig
- Guide Pin
- Installation Tool Handle
- Installation Tool Pilot
- O-Rings (2)
- Bore Guide AOD
- Bore Guide AODE
- Bore Guide 180 & 4L30-E

NOTE: Sonnax has designed special tool kits to service a specific servo pin bore, and they must be used in conjunction with the servo pin bore reaming fixture **SERVO-FIX**. Part numbers for these specially designed tool kits begin with an "S" to distinguish them from both the F-series tools that work with the VB-FIX and the traditional Sonnax tool kits.

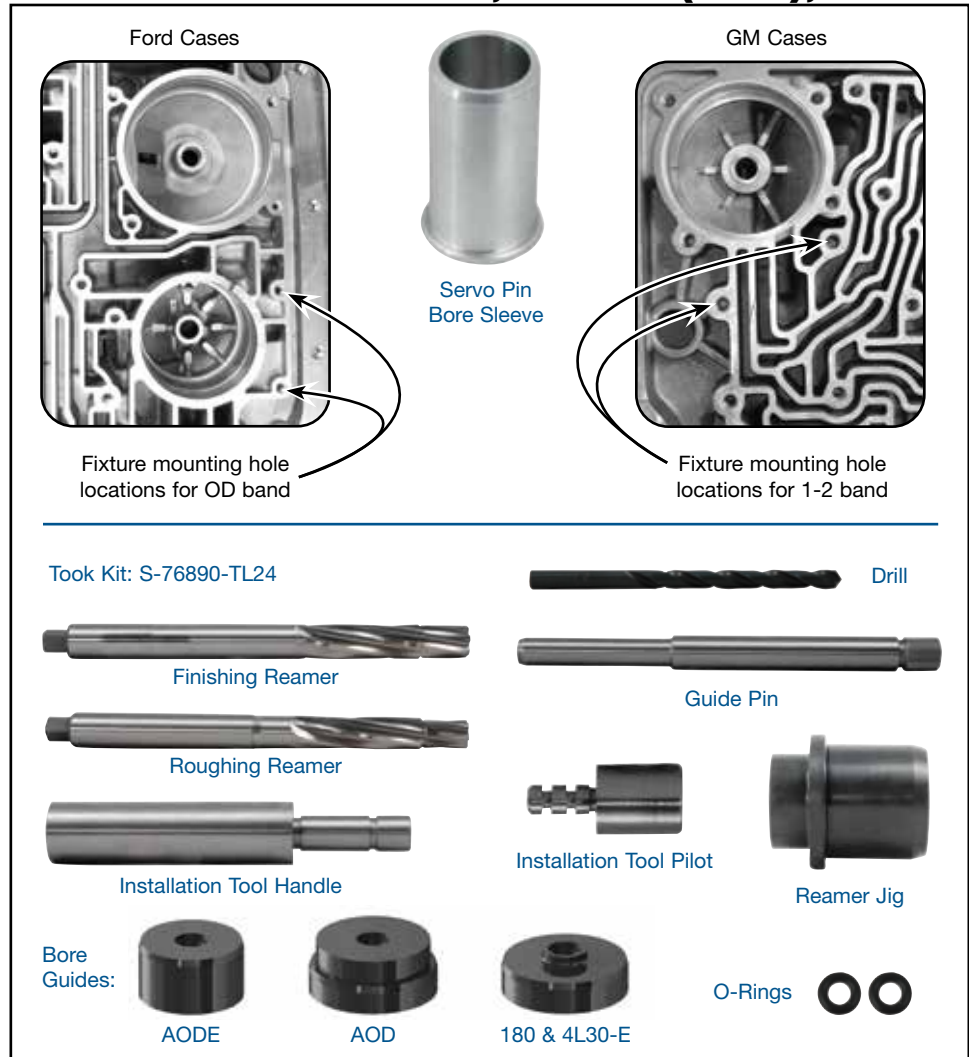

1. Disassembly

- Remove servo assembly from case and thoroughly clean the servo pin bore.

NOTE: On the 180/4L30-E applications, remove the park rod from the case so it will not interfere with the reamers or installation tool.

2. Bore Reaming

- Make sure the guide pin fits the pin bore. Remove bore ridges if necessary.
- Support the case horizontally with the open pin bores pointing up. It is important that this reaming process be done vertically. Install the appropriate bore guide into the bore (Figure 1).
- To align the fixture to the servo pin bore, follow the **SERVO-FIX** set-up instructions. From the **S-76890-TL24** tool kit, use the reamer jig and guide pin.

2. Bore Reaming (continued)

NOTE: Once the servo pin bore is aligned with the **SERVO-FIX**, do not disturb or loosen the fixture or guide setting in any way until both reamers have been used and the reaming process is complete. Be sure to use plenty of continuously supplied cutting fluid while reaming the servo pin bore (**Figure 2 & 3**).

- d. Gently insert the self-piloting roughing reamer into the servo pin bore until the cutting tip contacts the bore opening.
- e. Use a speed handle to turn the reamer in the bore. The reaming action should be clockwise in a smooth and continuous motion at 60-120 rpm.
- f. Continue reaming until the reamer cuts completely through the bore. Remove the roughing reamer. Using low air pressure, blow away chips. Insert the finishing reamer into the reamer jig and follow the steps above. Remove the reamer, then the reamer jig and finally the fixture. Clean the reamer and servo bore with low air pressure and solvent.

3. Installation & Assembly

NOTE: Although the sleeve is designed as a press-fit, use of Loctite® is highly recommended to aid in proper sleeve retention (**Figure 4**).

- a. Remove the pilot from the installation tool by pulling gently.
- b. Slide the sleeve over the small end of the installation tool handle, flanged end first.
- c. Gently push the pilot back into the end of the installation tool, securing the sleeve on the tool. O-Ring lubrication should be used to prevent shearing of the O-rings.
- d. Carefully coat the outer half outside diameter of the sleeve with thin Loctite.
- e. Press the sleeve into the bore, small diameter first, by sliding the installation tool pilot into the case bore and then gently pressing/hammering the handle of the installation tool. Press just far enough to seat the sleeve flange against the case bore boss/face.
- f. From the inside of the case, gently pull the pilot off the installation tool and remove.
- g. Remove debris and test-fit servo pin. Bore can be deburred by using the installation tool without the pilot attached if necessary. Verify that the servo pin moves freely in sleeved bore.
- h. Reassemble the servo per OE specifications.

