

Aisin AW TF-60SN, TF-80SC, TF-81SC; Mini 6F21WA; VW/Audi 09G, 09K, 09M

Oversized Two-Spool Relay/Signal Valve Kit



Part No.

15741-49K

- Valve
- End Plug

NOTE: This kit can be used in any of nine locations in five different valve body applications. See chart **Figure 1** and identification photos **Figures 2, 3 & 4** for details.

Tool Kit



Part No.

F-33741B-TL1

- Reamer
- Reamer Jig
- Guide Pin

NOTE: Sonnax “F-Tool” kits designed to service a specific bore require the VB-FIX, a self-aligning valve body reaming fixture. More information and instructions can be found online at www.sonnax.com.

This tool kit also can be used with Sonnax kits **15741-50K** and **33741B-01**.

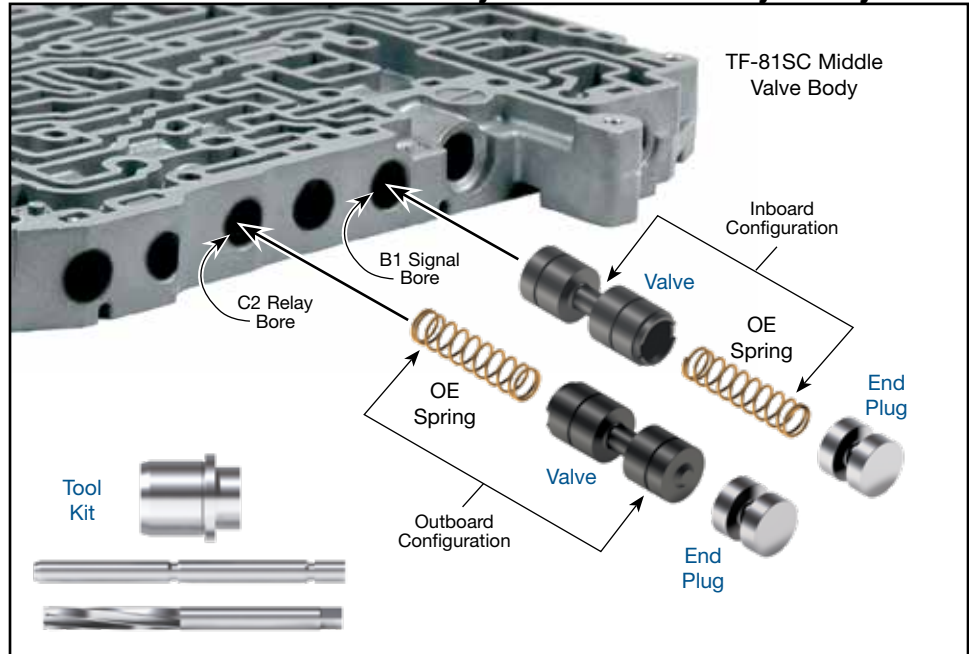

Two-Spool Relay/Signal Valve Chart

Figure 1

Application	Valve Body Section	Valve Name	Spring Install Orientation	Affected Gears
TF-60SN (VW 09G) 6F21WA	Middle Valve Body	K1 Relay*	Inboard	1st, 2nd, 3rd & 4th
		K2 Relay	Inboard	4th, 5th & 6th
	Upper Valve Body #1	B1 Relay	Inboard	2nd & 6th
TF-80SC	Main Accumulator Casting	C1 Relay	Inboard	1st, 2nd, 3rd & 4th
		B1 Signal**	Outboard	2nd & 6th
		C2 Relay	Outboard	4th, 5th & 6th
TF-81SC	Rear Cover	C1 Relay	Inboard	1st, 2nd, 3rd & 4th
	Middle Valve Body	C2 Relay	Inboard	4th, 5th & 6th
		B1 Signal	Outboard	2nd & 6th

* TF-60SN, K1 Relay Location: Use oversized end plug in Sonnax kit. OE end plug has long outboard spool, Sonnax does not duplicate this feature.

** TF-80SC, B1 Signal Location: Discard the oversized end plug in Sonnax kit. Use OE cover plates and screws to retain the valve train.

1. Valve Bore ID

Locate and positively identify the valve body bore that needs repair.

NOTE: See chart **Figure 1** and photo identifications **Figures 2, 3 & 4** for important information on applications, bore locations, installation orientations and affected gears.

TF-80SC Valve Body • Two-Spool Relay/Signal Valve Locations

Figure 2

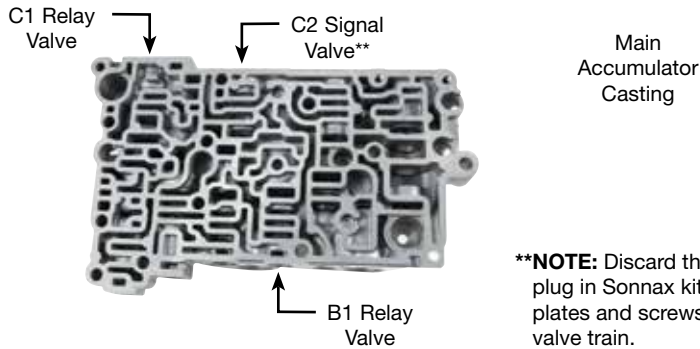

TF-60SN Valve Body

Figure 4

Two-Spool Relay Valve Locations

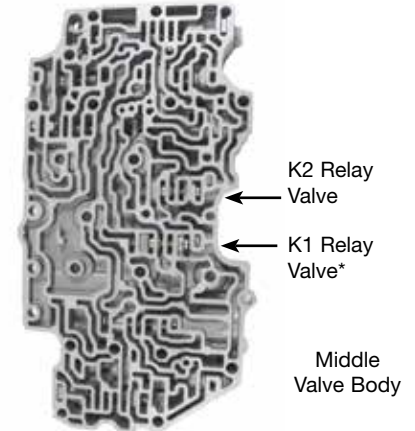

***NOTE:** Use oversized end plug in Sonnax kit. OE end plug has long outboard spool, Sonnax does not duplicate this feature.

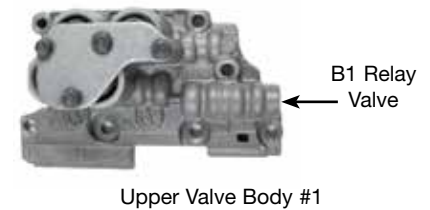

TF-81SC Valve Body • Two-Spool Relay/Signal Valve Locations

Figure 3

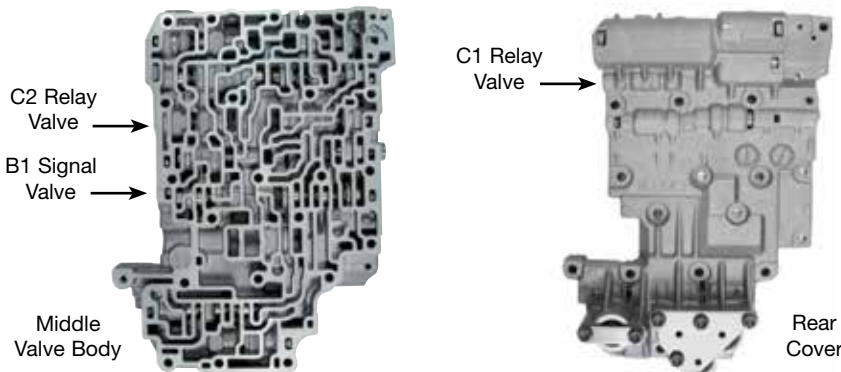

2. Disassembly

- Remove OE valve train, saving OE spring and end plug retainer (if present) for reuse.
- Discard OE valve and end plug.

3. Bore Reaming

Ream desired bore (for reaming instructions/reamer care, please visit www.sonnax.com). Sonnax reaming tool kit F-33741B-TL1 and VB-FIX are required for this operation.

4. Installation & Assembly

- Ensure all debris has been removed from the valve bore and body.
 - Consult chart (Figure 1) to determine installed orientation of Sonnax valve.
 - If spring orientation is listed as "Inboard," install OE spring into the bore first, followed by Sonnax valve with spring pocket end of the valve leading into bore.
 - If spring orientation is listed as "Outboard," install Sonnax valve first with spring pocket outboard, then install OE spring.
- Ensure spring sits into valve spring pocket and doesn't catch on edge of valve adjacent to spring pocket.

- Install Sonnax end plug.

NOTE: See Figures 1 & 2 on how to secure B1 signal location.

- Reinstall OE end plug retainer to secure Sonnax end plug.

5. Final Testing

Vacuum testing at the port(s) indicated holds the recommended minimum 16 in.-Hg.

