

## Oversized Secondary Pressure Regulator Valve Kit



Part No.

**97741-17K**

- Valve
- End Plug
- O-Rings (2) 1 Extra

**NOTE:** Type 1 (8931 casting code).

## Tool Kit



Part No.

**F-39741-TL11**

- Reamer
- Reamer Jig
- Guide Pin

**NOTE:** Sonnax “F-Tool” kits designed to service a specific bore require the VB-FIX, a self-aligning valve body reaming fixture. More information and instructions can be found online at [www.sonnax.com](http://www.sonnax.com).

This tool kit also can be used for Aisin AW TF-80SC secondary regulator valve kit **39741-11K**.

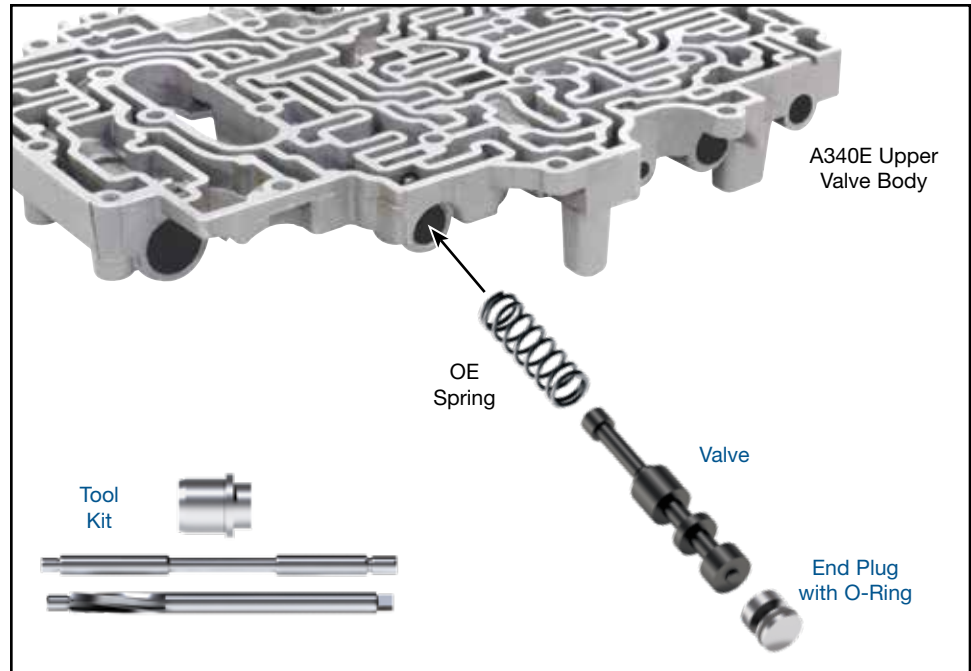
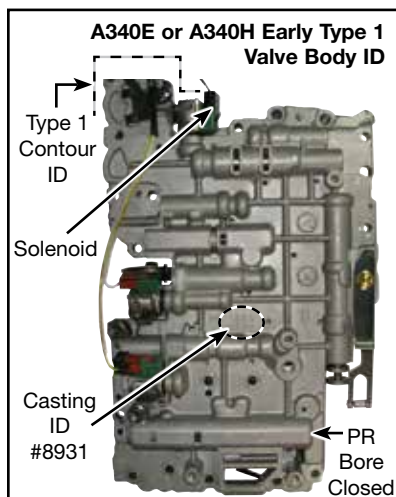

### 1. Disassembly

- Remove and discard OE secondary pressure regulator valve and end plug.
- Retain OE spring for reuse.

### 2. Bore Reaming

Ream secondary pressure regulator bore (for reaming instructions/reamer care, please visit [www.sonnax.com](http://www.sonnax.com)). Sonnax reaming tool kit **F-39741-TL11** and **VB-FIX** are required for this operation.

### 3. Installation & Assembly

- Ensure all debris has been removed from the valve bore and valve body.
- Place OE spring onto Sonnax valve. Install the assembly into the bore, spring end first.
- Place Sonnax O-ring into the shallow Sonnax end plug groove. Lubricate with Sonnax Slippery Stick **O-LUBE** or equivalent and roll the O-ringed end plug on the bench to size.
- Carefully install Sonnax O-ringed end plug into the bore, with the O-ringed land outboard.
- Retain with OE retaining pin.

### 4. Final Testing

Vacuum testing at the port(s) indicated holds the recommended minimum 18 in.-Hg.

