

Toyota/Lexus A750E, A750F, A760E, A760F, A760H, A761E, A960E, A960F, AB60E, AB60F ZIP KIT®

PART NUMBER **A750E-A761E-ZIP**

QUICK GUIDE

Parts are labeled here in order of installation. See other side of sheet for details on kit contents.



CAUTION! Step 5 must confirm OE application and sleeve size first. See notes on page 2.

INSTALLATION DIAGRAM

Note: A761 Valve Body Shown. A750E/F Valve Bodies Vary.



* A760E/F/H, A761E, A960E/F AB60E/F ONLY
** A750E/F ONLY

Upper Valve Body

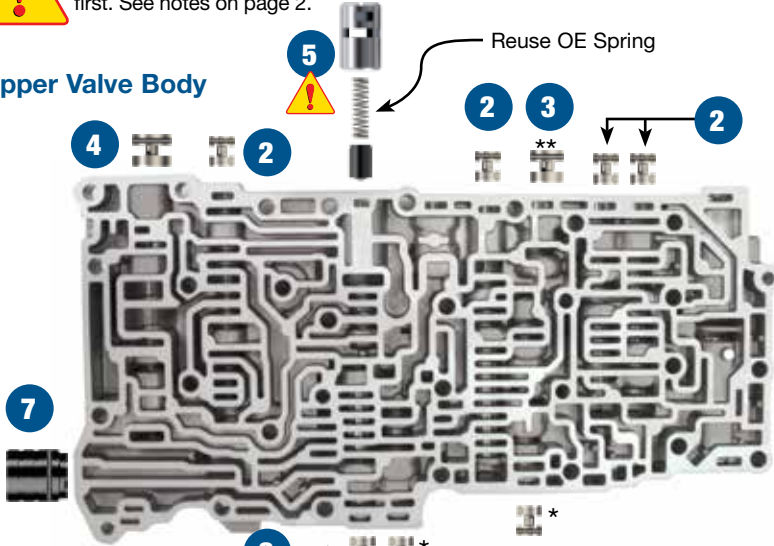

Upper Valve Body #2



CAUTION! Steps 8 & 9: Must note locations of adjustable steps prior to removal. See notes on page 2.



9



CAUTION! Note the location of OE checkballs during disassembly! Location and quantity of checkballs varies depending upon vehicle application!

10

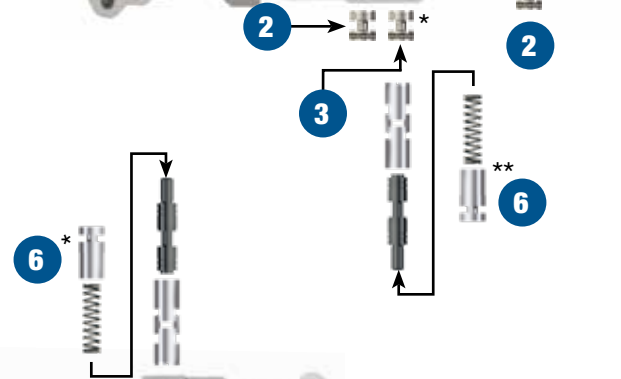

Lower Valve Body #2*

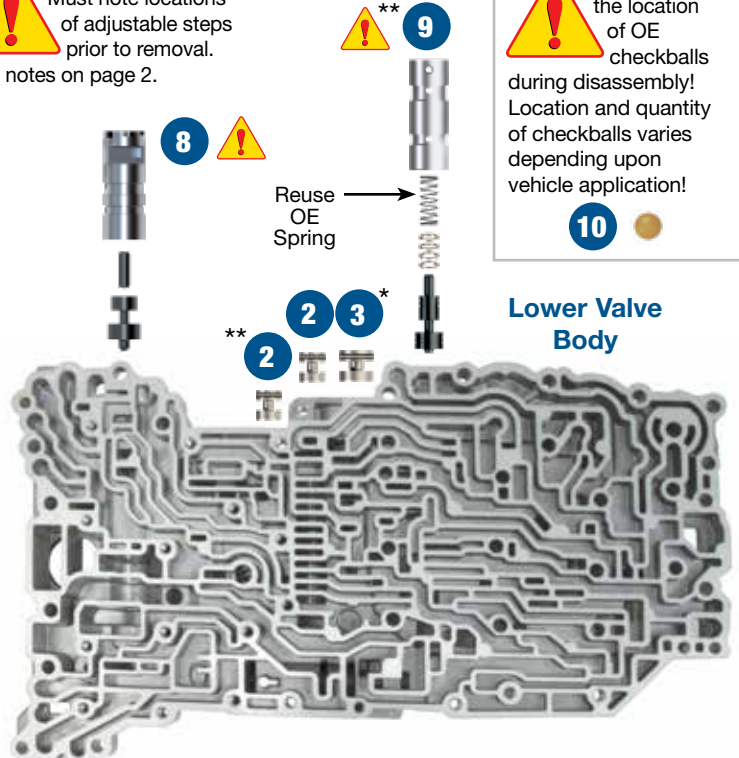
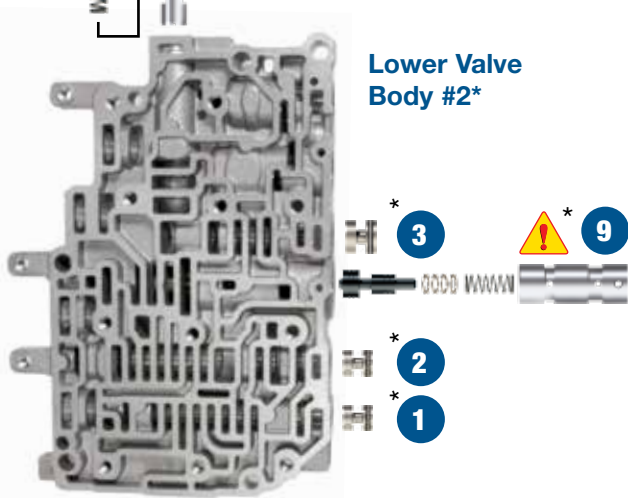

Lower Valve Body

In addition to general rebuilding tips and technical information, the technical booklet included in this kit contains vacuum testing and additional repair options for higher mileage units or for repairing specific complaints which are beyond the scope of this kit.

Kit Contents & Installation Steps

FOR STEPS 1–4: Place O-ring in shallow groove. Install end plugs with O-ring outboard.

Step 1 Replace OE 9mm End Plug

Packaging Pocket 1

- End Plug, 9mm
- O-Rings (2) 1 Extra

Step 2 Replace OE 11mm End Plugs

Packaging Pocket 2

- End Plugs, 11mm (9)
- O-Rings (15) 6 Extra

NOTE: Seven end plugs are used in A750E/F units, while nine end plugs are used in A760E/F/H & A761E, A960E/F.

Step 3 Replace OE 12mm End Plug

Packaging Pocket 3

- End Plugs, 12mm (3)
- O-Rings (4) 1 Extra
- Bolt (1)

NOTE: Bolt used as tool for installation of threaded end plug into bore in lower valve body.

Step 4 Replace OE 14mm End Plug

Packaging Pocket 4

- End Plug, 14mm
- O-Rings (2) 1 Extra

Step 5 Replace OE Lockup Control Plunger Valve & Sleeve

 **NOTE:** Verify OE application and sleeve OD per chart.

For AB60E/F applications, remove valve from .602" dia sleeve and install with .616" dia. sleeve. Reuse OE spring with all applications.

Packaging Pocket 5

- Valve/Sleeve Assembly (.602" dia. sleeve) A750E/F, A761E, A960E/F
- Sleeve (.616" dia.) A760E/F/H, AB60E/F

Step 6 Replace OE Solenoid Modulator Valve Lineup

NOTE: This lineup is in different locations based upon transmission type.

Save OE retainer for reuse. Install Sonnax sleeve/valve assembly with sleeve end face notches inboard and long valve stem outboard. Install Sonnax spring over valve stem. Push the end plug in, stepped end first, fitting the spring into the spring pocket. Secure with OE retainer.

Packaging Pocket 6

- Valve
- Sleeve
- Spring
- End Plug

Step 7 Replace OE B1 Accumulator Piston

NOTE: Save OE springs, cap and retainer for reuse. Install piston, O-ringed end first.

Packaging Pocket 7

- Piston
- O-Rings (2) 1 Extra

Step 8 Replace OE Boost Valve Assembly

 **NOTE:** Prior to removal, note the position of the adjustable step on the OE boost sleeve. Reuse OE retainer and make sure it is set at the same step location on the Sonnax boost sleeve.

Packaging Pocket 8

- Sleeve
- Boost Valve
- Reverse Boost Valve

Step 9 Replace OE Accumulator Control Plunger Assembly

NOTE: This lineup is in different locations based upon transmission type.

Packaging Pocket 9

- Plunger Valve
- Shims (4) Selective
- Sleeve

 **NOTE:** Detailed instructions and illustrations on page 8 of installation and testing booklet.

Prior to removal, note the position of the OE retaining pin on the step of the OE castellated plunger sleeve. Save the OE retaining pin and spring (between valve and sleeve bore) for reuse. Refer to chart for shim assembly details.

After correct number of shims are installed over the long stem of Sonnax plunger valve, place OE spring over long stem of Sonnax plunger valve. Install this valve/shim/spring assembly into Sonnax sleeve, spring end first. Push assembly into bore and secure with OE retaining pin.

OE Sleeve Notch Pin Location	Install This Many Shims
Deepest	0
2nd Deepest	1
Middle	2
2nd Shallowest	3
Shallowest	4

Step 10 Replace OE Checkballs

 **NOTE:** For best results, note location of OE checkballs prior to valve body disassembly. Checkball quantities and locations vary with specific valve body applications.

Packaging Pocket 10

- Checkballs, .218" dia. (20)

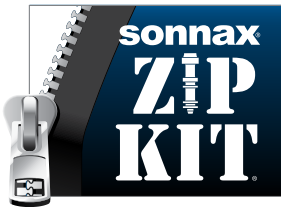

Toyota/Lexus A750E, A750F, A760E, A760F, A760H, A761E, A960E, A960F, AB60E, AB60F ZIP KIT®

PART NUMBER **A750E-A761E-ZIP**

INSTALLATION & TESTING BOOKLET

A750 Series 5-Speed, 7 Solenoids

A760 Series 6-Speed, 9 Solenoids

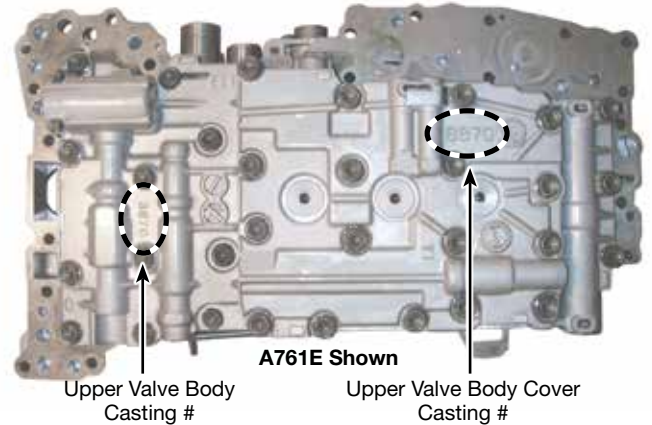
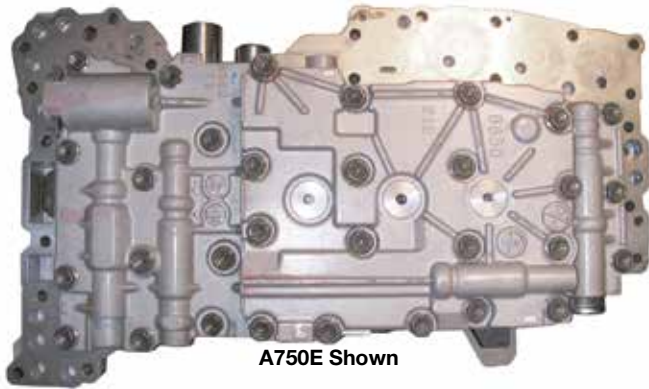

↑ Upper Valve Body ↑

*Solenoid size, connector color and orientation can vary.

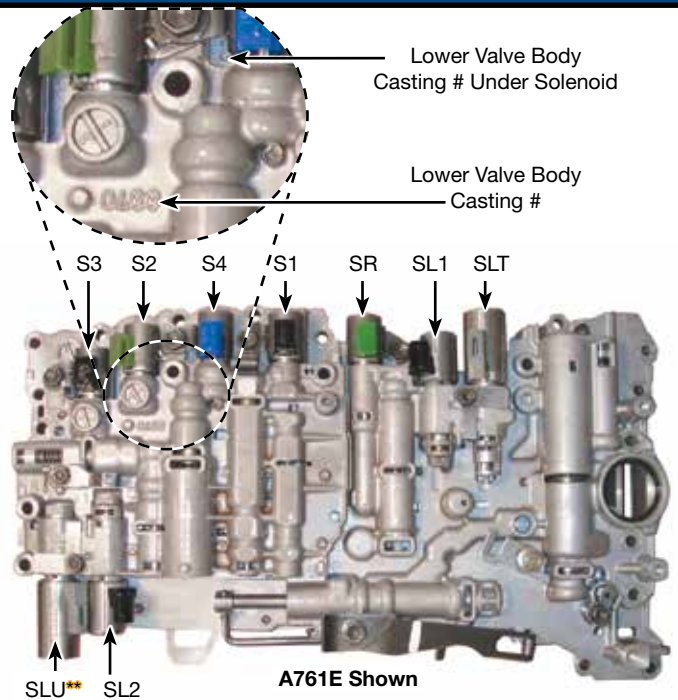
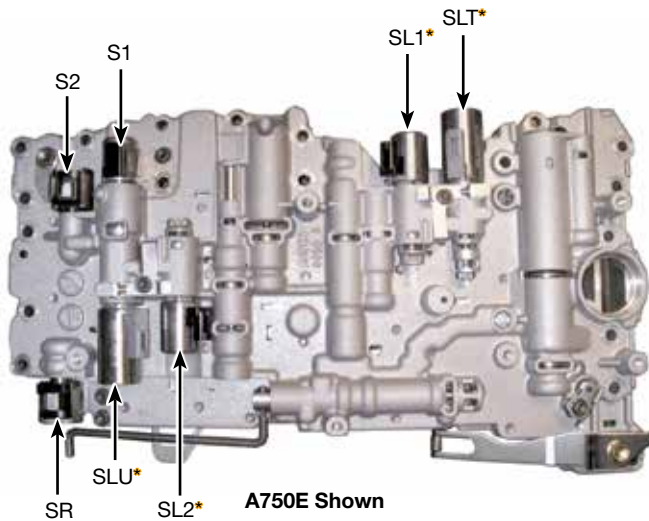

↑ Lower Valve Body ↑

A761E, A960E, A760 & AB60E Valve Body ID

All of the solenoid ID and locations are the same. The only easy way to tell these units apart is the casting numbers.



Proper identification of this valve body is critical!

****NOTE:** For a quick identification the SLU connector is Blue on these models.

Valve Body Type	Large Lower Casting #	Large Upper Casting #	Small Lower Casting #	Small Upper Casting #	Small Lower Plate Code	Small Upper Plate Code	Large Plate Code
A760**	89030	89060	89010	89020	F04	F09	F12
A761	8870	8870	8870	8870	F02	F03	F04
A960	8840	8840	8840	8840	S03	S02	S03
AB60**	89030	89060	89010	89020	F04	L01	L01

Bolt Locations & Torque Specifications

Valve Body Disassembly Bolts		
Bolt Color Code		Bolt Length
A	Pink	20mm
B	Teal	25mm
C	Orange	32mm
D	White	40mm
E	Yellow	45/50mm
F	Black	60mm
G	Olive	64mm
H	Gray	76mm
Torque to 57 in-lb		

Valve Body to Case Bolts		
Bolt Color Code		Bolt Length
1	Red	25mm
2	Green	36mm
3	Blue	45mm
4	Brown	50mm
Torque to 8 ft-lb		

Oil Filter Bolts		
Bolt Color Code		Bolt Length
7	Purple	Various
Torque to 7 ft-lb		

Solenoid Bolts		
Bolt Color Code		Bolt Length
5	Lt. Blue	11.5mm
Torque above to 57 in-lb		
6	Peach	12mm
Torque above to 7 ft-lb		

Reset Memory

The Engine Control Module (ECM) in these transmissions adapts to the conditions of the engine and transmission assemblies. When replacing the engine, transmission, valve body or the ECM you must reset the memory so that the ECM can adapt to new conditions.

Follow OE procedures to reset the memory. Afterwards, follow the OE road test procedures.

Flex Lockup Clutch Control

The ECM regulates the SLU solenoid to provide an intermediate mode between the On/Off operation of the converter clutch in the low-to-mid-speed range. This is for improved fuel economy. Lockup control is prohibited if the brake is depressed, the accelerator pedal is released or engine coolant temperature is below 140°F.

A750 Series Valve Bodies

(A750E shown)

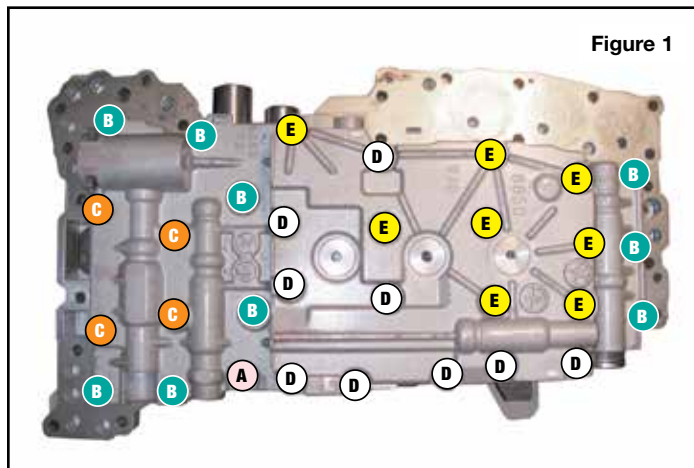

Upper Valve Body, **Valve Body Disassembly** - Bolt Locations

A760 & A960 Series Valve Bodies

(A761E shown)

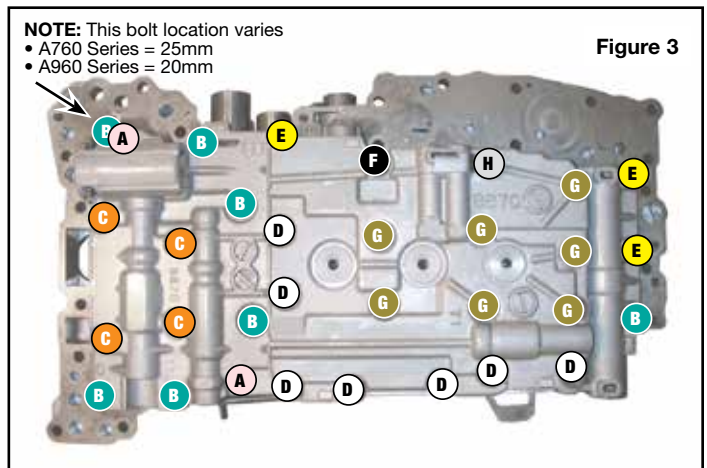

Upper Valve Body, **Valve Body Disassembly** - Bolt Locations

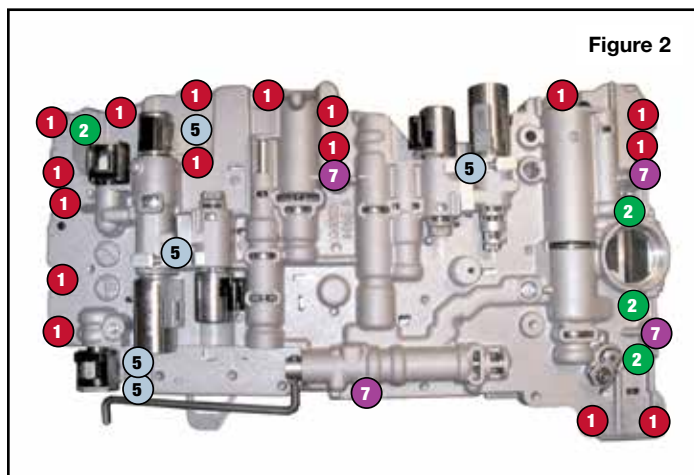

Lower Valve Body, **Case Removal** - Bolt Locations

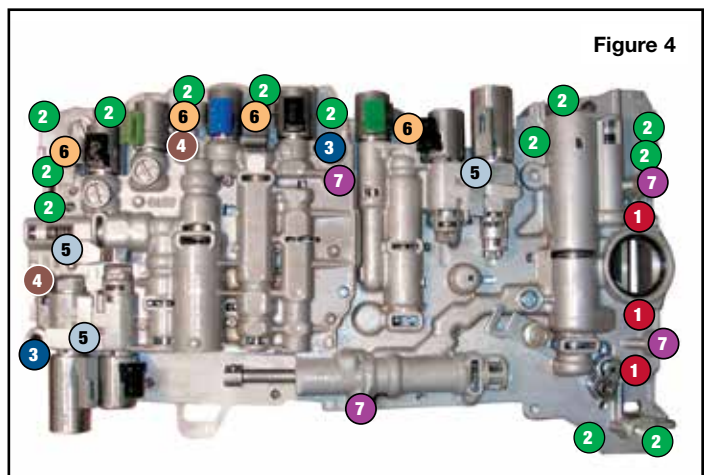

Lower Valve Body, **Case Removal** - Bolt Locations

A750E/F Component & Solenoid Apply

Figure 5 Solenoids Figure 6

Selector Position	Solenoid Valve						Clutch			Brake				One-Way Clutch		
	S1	S2	SR	SL1	SL2	SLU	C1	C2	C3	B1	B2	B3	B4	F1	F2	F3
P-Park	ON				ON											
R-Reverse*	ON				ON				○	⊗			○	○		
N-Neutral	ON				ON											
Drive S5	1st	ON			ON			○								○
	2nd	ON	ON		ON			○				○		○	○	
	3rd		ON		ON			○	○	●		●		○		
	4th*				ON			○	○	●		●				
	5th*			ON	ON		ON		○	○	○	●				
Drive S4	1st	ON			ON			○								○
	2nd	ON	ON		ON			○				○		○	○	
	3rd		ON		ON			○	○		●		○			
	4th*				ON	ON		○	○	●		●				
Drive S4	1st	ON			ON			○								○
	2nd	ON	ON		ON			○				○		○	○	
	3rd*		ON					○	○	⊗		●		○		
Drive S2	1st	ON			ON			○								○
	2nd*	ON	ON	ON				○			⊗	○		○	○	
S1	1st*	ON						○					⊗			○

Solenoid	Resistance Ohms	
	A750 Series	A760 Series
S1	11-15	11-15
S2	11-15	11-15
SR	11-15	11-15
SL1	6	5.0-5.6
SL2	6	5.0-5.6
SLU	6	5.0-5.6
SLT	6	5.0-5.6
S3	-	11-15
S4	-	11-15
Test all at 68°F		

CHART KEY:
 ○ = In operation.
 ● = Applied but ineffective.
 ⊗ = Operates during engine braking.
 * = Engine braking occurs

A760, A960 & AB60 Series Component & Solenoid Apply

Figure 7

Selector Position	Solenoid Valve								Clutch				Brake				One-Way Clutch				
	S1	S2	S3	S4	SR	SL1	SL2	SLU	C1	C2	C3	C4	B1	B2	B3	B4	F1	F2	F3	F3	
P-Park		ON	ON		ON		ON														
R-Reverse*		ON	ON		ON		ON				○			○			○				
N-Neutral		ON	ON		ON		ON														
Drive S6	1st		ON	ON		ON		ON	○			○							○	○	
	2nd	ON	ON	ON		ON		ON	ON	○		○			○		○	○			○
	3rd	ON		ON		ON		ON	ON	○		○	○		●		○				○
	4th	ON				ON		ON	ON	○	○	●	○		●						○
	5th	ON			ON		ON		ON	●	○	○		○		●					
	6th	ON	ON		ON		ON		ON	●	○			●	○	●					
Drive S5	1st		ON	ON		ON		ON	○			○							○	○	
	2nd	ON	ON	ON		ON		ON	ON	○		○			○		○	○			○
	3rd	ON		ON		ON		ON	ON	○		○	○		●		○				○
	4th	ON				ON		ON	ON	○	○	●	○		●						○
	5th	ON			ON		ON		ON	●	○	○		○		●					
Drive S4	1st		ON	ON		ON		ON	○			○							○	○	
	2nd	ON	ON	ON		ON		ON	ON	○		○			○		○	○			○
	3rd	ON		ON		ON		ON	ON	○		○	○		●		○				○
	4th*	ON				ON		ON	ON	○	○	●	○		●						○
Drive S3	1st		ON	ON		ON		ON	○			○							○	○	
	2nd	ON	ON	ON		ON		ON	ON	○		○			○		○	○			○
	3rd*	ON		ON		ON		ON	○		○	○	○		●						
Drive S2	1st		ON	ON		ON		ON	○			○							○	○	
	2nd*	ON	ON	ON	ON	ON		ON	○			○		○	○						
S1	1st*		ON	ON		ON		○			○										○

Critical Wear Areas & Vacuum Test Locations



Drop-In Zip Valve™ Parts Available

NOTE: OE valves are shown in rest position and should be tested in rest position unless otherwise indicated. Test locations are pointed to with an arrow. Springs are not shown for visual clarity. Low vacuum reading indicates wear and Sonnax parts are noted for replacement.

A750 Series • Lower Valve Body

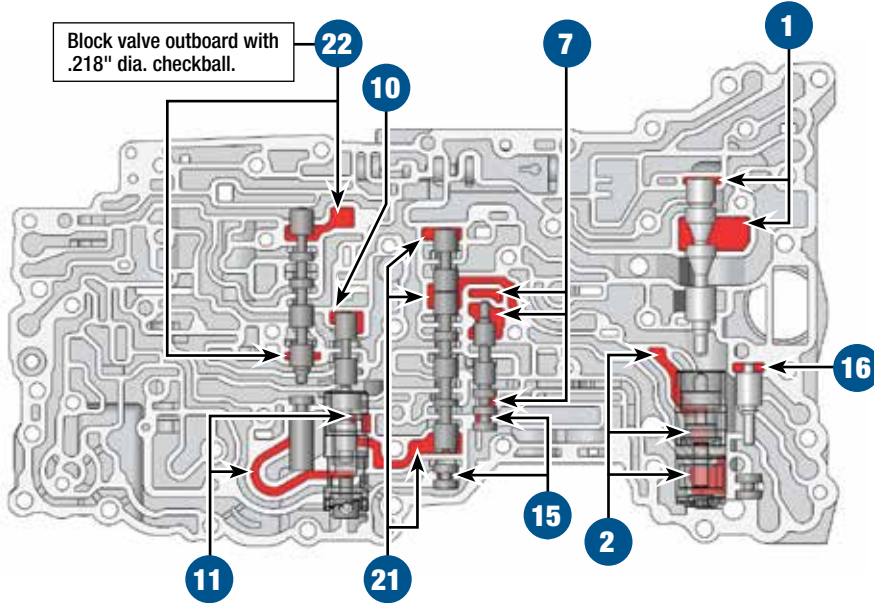

1. Primary Regulator Valve

- Clutch failure • Soft/Harsh shifts
- Low/High line pressure • Low line rise
- High line pressure in Reverse • Overheating

Replace with Sonnax Part No. **147741-04K**
Requires F-147741-TL4 & VB-FIX

2. Boost Assembly

- Clutch failure • Soft/Harsh shifts
- High line pressure in Reverse • Overheating
- Low line rise in Drive • High/Low line pressure

Replace with Sonnax Part No. **147741-01K***

3. Lockup Relay Valve

- TCC apply & release concerns • Shudder
- TCC apply codes • Burnt converter
- Overheating • Lube failures

Replace with Sonnax Part No. **147741-07K**
Requires F-147741-TL7 & VB-FIX

4. Secondary Regulator Valve

- Harsh lockup • TCC apply & release concerns
- Burnt converter • Lube failures

Replace with Sonnax Part No. **147741-10K**
Requires F-147741-TL4 & VB-FIX

5. B1 Accumulator Piston

- Delayed engagement • Flare shifts
- Forward slip • Burnt clutches

Replace with Sonnax Part No. **57917E-19K***

6. Solenoid Modulator Valve

- Solenoid performance codes
- Bang shifts • TCC cycling
- Shift concerns • Bind-up
- Low control pressure • TCC slip

7. Clutch Control Valve

- Gear ratio codes
- Solenoid performance codes
- Harsh upshifts/downshifts
- Flare shifts

8. Lockup Control Valve

- TCC apply & release concerns • TCC codes
- Harsh downshifts • RPM surge on coast

Replace with Sonnax Part No. **147741-16K** A750, A761 & A960 Series
157740-16K A760 & AB60 Series
Requires F-147741-TL16 or F-157740-TL16 & VB-FIX

Upper Valve Body

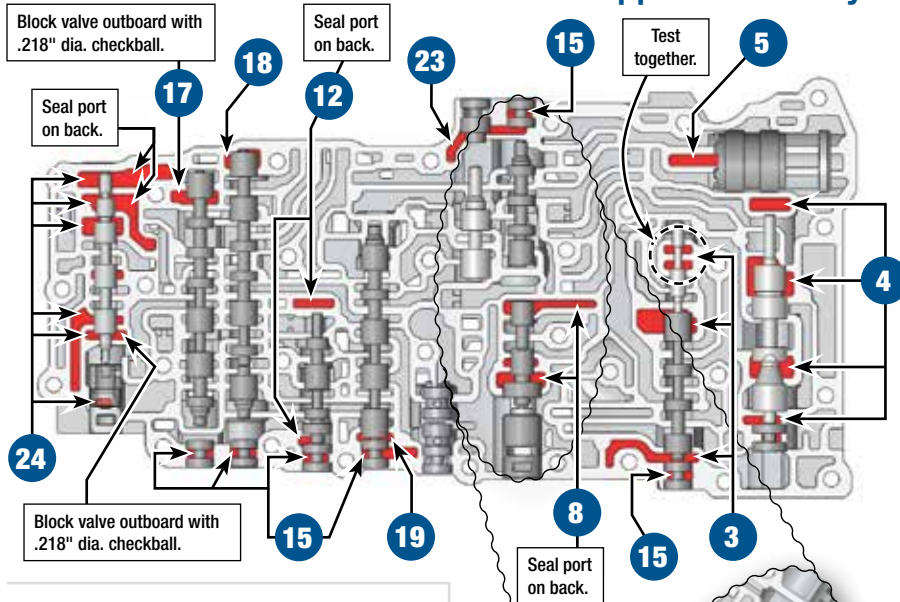

Upper Valve Body No. 2

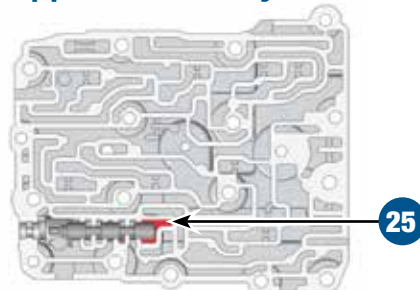

Part numbers with an asterisk () are included in this Zip Kit. Other part numbers are available separately.



For specific vacuum test information, refer to individual part instructions included in kits and available at www.sonnax.com.

9. Lockup Control Plunger Valve & Sleeve

- TCC codes • TCC apply & release concerns
- Harsh downshifts • Cycling TCC RPM

Replace with Sonnax Part No.

147741-37K

A750, A761 & A960 Series

157740-37K

A760 & AB60 Series

10. Accumulator Control Valve

- Harsh shifts • Shift codes • Shift concerns

Replace with Sonnax Part No. **147741-24K**

Requires 147741-TL24

11. Accumulator Control Plunger Valve & Sleeve

- Harsh shifts • Shift codes • Shift concerns

Replace with Sonnax Part No. **147741-43K***

12. Brake Control Valve

- Burnt clutches • Harsh shifts • Flare shifts
- Shift concerns

13. B2 Accumulator Pistons

- 5-6 Harsh/Slip • 3-2 Harsh
- No engine braking in D2

14. & 15. End Plugs

- Various complaints depending on locations of leaking end plug • Pressure loss

14. Replace with Sonnax Part No. 147741-30K

15. Replace with Sonnax Part No. 147741-31K

16. SLT Damper

- Harsh/Soft shifts • Loss of pressure control

17. 1-2 Shift Valve

18. 2-3 Shift Valve

19. 3-4 Shift Valve

20. 4-5 Shift Valve

21. Clutch Apply Control Valve

22. Sequence Valve

23. Clutch Lock Valve

24. B1 Apply Control Valve & Assembly

25. Coast Brake Relay Valve

NOTE: May not have a valve in this location if upper valve body #2 has a casting number of 89010.

26. C3 Apply Relay Valve

- Related shift concerns • Burnt clutches/brakes

A760, A960 & AB60 Series • Lower Valve Body

NOTE: A960 passages are slightly different, however vacuum test locations are the same.

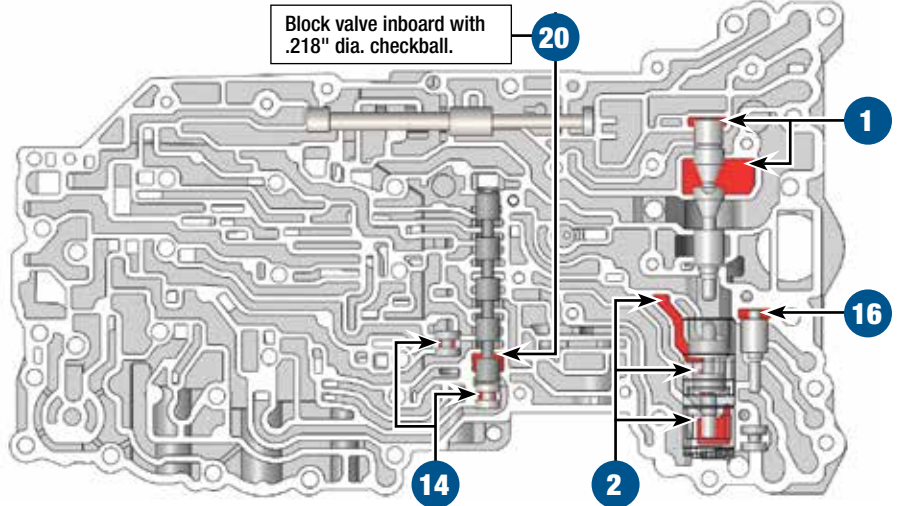

Upper Valve Body

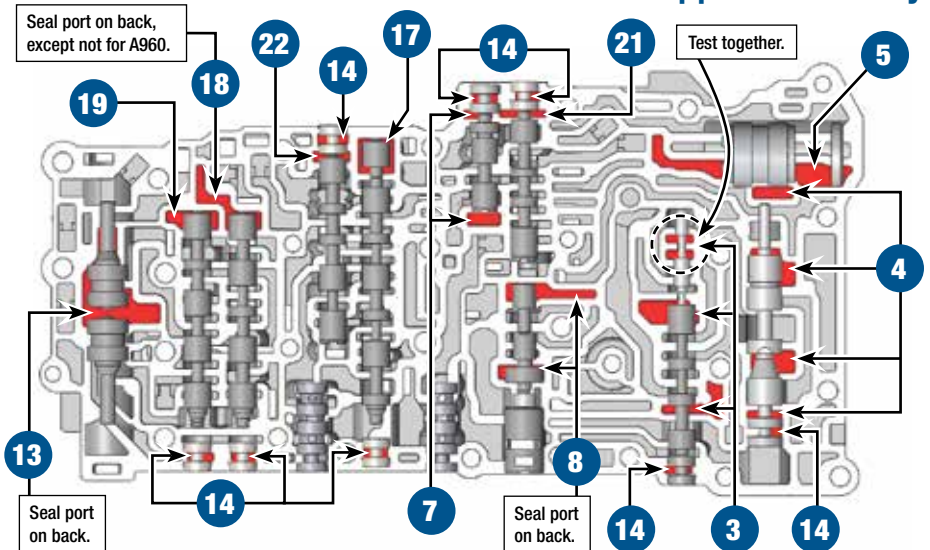

Lower Valve Body No. 2

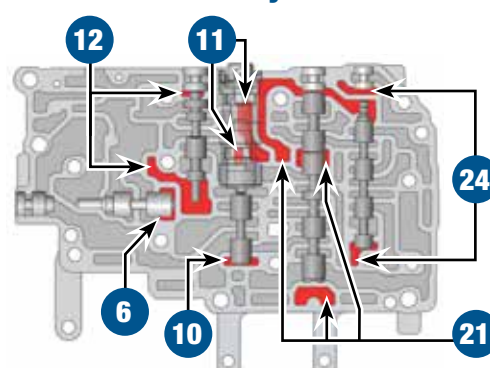

Upper Valve Body No. 2

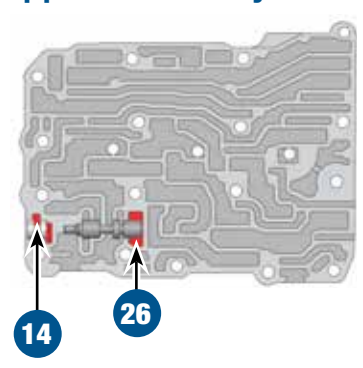

OE Exploded View

A750 Valve Body

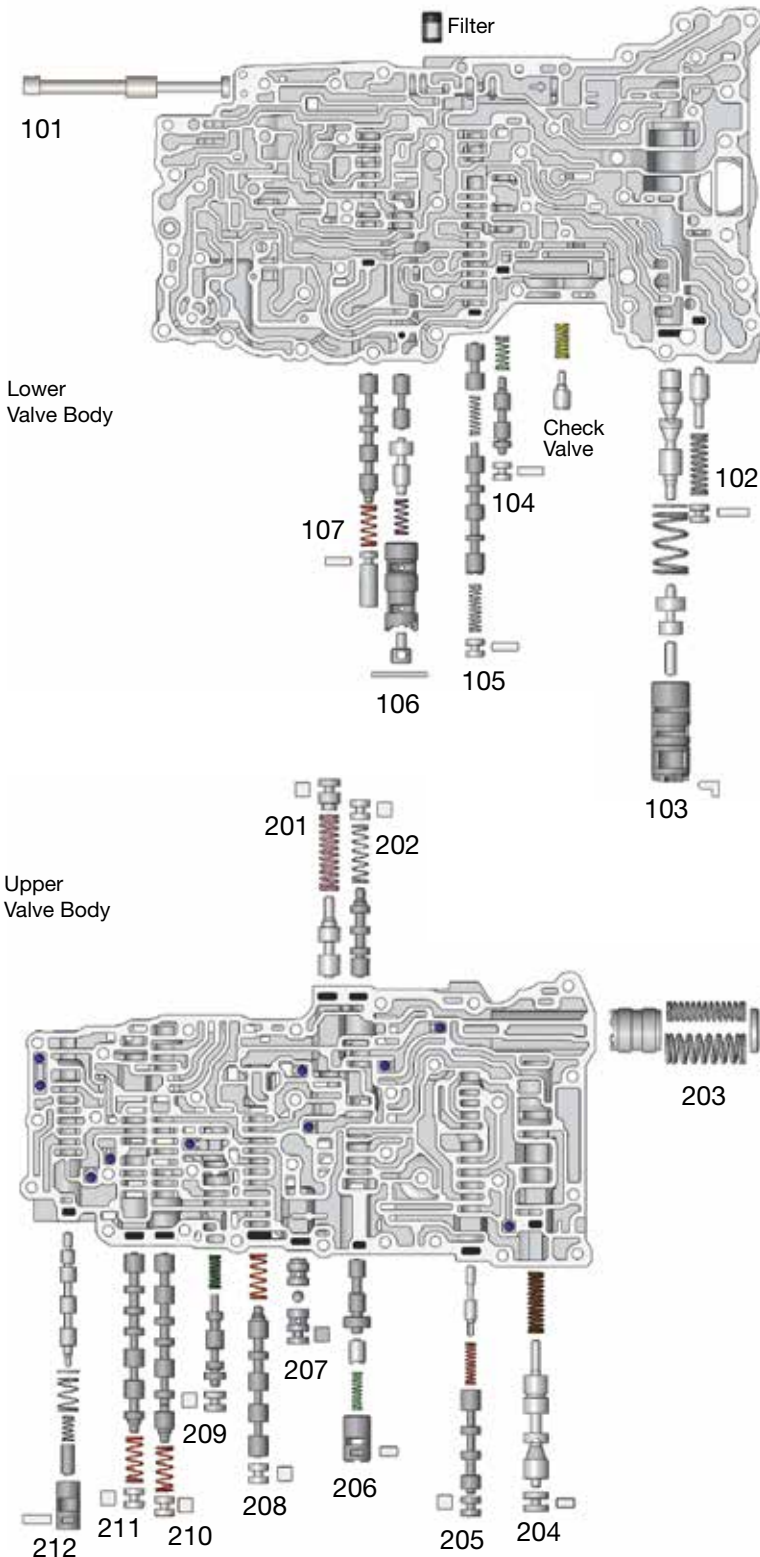

Upper Valve Body No. 2

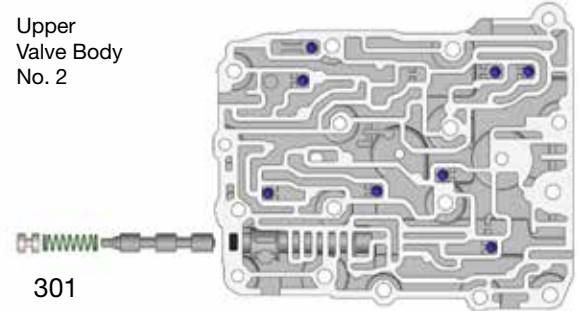

A750 Series Valve Body Descriptions	
I.D. No.	Description
101	Manual Valve
102	SLT Damper
103	Primary Regulator Valve (inboard) Boost Assembly (outboard)
104	Clutch Control Valve
105	Clutch Apply Control Valve
106	Accumulator Control Valve (inboard) Accumulator Control Plunger Valve & Sleeve (outboard)
107	Sequence Valve
201	Solenoid Modulator Valve
202	Clutch Lock Valve
203	B1 Accumulator Piston
204	Secondary Regulator Valve
205	Lockup Relay Valve
206	Lockup Control Valve (inboard) Lockup Control Plunger Valve & Sleeve (outboard)
207	C3 Check Valve
208	3-4 Shift Valve
209	Brake Control Valve
210	2-3 Shift Valve
211	1-2 Shift Valve
212	B1 Apply Control Valve (inboard) B1 Apply Control Plunger Valve & Sleeve (outboard)
301	Coast Brake Relay Valve Note: May not have a valve in this location if the upper cover or upper valve body #2 casting number is 89010.

A760, A960 & AB60 Series Valve Body



NOTE: Checkballs are shown in proper location for A760 series valve bodies. Reference page 8 for proper checkball location in A960 series valve bodies.

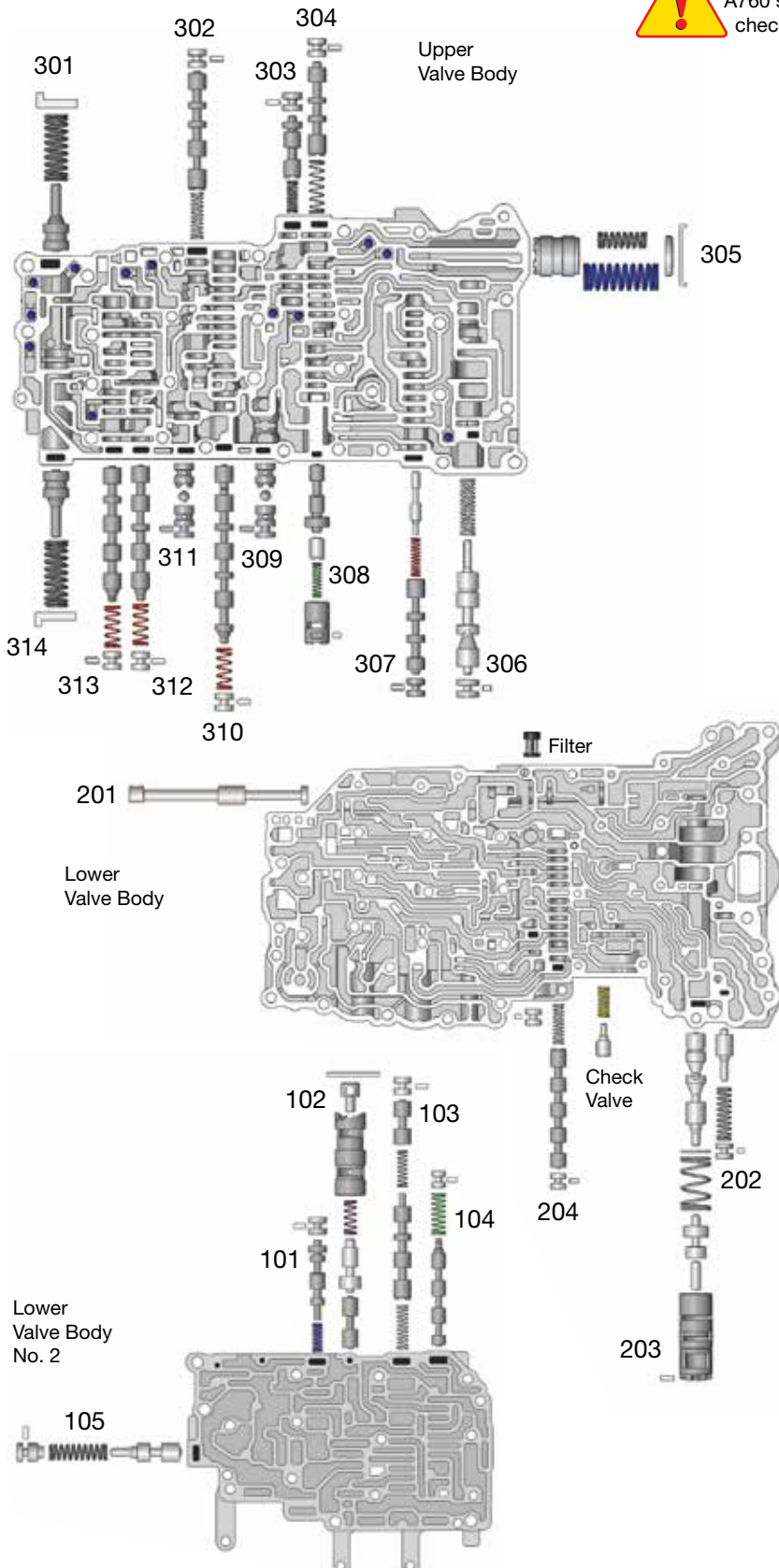

Upper
Valve Body
No. 2

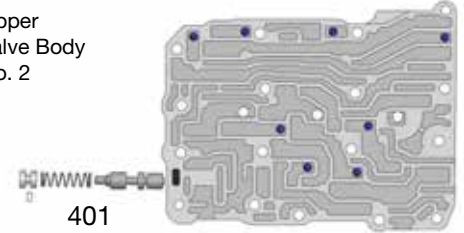

**A760, A960 & AB60 Series
Valve Body Descriptions**

I.D. No.	Description
101	Brake Control Valve
102	Accumulator Control Valve (inboard) Accumulator Control Plunger Valve & Sleeve (outboard)
103	SL1 Relay Valve
104	B1 Apply Relay Valve
105	Solenoid Modulator Valve
201	Manual Valve
202	SLT Damper
203	Primary Regulator Valve (inboard) Boost Valve Assembly (outboard)
204	4-5 Shift Valve
301	B2 Accumulator Piston
302	Reverse Sequence Valve
303	Clutch Control Valve
304	Clutch Apply Relay Valve
305	B1 Accumulator Piston
306	Secondary Regulator Valve
307	Lockup Relay Valve
308	Lockup Control Valve (inboard) Lockup Control Plunger Valve & Sleeve (outboard)
309	C3 Check Valve
310	1-2 Shift Valve
311	B4 Check Valve
312	2-3 Shift Valve
313	3-4 Shift Valve
314	B2 Accumulator Piston
401	C3 Apply Relay Valve

OE Exploded View

A960 Series Valve Body • Proper Check Ball Locations

Upper Valve Body

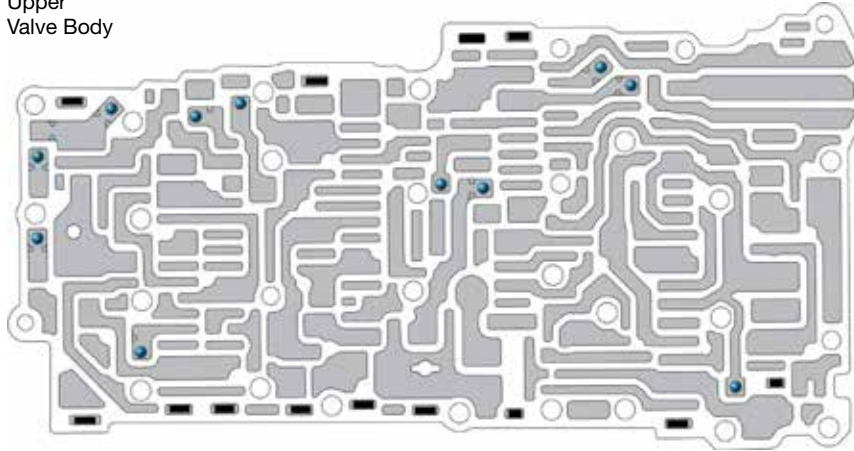

Small Upper Valve Body



Detailed Instructions for Step 9 from Quick Guide

Replace OE Accumulator Control Plunger Valve & Sleeve Assembly

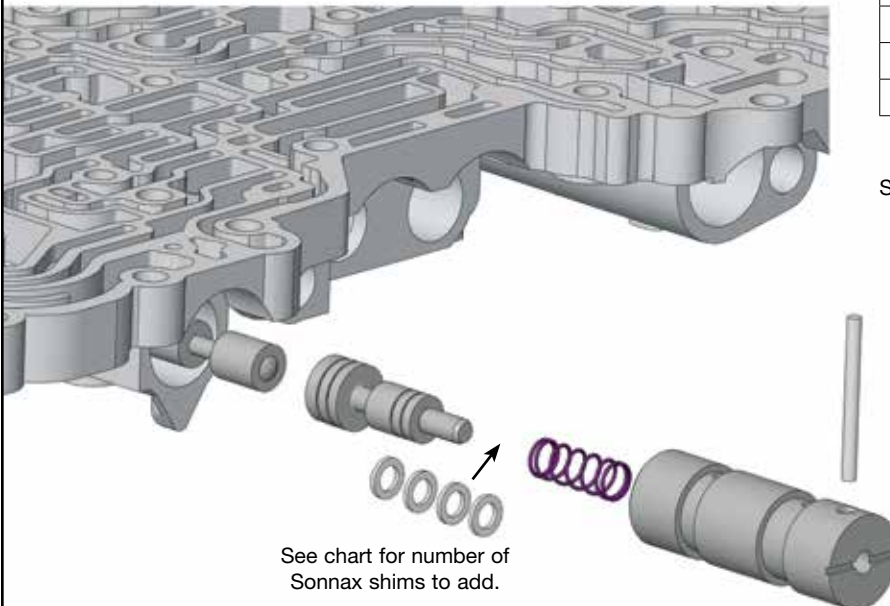

OE Sleeve Notch Location	Use This Many Sonnax Shims
Deepest Notch	0
2nd Deepest Notch	1
Middle Notch	2
2nd Shallowest Notch	3
Shallowest Step	4

Figure 8

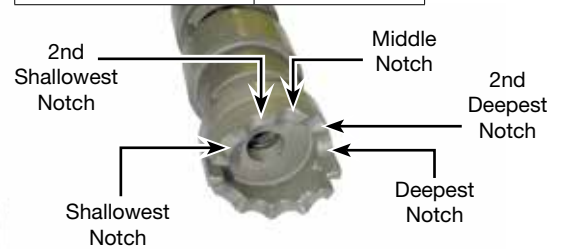

⚠ OE Castellated Plunger Sleeve
Prior to removal, note the position of the OE retaining pin on the adjustable notch!