

### Oversized Lockup Control Valve Kit

**Part No.**  
**47740-30K**



- Control Valve
- Plunger Valve
- Plunger Sleeve

### Tool Kit

**Part No.**  
**F-47740-TL30**



- Reamer
- Reamer Jig
- Guide Pin

**NOTE:** This tool kit can also be used to install oversized lockup control valve kit 47740-31K.

Sonnax "F-Tool" kits designed to service a specific bore require the VB-FIX, a self-aligning valve body reaming fixture. More information and instructions can be found online at [www.sonnax.com](http://www.sonnax.com).

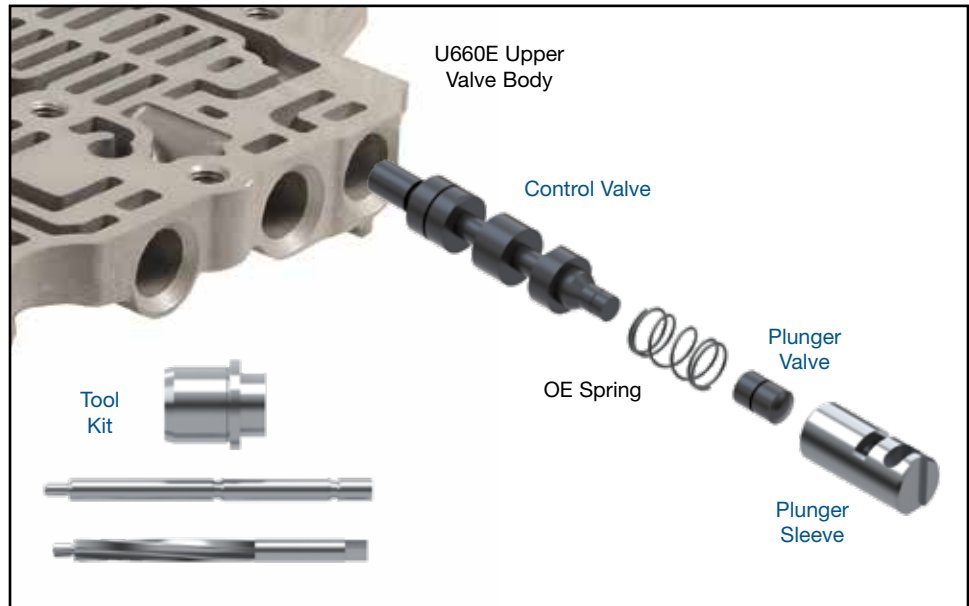

#### 1. Disassembly

- Remove OE retainer and set aside for reuse.
- Remove and discard OE plunger/sleeve assembly and lockup control valve.
- Remove and save OE spring for reuse.

#### 2. Bore Reaming



**NOTE:** Valve body is low-profile and must be secured 1/4" above the VB-FIX base plate in order to establish alignment with the bore. Sonnax adapter plate kit F-85755-TL3PL can be used for this function; pressure plates stacked under the valve body also work well.

If pressure plates are used, the valve body securing clamps **MUST** be placed directly over the plate stack. Clamping on an unsupported area of the valve body or over the bore to be reamed will cause distortion and result in irreparable damage to valve body.

Ream lockup control valve bore (for reaming instructions/reamer care, please visit [www.sonnax.com](http://www.sonnax.com)). Sonnax reaming tool kit F-47740-TL30 and VB-FIX are required for this operation.

#### 3. Installation & Assembly

- Ensure all debris has been removed from valve bore and valve body.
- Install Sonnax lockup control valve with spring stem facing out.
- Install OE spring followed by Sonnax plunger valve/sleeve assembly and OE retainer.

#### 4. Final Testing

Vacuum testing at the port(s) indicated holds the recommended minimum 18 in.-Hg.

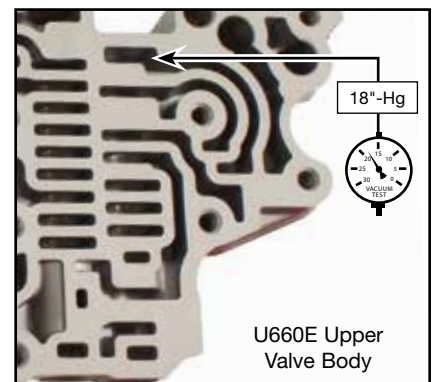

### Oversized Lockup Control Valve Kit

**Part No.**  
**47740-31K**



- Control Valve
- Spring
- Plunger Valve
- Plunger Sleeve

### Tool Kit

**Part No.**  
**F-47740-TL30**



- Reamer
- Reamer Jig
- Guide Pin

**NOTE:** This tool kit can also be used to install oversized lockup control valve kit 47740-30K.

Sonnax "F-Tool" kits designed to service a specific bore require the VB-FIX, a self-aligning valve body reaming fixture. More information and instructions can be found online at [www.sonnax.com](http://www.sonnax.com).

### Toyota/Lexus U760E, U760F

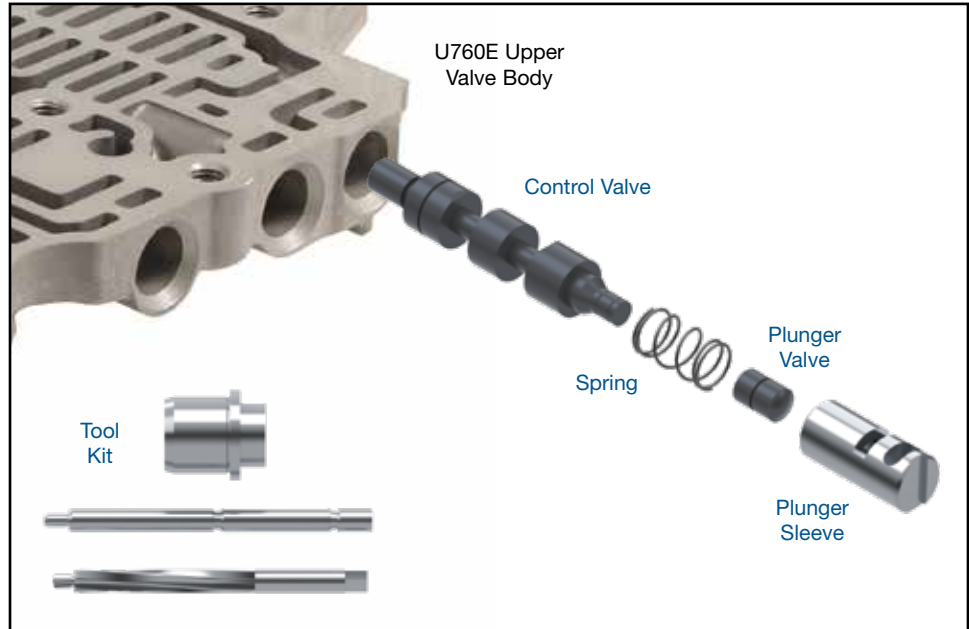

#### 1. Disassembly

- Remove OE retainer and set aside for reuse.
- Remove and discard OE plunger/sleeve assembly, spring, and lockup control valve.

#### 2. Bore Reaming



**NOTE:** Valve body is low-profile and must be secured 1/4" above the VB-FIX base plate in order to establish alignment with the bore. Sonnax adapter plate kit F-85755-TL3PL can be used for this function; pressure plates stacked under the valve body also work well.

If pressure plates are used, the valve body securing clamps **MUST** be placed directly over the plate stack. Clamping on an unsupported area of the valve body or over the bore to be reamed will cause distortion and result in irreparable damage to valve body.

Ream lockup control valve bore (for reaming instructions/reamer care, please visit [www.sonnax.com](http://www.sonnax.com)). Sonnax reaming tool kit F-47740-TL30 and VB-FIX are required for this operation.

#### 3. Installation & Assembly

- Ensure all debris has been removed from valve bore and valve body.
- Install Sonnax lockup control valve with spring stem facing out.
- Install Sonnax spring followed by Sonnax plunger valve/sleeve assembly and OE retainer.

#### 4. Final Testing

Vacuum testing at the port(s) indicated holds the recommended minimum 18 in-Hg.

