

Oversized Pressure Regulator Valve Kit

Part No.
124740-12K



- Valve
- Spring
- End Plug

Tool Kit

Part No.
F-124740-TL12



- Reamer
- Reamer Jig
- Guide Pin

NOTE: Sonnax “F-Tool” kits designed to service a specific bore require the VB-FIX, a self-aligning valve body reaming fixture. More information and instructions can be found online at www.sonnax.com.

Ford 6F50, 6F55; GM 6T70/75 (Gen. 1)

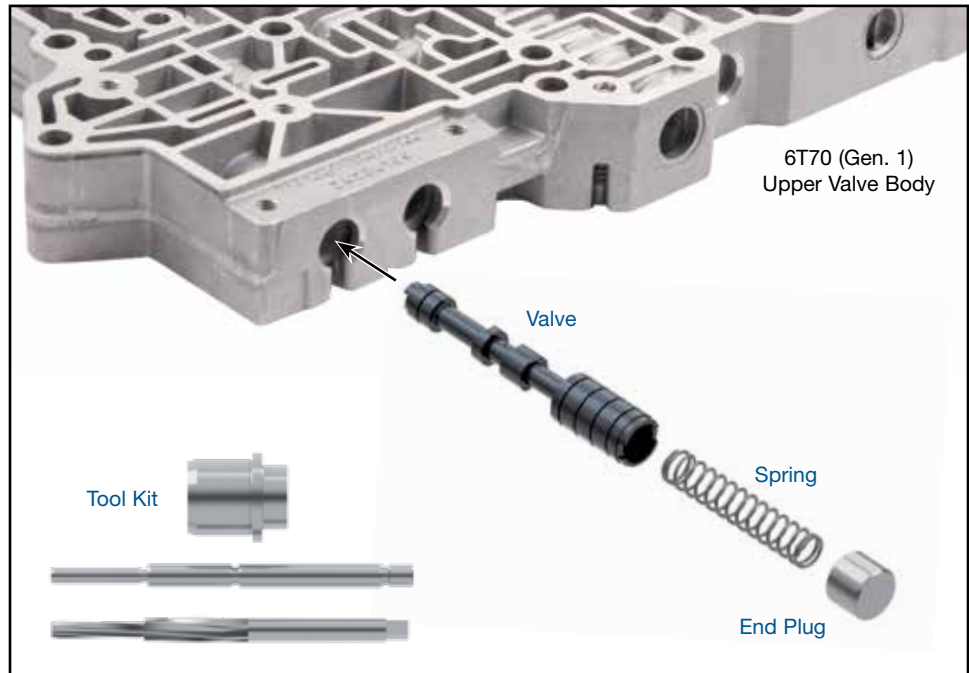

1. Disassembly

- Remove OE retaining clip and set aside for reuse.
- Remove and discard OE end plug, spring and pressure regulator valve.

2. Bore Reaming

Ream pressure regulator bore (for reaming instructions/reamer care, please visit www.sonnax.com). Sonnax reaming tool kit **F-124740-TL12** and **VB-FIX** are required for this operation.

NOTE: Clear chips from reamer and bore often to ensure full ream depth in blind bore.

3. Installation & Assembly

- Be certain all debris has been removed from valve bore and valve body.
- Install Sonnax pressure regulator valve.
- Install Sonnax spring, ensuring it is seated inside pressure regulator valve spring pocket.
- Install Sonnax end plug.
- Reinstall OE retaining clip.

4. Final Testing

Vacuum tests at the ports indicated hold the recommended minimum 14 and 18 in.-Hg.

