

Control Pressure Regulator Valve Kit

Part No.

144740-04K

- Valve
- Sleeve
- Spring

Ford 6F35 (Gen. 1, 2 & 3)

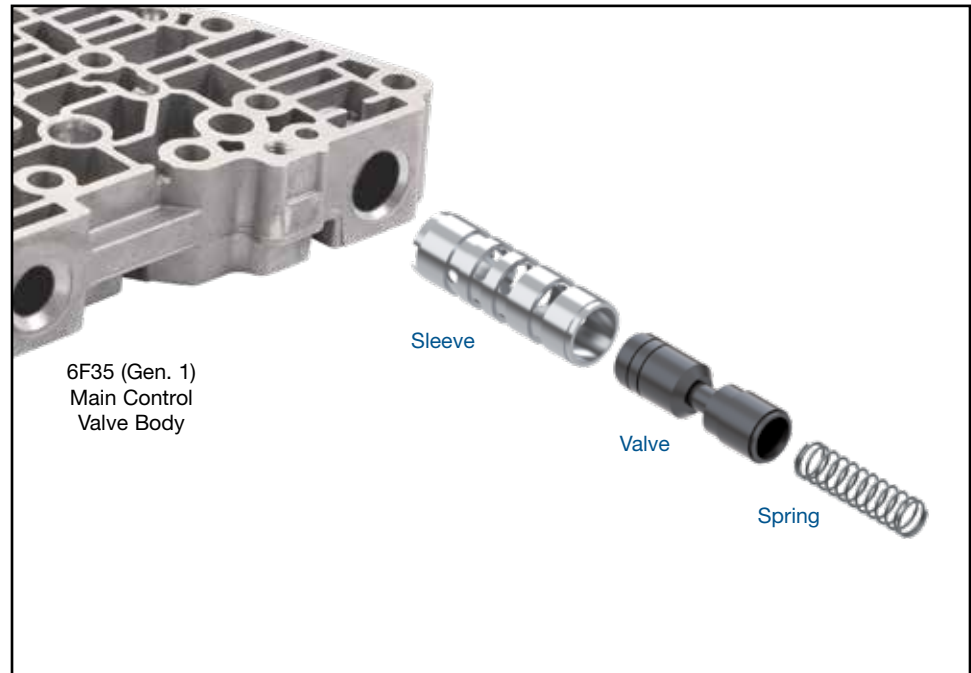

1. Disassembly

- Slide out OE spring retainer plate and set aside for reuse.
- Remove and discard OE spring and control pressure regulator valve.

2. Installation & Assembly

- Clean valve body bore to remove any debris.
- Install Sonnax sleeve, notched end first.
- Install Sonnax valve with spring pocket facing outboard.
- Install Sonnax spring into valve spring pocket.
- Reinstall OE spring retainer plate.

3. Final Testing

Vacuum testing at the port(s) indicated holds the recommended minimum 18 in.-Hg.

