

## Aisin AW TF-60SN, TF-80SC, TF-81SC; Mini 6F21WA; VW/Audi 09G, 09K, 09M

### Oversized C1/K1 Clutch Control Valve Kit



Part No.

**15741-55K**

- Valve
- Springs (2) Selective

**NOTE:** Also fits Volvo (AM6), Opel (AF40), Saab (AF40/6), Ford (AF21) and Mazda (AW6A-EL).

### Tool Kit



Part No.

**F-15741-TL55**

- Reamer
- Reamer Jig
- Guide Pin

**NOTE:** Sonnax “F-Tool” kits designed to service a specific bore require the VB-FIX, a self-aligning valve body reaming fixture. More information and instructions can be found online at [www.sonnax.com](http://www.sonnax.com).

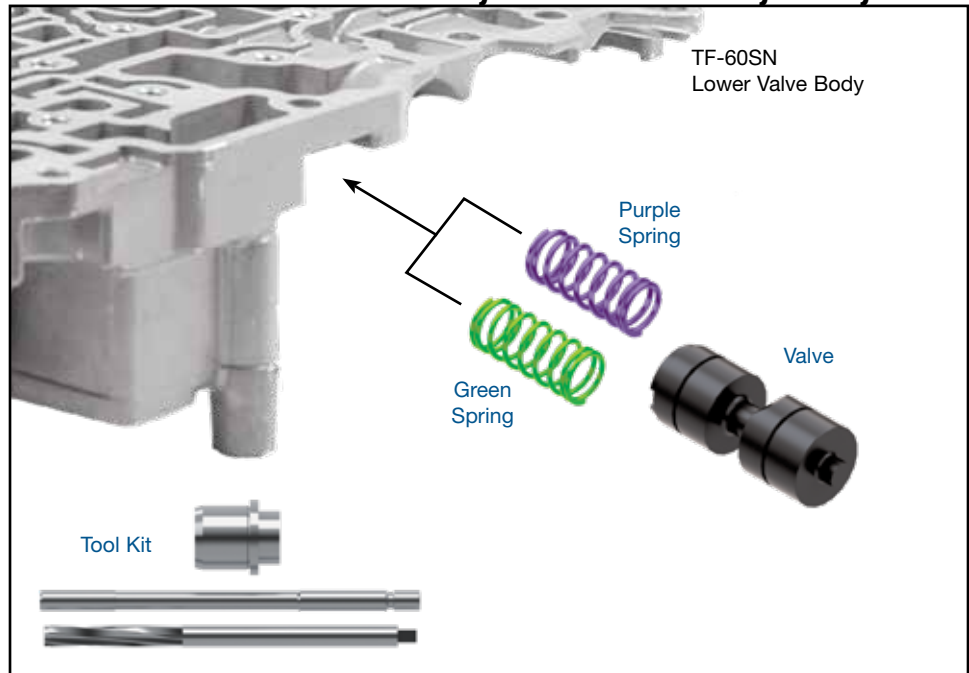

**CAUTION:** Prior to removal of spring adjustment plug, measure and record distance from plug to the casting (**Figure 1**). This dimension must be matched during reassembly.

#### 1. Disassembly

- Remove and save OE adjustment plug retaining clip.
- Measure and record adjustment plug-to-casting distance, then remove and save OE adjustment plug.
- Remove OE retaining pin and solenoid, set aside for reuse.
- Remove and discard OE valve and spring.

#### 2. Bore Reaming

Ream C1/K1 clutch control valve bore (for reaming instructions/reamer care, please visit [www.sonnax.com](http://www.sonnax.com)). Sonnax reaming tool kit **F-15741-TL55** and **VB-FIX** are required for this operation.



### 3. Installation & Assembly

- Ensure all debris has been removed from valve bore and body.
- Reinstall OE spring adjustment plug and set to the reference dimension noted in disassembly procedure, then reinstall OE adjustment plug retaining clip.



**NOTE:** To reduce pressure loss past the spring adjustment plug threads, an ATF-compatible thread sealant can be used. Permatex® 24163 surface prep activator combined with blue threadlocker works well for this purpose. Compound used must not create a permanent set.

- Select correct spring for the application (**Figure 2**). Install Sonnax spring, ensuring spring I.D. goes over spring adjuster nub and spring is secured in spring pocket during installation.
- Reinstall OE solenoid and retaining pin.

### 4. Final Testing

Vacuum tests at the ports indicated hold the recommended minimum 16 in-Hg and 18 in-Hg. (**Figure 3**).

Figure 2

Spring Color	Unit
Purple	TF-60SN, 6F21WA, 09G, 09K, 09M
Green	TF-80SC, TF-81SC (also fits: Volvo AM6, Opel AF40, Saab AF40/6, Ford AF21, Mazda AW6A-EL)

