

Oversized Converter Relief Valve Kit



Part No.
F-74846-08K

- Valve
- Spring

Tool Kit



Part No.
F-74846-TL8

- Reamer
- Reamer Jig
- Guide Pin

NOTE: Sonnax "F-Tool" kits designed to service a specific bore require the VB-FIX, a self-aligning valve body reaming fixture. More information and instructions can be found online at www.sonnax.com.

WARNING: Required tool kit F-74846-TL8 is no longer in production. Check with your distributor for availability.

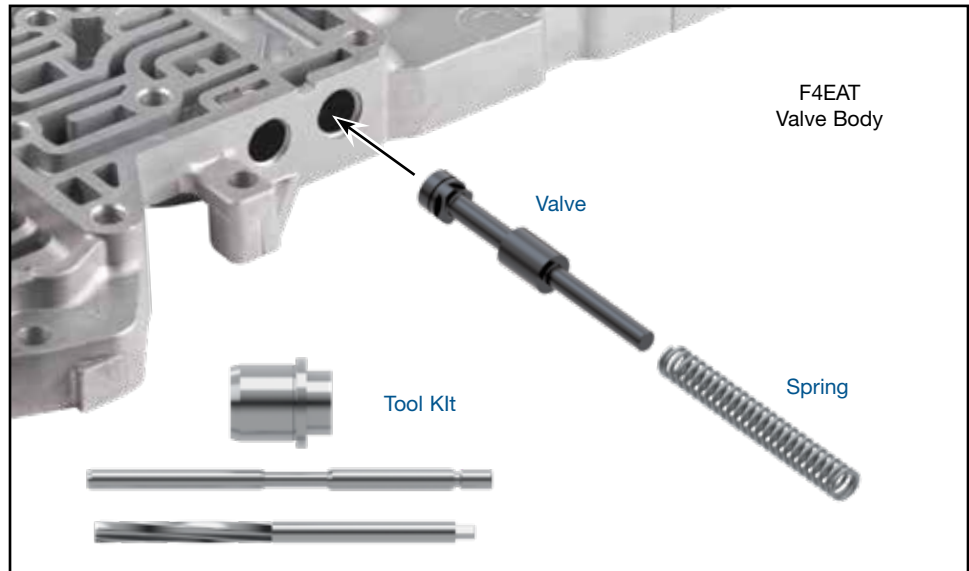

1. Disassembly

- Remove OE retainer clip and set aside for reuse.
- Remove OE converter relief valve and spring and discard.

2. Bore Reaming

WARNING: To ensure correct bore alignment, place casting on VB-FIX with bolt bosses facing upward as shown (**Figure 1**).

Ream converter relief bore (for reaming instructions/reamer care, please visit www.sonnax.com). Sonnax reaming tool kit **F-74846-TL8** and **VB-FIX** are required for this operation.

3. Installation & Assembly

- Ensure all debris has been removed from valve bore and body.
- Install Sonnax converter relief valve.
- Install Sonnax spring and secure with OE retainer clip.

4. Final Testing

Vacuum testing at the port(s) indicated holds the recommended minimum 18 in-Hg (**Figure 2**).

