

Oversized TCC Apply Valve

Part No.
33740-06



Tool Kit

Part No.
F-33740-TL6



- Reamer
- Reamer Jig
- Guide Pin

NOTE: Sonnax "F-Tool" kits designed to service a specific bore require the VB-FIX, a self-aligning valve body reaming fixture. More information and instructions can be found online at www.sonnax.com.

Ford CFT30

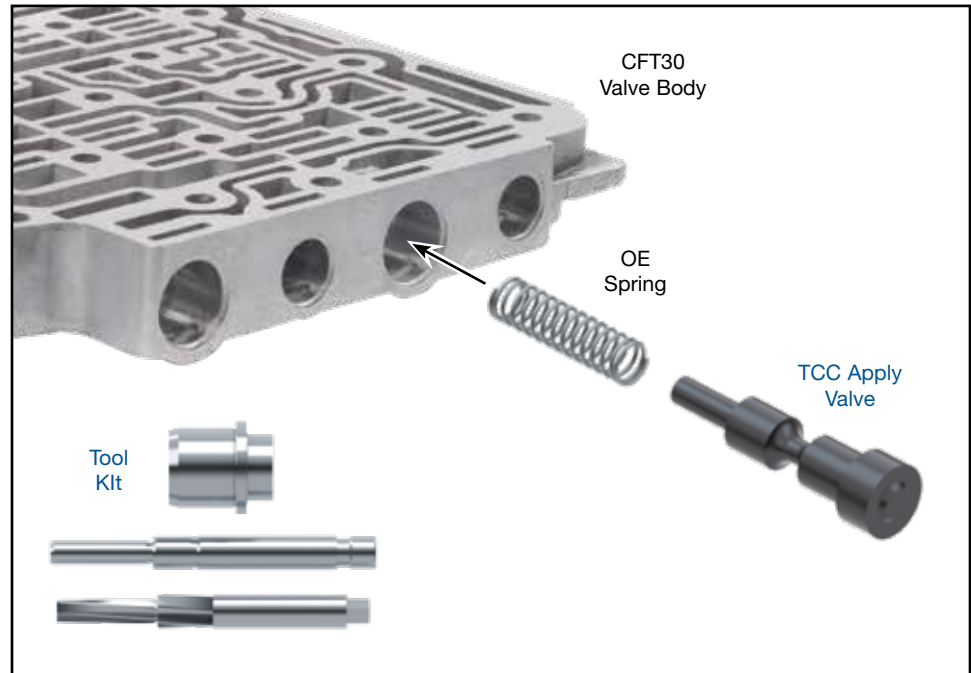

1. Disassembly

- Remove OE retainer and end plug, set aside for reuse.
- Remove and discard OE valve.
- Remove OE spring, set aside for reuse.

2. Bore Reaming

Ream TCC apply bore (for reaming instructions/reamer care, please visit www.sonnax.com). Sonnax reaming tool kit **F-33740-TL6** and **VB-FIX** are required for this operation.

3. Installation & Assembly

- Ensure all debris is cleaned from valve bore and valve body.
- Reinstall OE spring, followed by Sonnax valve.
- Reinstall OE end plug and secure with OE retainer.

4. Final Testing

Vacuum testing at the port(s) indicated holds the recommended minimum 17 in-Hg.

