

Oversized Solenoid Switch Valve & Plug Kit

Part No.

92835-32K

- Valve
- Inner Plug
- Outer Plug
- End Plug
- O-Rings (2) 1 Extra

NOTE: Fits bores containing OE switch valve with .420" dia. large spool only (main photo).



Tool Kit

Part No.

F-92835-TL32

- Reamer
- Reamer Jig
- Guide Pin

NOTE: Sonnax "F-Tool" kits designed to service a specific bore require the VB-FIX, a self-aligning valve body reaming fixture. More information and instructions can be found online at www.sonnax.com.

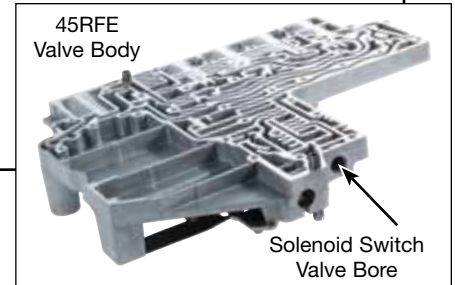
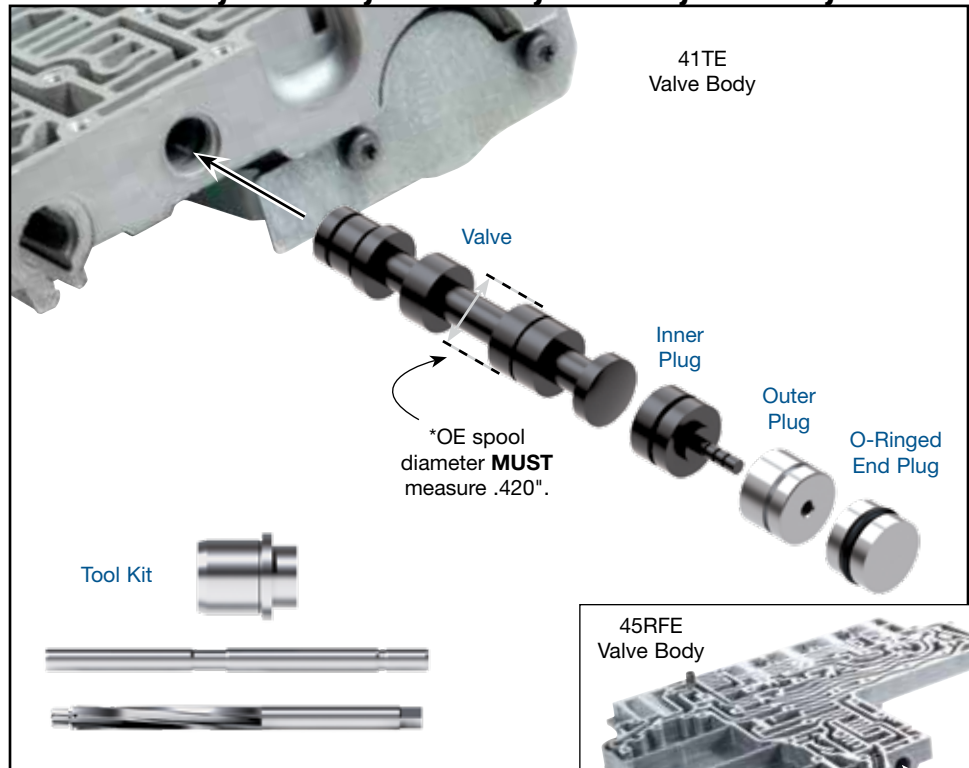

NOTE: Large spool of OE switch valve must be .420" dia. (main photo). If spool measures .420", continue installation. If spool measures .453", **STOP!** This Sonnax kit cannot be used.

Instead, install Sonnax oversized solenoid switch valve & plug kit **92835-31K** after reaming bore with Sonnax tool **F-92835-TL31**.

1. Disassembly

- Remove OE retainer, end plug and switch valve plugs and set aside.
- Remove OE solenoid switch valve and measure large spool. If large spool is .420" dia., proceed to step "c". If spool measures .453", **STOP** and see note above.
- If OE switch valve spool measures .420" dia., discard OE end plug, switch valve plugs and switch valve. Save OE retainer for reuse.

2. Reaming

Ream solenoid switch valve bore (for reaming instructions/reamer care, please visit www.sonnax.com). Sonnax reaming tool kit **F-92835-TL32** and **VB-FIX** are required for this operation.



TECH TIP: These valve bodies commonly warp and allow pressure to escape the switch valve circuit. Recommend flat-sanding the casting to ensure pressure is properly contained.

3. Installation & Assembly

- Ensure all debris has been removed from valve bore and valve body.
- Install Sonnax solenoid switch valve, small diameter first (**main photo**).
- Install Sonnax switch valve plugs. Outer plug has a slight chamfered edge on one side; this side must face outward (**Figure 1**).
- Install Sonnax O-ring into groove of Sonnax end plug. Lubricate O-ringed end plug with Sonnax Slippery Stick **O-LUBE**. Roll on clean bench to size O-ring into groove.
- Insert O-ringed end plug into bore, nub facing inward (**Figure 2**).
- Reinstall OE retainer.

4. Final Testing

Vacuum testing at the port(s) indicated holds the recommended minimum 16 in-Hg (**Figures 3 & 4**).

