

Oversized Working Pressure Regulator Valve

Part No.
88740-01



Tool Kit

Part No.
F-88740-TL



- Reamer
- Reamer Jig
- Guide Pin

NOTE: Sonnax “F-Tool” kits designed to service a specific bore require the VB-FIX, a self-aligning valve body reaming fixture. More information and instructions can be found online at www.sonnax.com.

WARNING! Required tool kit F-88740-TL is no longer in production. Check with your distributor for availability.

Mercedes 722.9

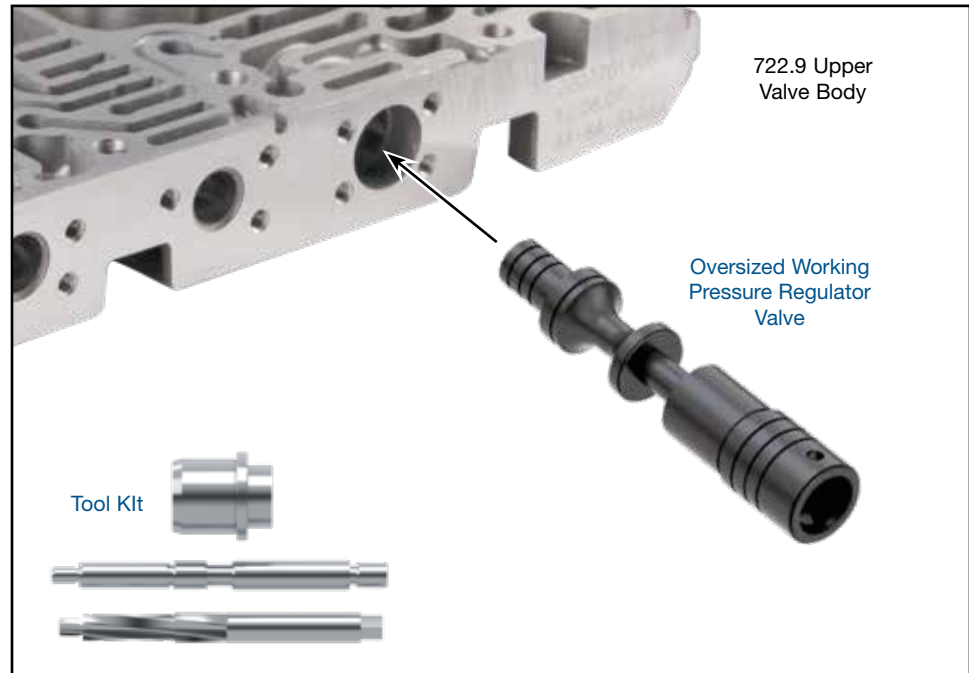

NOTE: Sonnax valve replaces early and late OE valves (Figure 1).

1. Disassembly

- Remove OE retainer plate and save for reuse.
- Remove OE spring and set aside for reuse.
- Remove and discard OE valve.

2. Bore Reaming

Ream working pressure regulator bore (for reaming instructions/reamer care, please visit www.sonnax.com). Sonnax reaming tool kit **F-88740-TL** and **VB-FIX** are required for this operation.

3. Installation & Assembly

- Ensure all debris has been removed from valve bore and body.
- Install Sonnax valve.
- Reinstall OE spring, ensuring it seats in valve spring pocket.
- Reinstall OE retainer plate.

4. Final Testing

Vacuum testing at the port(s) indicated holds the recommended minimum in-Hg (Figure 2).

