

Supported Servo Pin & Cover Kit

Part No.
28821-19K

- Supported Servo Cover
- Cover O-Ring
- Gasket
- Retaining Clip
- Shims (3)
- Pin O-Ring
- Supported Servo Pin
- Bolts (3) not shown
- Plug not shown

Patent No. 10,072,683

GM Powerglide

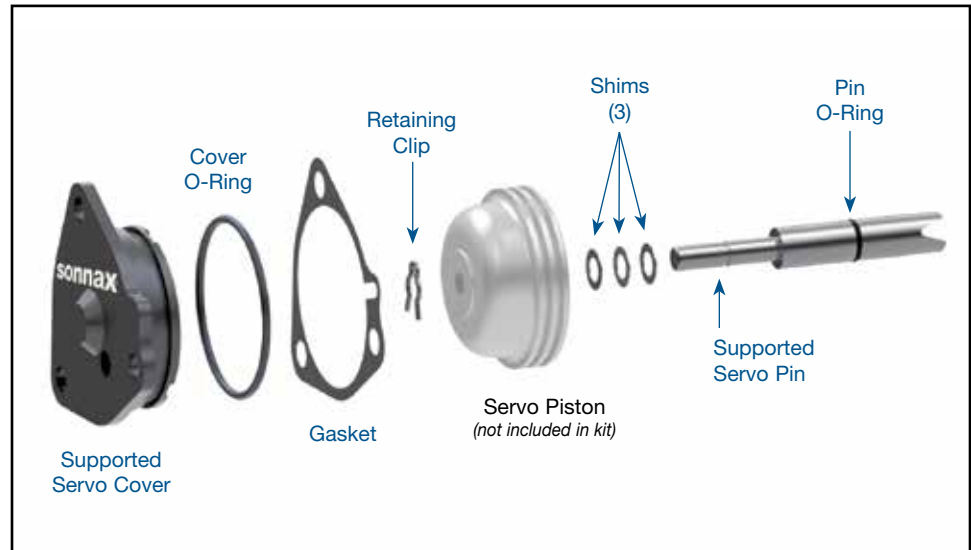

1. Assemble servo piston (not included) onto Sonnax pin (**main photo**).
2. Install Sonnax retaining clip.
3. Check for clearance or play between piston and clip. If clearance exists, remove clip add Sonnax shims between pin and piston to minimize clearance or play between piston and clip (**main photo**).
4. Install Sonnax O-ring on servo pin and lubricate.
5. Using round file or fine sandpaper, remove sharp edge of servo pin bore to prevent O-ring damage during installation (**Figure 1**). Clean thoroughly after removing sharp edge.
6. Install servo piston assembly (with piston seals and return spring) into case.
7. Install servo cover with Sonnax O-ring, gasket, plug and 3 bolts.
8. Adjust servo using typical procedures.



NOTE: Do not install OE cushion spring and washer between pin and piston. Sonnax kit is intended to be used without these OE components.

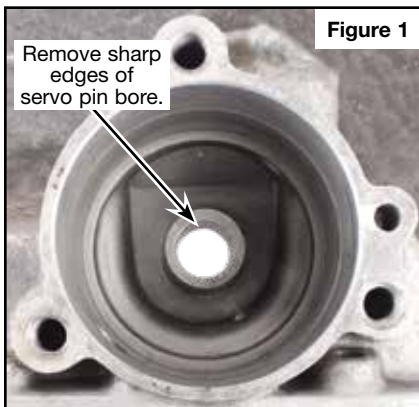

Figure 1

