

Bore Sizing Tool

Part No.

92835-BST

NOTE: This bore sizing tool is to be used to prepare the bore for installation of the Sonnax oversized solenoid switch valve in kit 92835-32K.

Chrysler 40TE, 40TES, 41AE, 41TE, 41TES, 42LE, 42RLE, 45RFE, 545RFE, 62TE, 65RFE, 66RFE, 68RFE

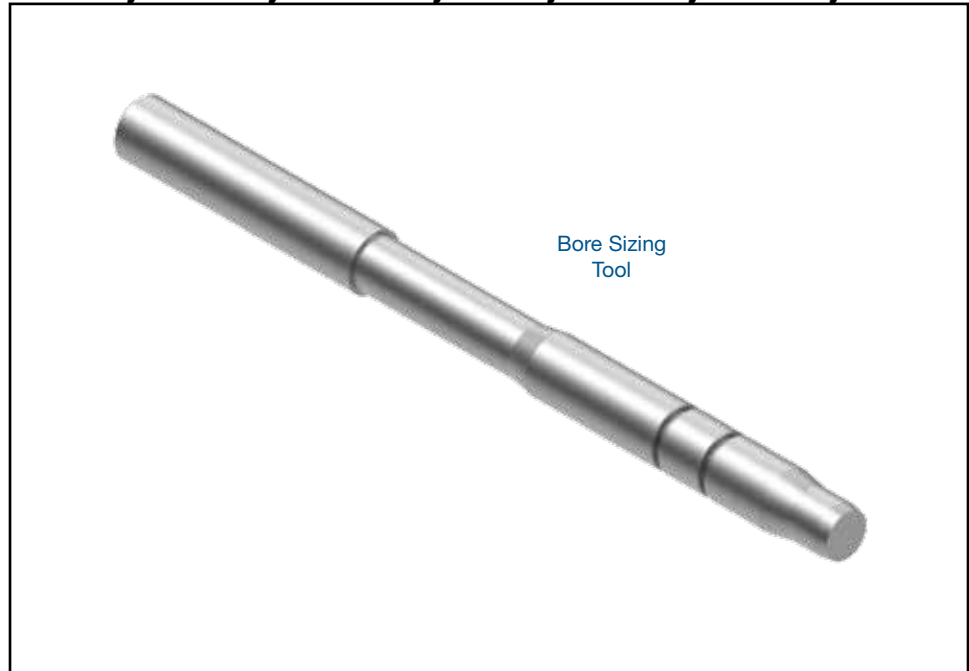

1. After reaming, clean valve body and bore thoroughly before using Sonnax bore sizing tool 92835-BST.



NOTE: The end of bore sizing tool is tapped to allow use of a slide hammer with a 5/16-18 UNC threaded adapter.

2. Insert bore sizing tool into reamed solenoid switch valve bore. Press into bore until tool bottoms out.
3. Remove sizing tool and check to see if plug valve moves freely within bore.
4. If valve does not move freely, reinstall bore sizing tool and tap the sizing tool back and forth in bore using a hammer and screwdriver inserted through the ports and into the tool grooves (**Figure 1**). This will smooth out any ridges in bore. Repeat process until valve strokes freely.

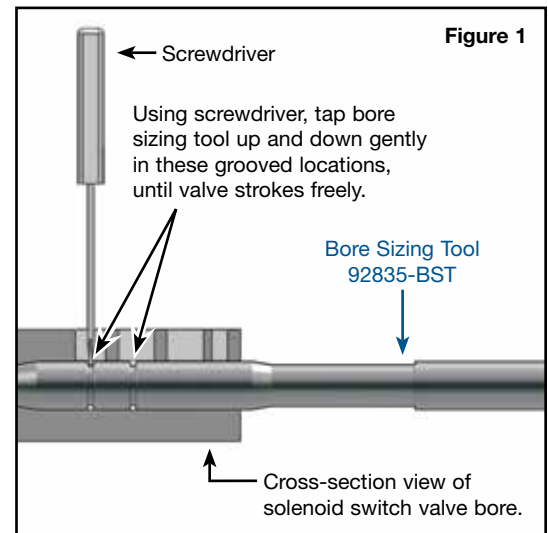

CAUTION: Screwdriver must only contact the bore sizing tool at groove (**Figure 1**). Do not contact machined face of tool.