

Oversized VSTV Valve



Part No.

33741Q-01

Tool Kit



Part No.

F-33741Q-TL

- Reamer
- Reamer Jig
- Guide Pin

NOTE: Sonnax “F-Tool” kits designed to service a specific bore require the VB-FIX, a self-aligning valve body reaming fixture. More information and instructions can be found online at www.sonnax.com.

VW/Audi OAW

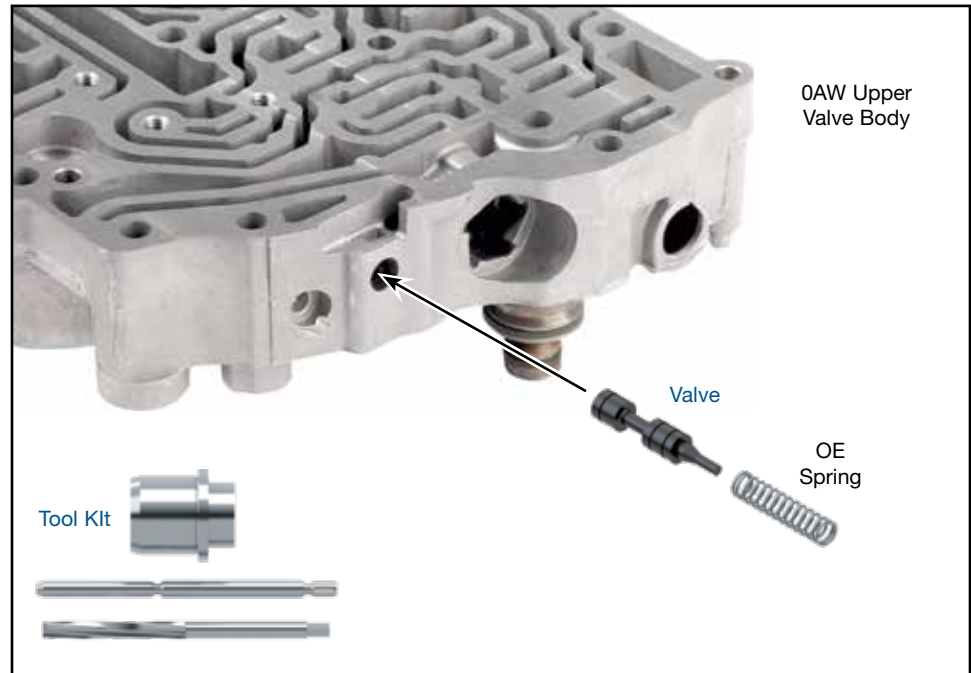

1. Disassembly

- Remove OE retainer and spring and set aside for reuse.
- Remove and discard OE valve.

2. Bore Reaming

Ream VSTV bore (for reaming instructions/reamer care, please visit www.sonnax.com). Sonnax reaming tool kit **F-33741Q-TL** and **VB-FIX** are required for this operation.

3. Installation & Assembly

- Ensure valve bore and valve body are clean and clear of debris.
- Install Sonnax valve with stem facing outward.
- Reinstall OE spring and secure with OE retainer.

4. Final Testing

Vacuum testing at the port(s) indicated holds the recommended minimum 18 in.-Hg.

