

FORD E4OD, 4R100 ZIP KIT®

PART NUMBER E4OD-4R100-ZIP

QUICK GUIDE

Parts are labeled here in order of installation. See other side of sheet for details on kit contents.

INSTALLATION DIAGRAM

Pump Body
4R100 Shown



1

See Note on Installation Steps (Pg 2).



2

3

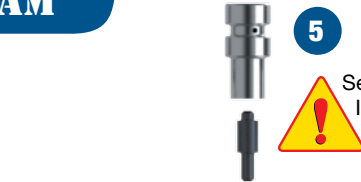

5

See Note on Installation Steps (Pg 2).

Upper Control Body
E4OD Shown



Stator Support
E4OD Shown



Plug line-to-lube hole if present.

See Note on Installation Steps (Pg 2).



4

16 Plastic Checkballs

(16)	(3)
5/16" Dia.	1/4" Dia.

Accumulator Control Body
E4OD Shown



See Note on Installation Steps (Pg 2).

No I.D. Groove

9



3-4 Location

8



2-3 Location

See Note on Installation Steps (Pg 2).

Note I.D. Groove

See Note on Installation Steps (Pg 2).

Note I.D. Groove

7



1-2 Location

6



10 11 12 13 14 15

Reference pages 2-3 in Technical Booklet.

In addition to general rebuilding tips and technical information, the technical booklet included in this kit contains vacuum testing and additional repair options for higher mileage units or for repairing specific complaints which are beyond the scope of this kit.

Kit Contents & Installation Steps

Step 1 Replace OE TCC Control Plunger Valve & Sleeve



CAUTION: Use in PWM units only. If core does NOT have this, do not install this assembly. Go to step 2.

Packaging Pocket 1

- Valve
- Sleeve

Step 2 Replace OE Pressure Regulator Valve



CAUTION: If a line-to-lube orifice has been drilled into pump casting wall, it must be plugged.

FITS: E40D and 4R100 with F1, F5, F8 and E9 stamped pump castings.

Packaging Pocket 2

- Valve

Step 3 Replace OE Boost Assembly

Place O-rings into narrow sleeve grooves. Lubricate with Sonnax Slippery Stick **O-LUBE** and roll on bench to size.

Packaging Pocket 3

- Valve
- Sleeve
- O-Rings (3) 1 Extra

Step 4 Replace OE Front Lube/ Drainback Valve

Use common sheetrock screw to remove orifice cup plug. Discard. Remove and discard existing ball seat, spring and valve. Clean bore. Place new assembly into bore, ball seat first. Lightly stake orifice cup plug into bore, .030-.060" below flush.

Packaging Pocket 4

- Valve Assembly
- Orifice Cup Plug

Step 5 Replace OE Low/Reverse Modulator Plunger Assembly



CAUTION: Used in '96-later E40Ds, all 4R100s.

Packaging Pocket 5

- Valve
- Sleeve

NOTE: The parts listed here may be protected by patent 6,826,908.

Step 6 Replace OE Line Pressure Modulator Plunger Assembly

Place O-ring into narrow groove. Lubricate with Sonnax Slippery Stick **O-LUBE** and roll on bench to size.

Packaging Pocket 6

- Valve
- Sleeve
- O-Rings (2) 1 Extra

Step 7 - 9 Replace OE Accumulator Control Valves



CAUTION: Recommend doing one at a time to keep springs in correct bore.

Remove components from bore. Discard accumulator control valve, keep all other components. Install replacement valve. If valve sticks in bore due to casting wear or ridges, bore sizing with Sonnax bore sizing tool **34948-12** (sold separately) is recommended. If firmer than OE shifts are desired, add shims as needed into appropriate accumulator control valve spring pocket.

- 1 shim = slightly firmer than OE
- 2 shims = sufficient for heavy-duty use

Reinstall OE spring. Place included retainer into OE retainer, and install into casting while compressing spring.

Packaging Pocket 7

- 1-2 Accumulator Valve
- Shims (2)
- Retainer

Packaging Pocket 8

- 2-3 Accumulator Valve
- Shims (2)
- Retainer

Packaging Pocket 9

- 3-4 Accumulator Valve
- Shims (2)
- Retainer

Step 10 - 15 Replace OE Case Components

Reference Technical Booklet pages 2-3 to install remaining Zip Kit components in Case.

- Intermediate Clutch Feed Seal
- Direct Clutch Feed Seal
- EPC Stemmed Relief Valve
- Rear Case Bushing
- Center Support Gasket
- Sure Lock Overdrive Spiral Snap Ring
- Rear Planet Endplay Shims (2)

Step 16 Replace OE Checkballs

Checkball locations vary by application. Reference OE material for proper location.

Packaging Pocket 12

- Checkballs (16) 5/16" dia.
- Checkballs (3) 1/4" dia.

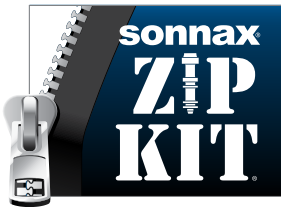

FORD E4OD, 4R100 ZIP KIT®

PART NUMBER E4OD-4R100-ZIP

INSTALLATION & TESTING BOOKLET

Component and Solenoid Application Chart

Figure 1

GEAR	Park/ Neutral	Reverse	OD - 1st	OD - 2nd	OD - 3rd	OD - 4th	OD - 3rd**	M - 2nd	M - 1st	
FWD Clutch			On	On	On	On	On	On	On	
Int. Clutch				On	On	On	On	On		
Direct Clutch		On			On	On	On			
O.D. Clutch						On				
Coast Clutch		On					On	On	On	
Intermediate Band								On		
L/R Clutch		On							On	
O.D. Roller		Hold	Hold	Hold	Hold		Hold	Hold	Hold	
Int. Sprag				Hold				Hold		
Low Roller			Hold						Hold	
Solenoids	SS1	On	On	On	On	Off	Off	Off	On	On
	SS2	Off	Off	Off	On	On	Off	On	On	Off
	CCS	Off	Off	Off*	Off*	Off*	Off	On	On	On
	TCC	Off	Off	On*	On*	On*	On*	On*	On*	Off

*On = If the PCM determines that powertrain operating conditions exist for TCC apply, the TCC solenoid may be On (Modulating with PWM TCC units) in any forward gear except Manual 1st.

*Off = Will be "On", if the TCS switch is pushed.

**OD-3rd = TCS "On" with TCIL illuminated showing "Off".

Solenoid Connector Pin Identification & Function

Figure 4

Pin No	Description
1	Vehicle Power in for Solenoids (VPWR)
2	Shift Solenoid "B" (2) Ground from PCM
3	Shift Solenoid "A" (1) Ground from PCM
4	Converter Clutch Solenoid Ground from PCM
5	Coast Clutch Solenoid Ground from PCM
6	Not Used
7	Transmission Fluid Temp Sensor
8	Transmission Fluid Temp Sensor (Signal Return)
9	Not Used
10	Not Used
11	Electronic Pressure Control (EPC)
12	Vehicle Power in for EPC Solenoid (VPWR)



Figure 2

Zip Kit Application Info

This Zip Kit services E4OD and 4R100 transmissions. While there are many similarities and shared components between the E4OD and 4R100, significant differences pertain to some components in this kit. Verify transmission type and production year prior to installing components.

Solenoids

The E4OD and 4R100 use solenoid blocks that are bolted to the case beside the valve body. These are prone to contamination and wear, and should be resistance tested for electrical failures. OE replacements and Sonnax remanufactured solenoid blocks are available thru your distributor (Figure 2).

- **36424A:** Sonnax Remanufactured Solenoid Block for E4OD 1989-1994.
- **36424B:** Sonnax Remanufactured Solenoid Block for E4OD 1995-1998 and 4R100 non-PWM '98-later.
- **36424D:** Sonnax Remanufactured Solenoid Block for 4R100 PWM TCC, '98-later.

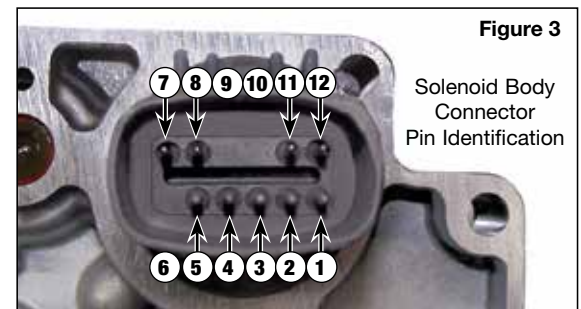

Figure 3

Solenoid Resistance Chart

Figure 5

Solenoid	Solenoid Body Pin Numbers	Resistance
Shift Solenoid "B" (2)	1 & 2	20 - 30 Ohms
Shift Solenoid "A" (1)	1 & 3	20 - 30 Ohms
TCC Solenoid (On-Off)	1 & 4	20 - 30 Ohms
TCC Solenoid (PWM)	1 & 4	10 - 20 Ohms
Coast Clutch Solenoid	1 & 5	20 - 30 Ohms
Electronic Pressure Control Solenoid	11 & 12	3 - 5 Ohms
Transmission Fluid Temp Sensor	7 & 8	Varies with Temperatures

Bolt Color Code		Bolt Case Location
1	Pink	Solenoid Assembly (Nut)
2	Yellow	Lower-to-Upper Control Body Bolts
9	Blue	Solenoid Assembly Bolts
13	Red	Accumulator Control Body
16	Green	Main Control Valve Body

NOTE: Torque all bolts to 80-100 in-lb.

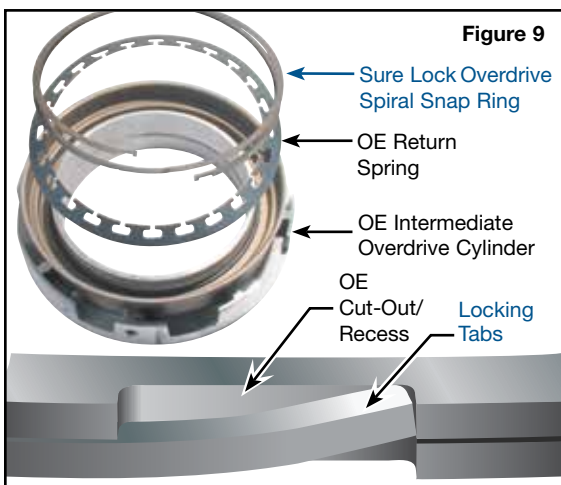
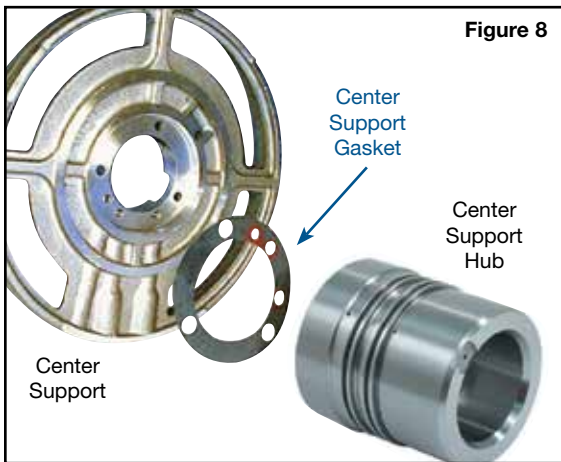
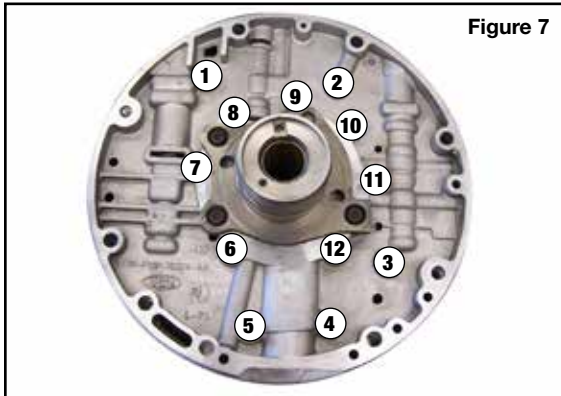

Zip Kit Instructions

1. Valve Body Removal from Case (Figure 6 & Color Chart)

- Remove 13 (red) accumulator control body bolts.
- Remove the main control body assembly by removing 16 (green) bolts.



NOTE: Do not remove the two lower-to-upper control body bolts (yellow).

- Remove 9 bolts (blue), 1 nut (pink), and solenoid assembly.
- Remove the two lower-to-upper control body bolts (yellow).



NOTE: Check ball locations vary significantly between applications and production year. Reference OE manual for proper check ball sizes and locations for specific units.

- Reference Quick Guide to install all valve body components.

2. Pump Disassembly (Figure 7)

- Remove pump from transmission following OE instructions.
- Remove 12 bolts and separate the pump control body from the pump body.
- Reference Quick Guide to install all pump components.

Install Case Components

1. Install Rear Case Bushing (Individually Packaged)



NOTE: Enclosed bushing services all 4R100s, '95-later E40Ds.

- Remove and discard OE bushing.
- Remove any ridge or case material with hone if bore inner diameter is irregular or not center machined.
- Apply Loctite® sealant to case bore.
- Align lube hole of Sonnax bushing with hole in case and three grooves to front of case.
- Press bushing to proper depth. Sonnax installation tool **T36008A** is available separately to aid in installation.
- Confirm lubrication hole is properly lined up and correct clearance has been maintained between bushing and output shaft.

2. Install Center Support Gasket (Individually Packaged)

- Remove burrs and sharp edges on the aluminum center support contact surface.
- Using a medium grit oil stone, smooth the mating hub surface.
- Clean both parts including the tapped holes with solvent.
- Lightly coat gasket surface with TransJel and place it in the center support counter bore with beaded gasket surface against center support.
- Align gasket holes with center support and set hub in place (Figure 8).
- Apply Loctite® 242 thread locker on the three M6 mounting screws, following the Loctite® instructions.
- Install screws and progressively torque to 75-85 in-lb initially, then torque to 100-120 in-lbs.

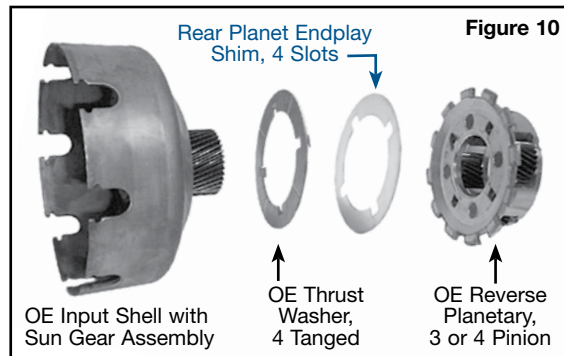

3. Replace OE Overdrive Piston Return Spring Retaining Ring (Individually Packaged)

- Remove and discard OE retaining ring.
- Assemble overdrive piston assembly using Sure Lock retaining ring, ensuring tabs on ring are locked as shown (Figure 9).



NOTE: Be sure snap ring is installed correctly. Failure to install correctly may result in unit failure.

4. Install Endplay Shims (Individually Packaged)

- Install Sonnax shims under the 4-tanged thrust washer, located between the reverse planetary carrier and the input shell (Figure 10).
- When final assembly is completed, total endplay should be inspected with a H gauge, depth mic., or dial caliper. The OE endplay is .075". The recommended endplay is .040" or less.



NOTE: The Sonnax shim does not reduce output shaft free play and will not fit in late-model applications with six pinion carriers.

5. Install Intermediate & Direct Clutch Feed Seal Kit (Packaging Pocket 10)



NOTE: These intermediate and direct clutch feed seals are installed after internal parts are assembled and before valve body is installed.

- Due to casting variations on late 4R100 units, the alignment nub may need to be cut off the direct clutch seal. Measure distance from valve body gasket surface to the cast passage (Figure 13):
 - If less than .625", install Sonnax seal as-is
 - If more than .625", cut nub off seal (Figure 11)
- Coat rubber seal with assembly lube.
- Align locator guide nub with slot in case and insert Sonnax rubber seal into feed port (Figure 12 & 13).
- Install Sonnax aluminum seal adapter tube followed by Sonnax spring.

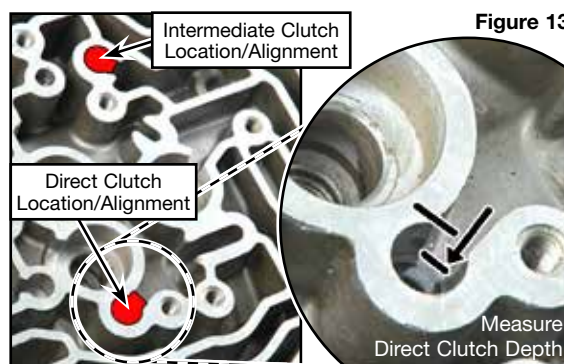
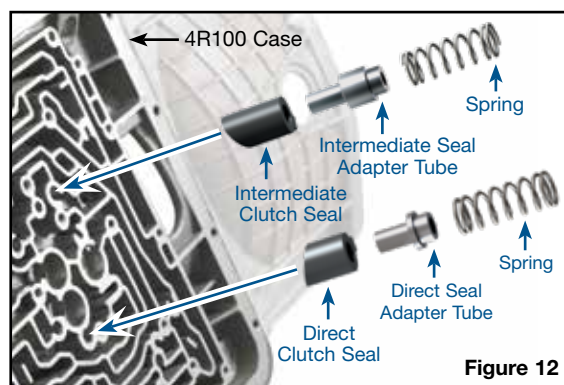
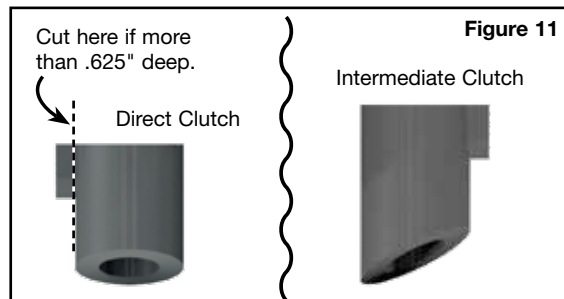

6. Replace OE EPC Ball (Packaging Pocket 11)

- Replace OE EPC relief ball with Sonnax stemmed relief valve. Location in case is same for all units and production years (Figure 14).

Reassembly

- For valve body and solenoid block, reverse steps in disassembly section. Torque all bolts to 80-100 in-lb.
- For pump body, use OE specified pump banding tool for proper pump half alignment. Loosely install 11 bolts. Align pump halves. Tighten all bolts to 20 ft-lb.

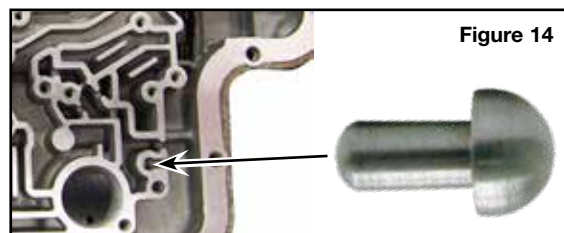

Critical Wear Areas & Vacuum Test Locations



NOTE: OE valves are shown in rest position and should be tested in rest position unless otherwise indicated. Test locations are pointed to with an arrow. Springs are not shown for visual clarity. Low vacuum reading indicates wear and Sonnax parts are noted for replacement.

Lower Control Body • 4R100 Non-PTO Shown

NOTE: Worm tracks and test locations same for '96-'98 E40D.
Worm tracks and test locations different for '89-'95 E40D.
Worm tracks slightly different for PTO 4R100, test locations are the same.



For specific vacuum test information, refer to individual part instructions included in kits and available at www.sonnax.com.

Engagement Control Valve

- Delayed Forward & Reverse engagement
- Burnt Forward clutch
- Burnt Direct clutch

1-2 Manual Transition Valve

- Delayed Reverse
- Reverse slip
- Low/Reverse clutch failure
- Low line pressure in Reverse & manual low

Replace with **Sonnax Part No. 36947-13K**
Requires F-36947-TL13 & VB-FIX

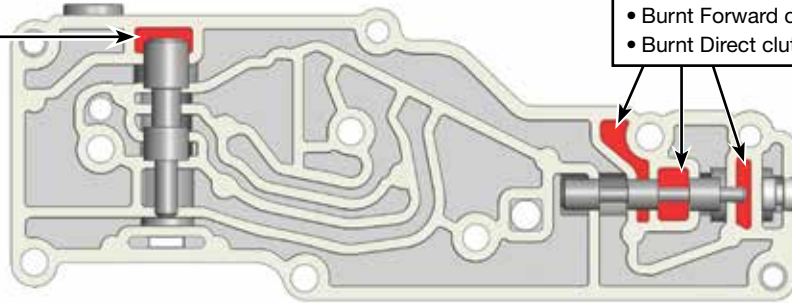

Upper Control Body • 4R100 Non-PTO Shown

NOTE: Worm tracks and test locations same for '96-'98 E40D.
Worm tracks and test locations different for '89-'95 E40D.
Worm tracks slightly different for PTO 4R100, test locations are the same.

Low/Reverse Modulator Valve Plunger & Sleeve

- No engine braking
- Burnt Low/Reverse clutch
- Low pressure at Low/Reverse clutch

Replace with **Sonnax Part No. 36947-06K***

Note: Check for wear at inside diameter of sleeve.

Note: Seal port on opposite side.

Low/Reverse Modulator & Low/Reverse Modulator Valves

- No engine braking
- Burnt Low/Reverse clutch
- Low pressure at Low/Reverse clutch

2-3 Shift Valve

- 2-3 Shift concerns
- Burnt Direct clutch

3-4 Shift Valve & 4-3-2 Timing Valve

- 3-4 Shift concerns
- Burnt Direct clutch
- Manual low concerns

Drive 2 Valve

- Reverse concerns

1-2 Shift Valve

- No 2nd
- 1-2 Shift concerns

Test: Flip casting over and test at this orifice. Seal this side of casting with foam mat.

4-3-2 Timing Valve & Control Valve Shift Timing Plunger

- Manual low concerns

Coast Clutch Shift Valve

- Burnt coast clutch

Solenoid Regulator Valve

- 2nd or 3rd Gear starts
- TCC cycling or slip
- Reduced lube oil from the center support

Replace with **Sonnax Part No. 36947-14**
Requires F-36947-TL14 & VB-FIX

Part numbers with an asterisk () are included in this Zip Kit.

Accumulator Control Body • 4R100 Non-PTO Shown

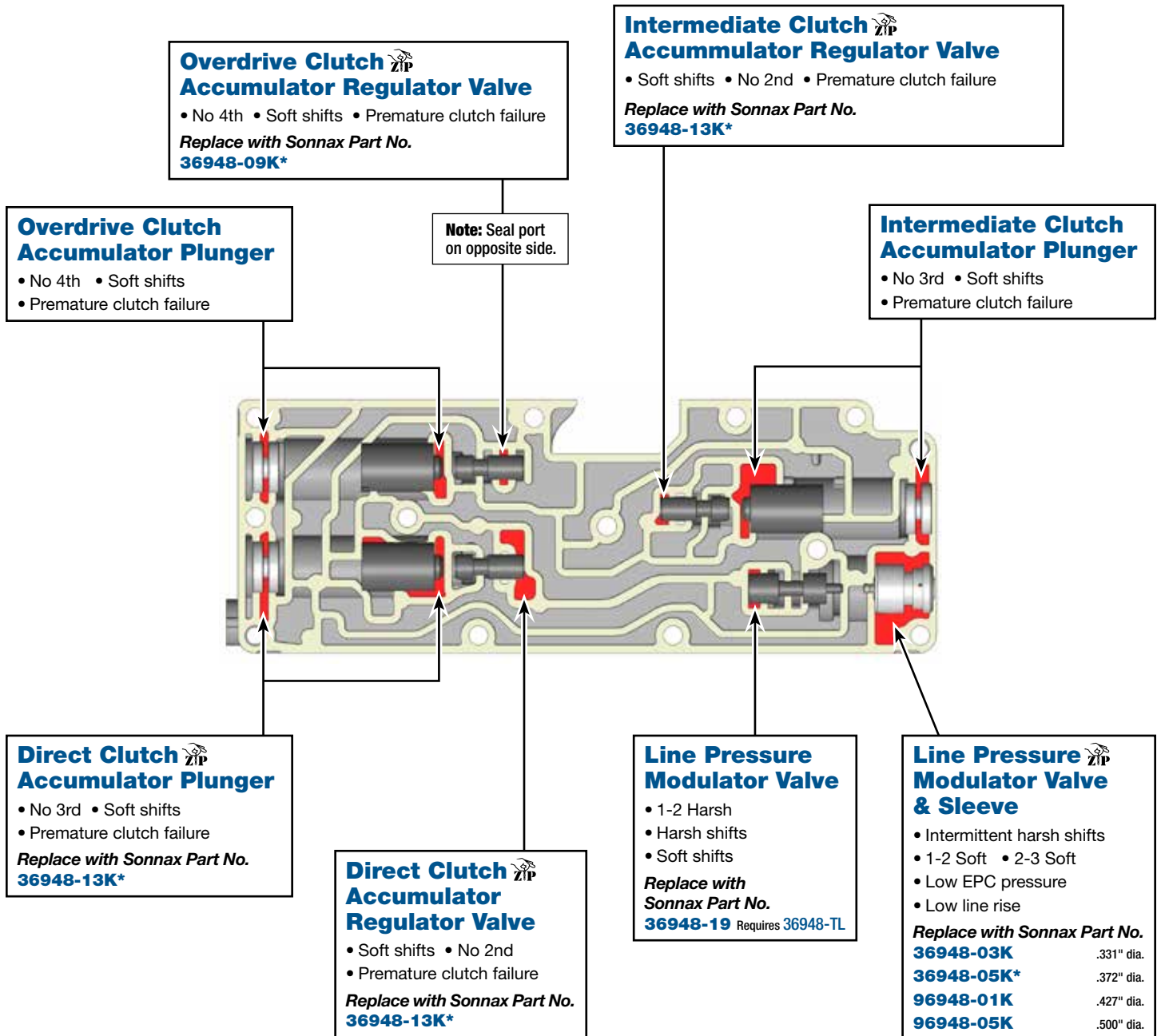

Part numbers with an asterisk () are included in this Zip Kit.

Critical Wear Areas & Vacuum Test Locations



NOTE: OE valves are shown in rest position and should be tested in rest position unless otherwise indicated. Test locations are pointed to with an arrow. Springs are not shown for visual clarity. Low vacuum reading indicates wear and Sonnax parts are noted for replacement.



For specific vacuum test information, refer to individual part instructions included in kits and available at www.sonnax.com.

Pump Body • E4OD Shown

NOTE: Test ports on 4R100 slightly different.

Main Regulator Valve (Inboard)

- Code 62, 628, 1744
- Engine stall on engagement in Reverse
- Engine stumble on engagement in Reverse
- High line pressure
- Overheated converter

Replace with Sonnax Part Nos.

36424-04K or **36424-16K** Requires F-36424-TL16C & VB-FIX

Main Regulator Valve & Sleeve (Outboard)

- Soft shifts
- Delayed Reverse
- Low line rise

Replace with Sonnax Part Nos.

36424-03K Factory Style, No O-Rings or **36424-01K** O-Ring Style

Converter Regulator Valve

- Internal converter damage
- Excess converter pressure
- Low converter & converter clutch apply pressure

Replace with Sonnax Part No.

36424-11K Requires F-36424-TL11C & VB-FIX

Converter Clutch Control Valve

- Lockup shudder
- TCC cycling

Replace with Sonnax Part Nos.

36424-08K 4R100 PWM Only or **36424-15K** 4R100 PWM Only, Requires F-36424-TL15C & VB-FIX

NOTE: 4R100 Port is different. Must seal indicated air bleed when testing these ports.

Note: Seal holes on opposite side.

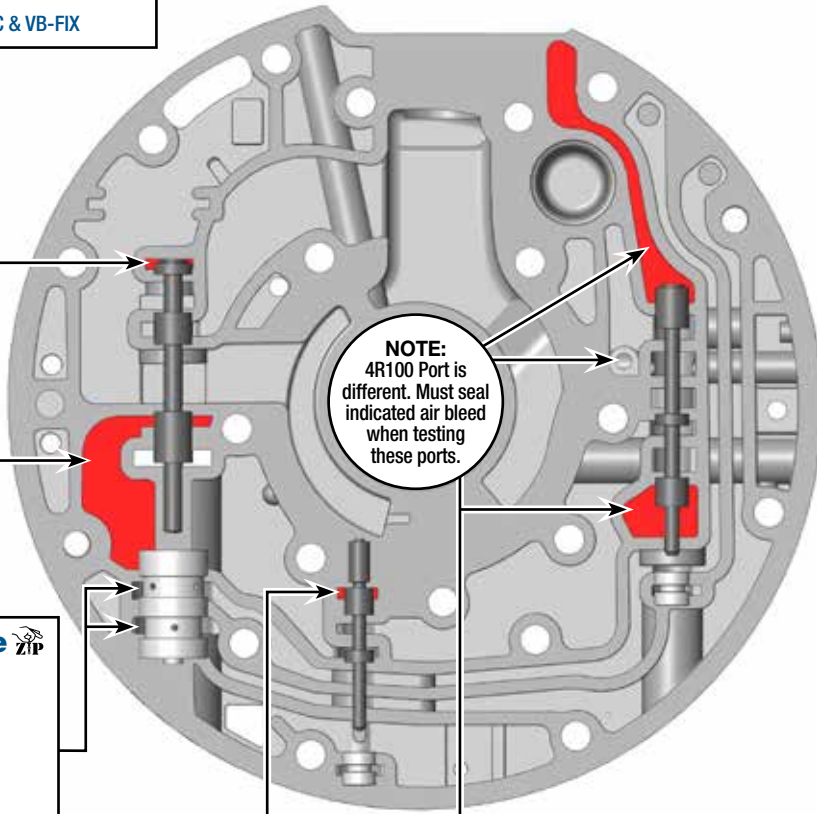

OE Exploded View

Lower Control Body

4R100 Non - PTO Shown

NOTE: E4OD is the same.

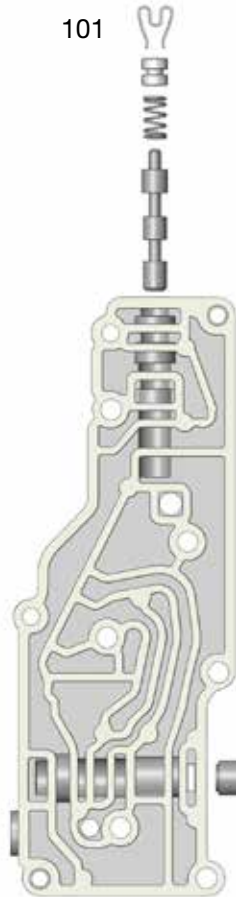

< Lower Control Valve Body Descriptions

I.D. No.	Description
101	Engagement Control Valve
102	1-2 Manual Transition Valve

Upper Control Body

4R100 Non - PTO Shown

NOTE: E4OD Worm tracks and valves vary slightly.

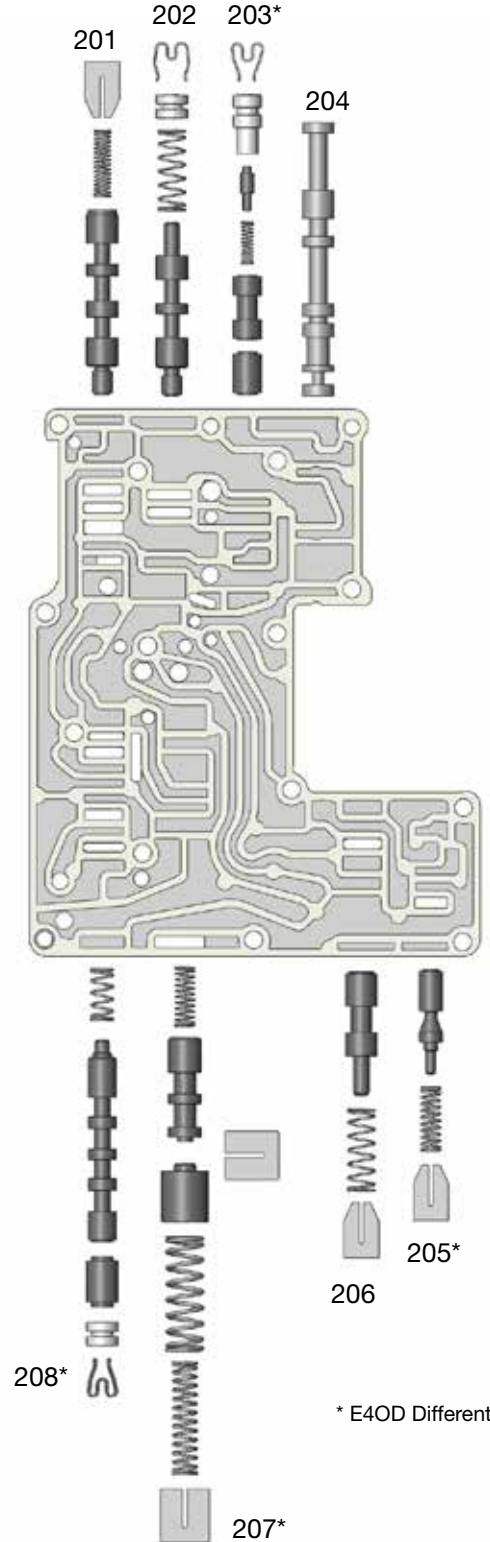

Upper Control Valve Body Descriptions >

I.D. No.	Description
201	2-3 Shift Valve
202	3-4 Shift Valve
203*	Low/Reverse Modulator Valve (Inboard)
	Low/Reverse Modulator Valve (Center)
	Low/Reverse Modulator Valve Plunger & Sleeve (Outboard)
204	Manual Control Valve
205*	Solenoid Regulator Valve
206	Coast Clutch Shift Valve
207*	4-3-2 Timing Valve (Inboard)
	Control Valve Shift Timing Plunger (Outboard)
208*	Drive 2 Valve (Inboard)
	1-2 Shift Valve (Outboard)

* E4OD Different

OE Exploded View

Accumulator Control Body 4R100 Non - PTO Shown

Pump Body E4OD Pump Body Shown

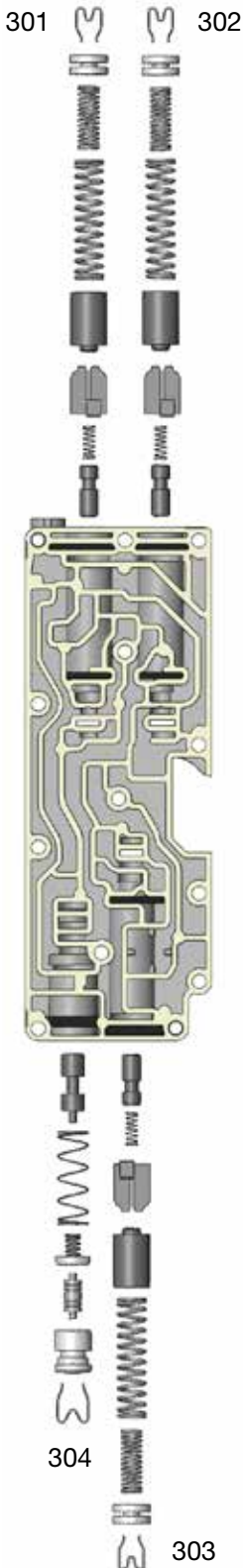

< Accumulator Control Body Descriptions

I.D. No.	Description
301	Direct Clutch Accumulator Regulator Valve (Inboard)
	Direct Clutch Accumulator Plunger (Outboard)
302	Overdrive Clutch Accumulator Regulator Valve (Inboard)
	Overdrive Clutch Accumulator Plunger (Outboard)
303	Intermediate Clutch Accumulator Regulator Valve (Inboard)
	Intermediate Clutch Accumulator Plunger (Outboard)
304	Line Pressure Modulator Valve (Inboard)
	Line Pressure Modulator Plunger Valve & Sleeve (Outboard)

Pump Body Descriptions >

I.D. No.	Description
401	Main Regulator Valve (Inboard)
	Main Regulator Valve & Sleeve (Outboard)
402	Converter Regulator Valve
403A	E4OD Converter Clutch Control Valve
403B	4R100 Non-PWM Converter Clutch Control Valve
403C	4R100 PWM Converter Clutch Control Valve (Inboard)
	Converter Clutch Control Plunger Valve & Sleeve (Outboard)

