

### Alignment Hole Key

- Red ● = Alignment Pins
- Black ● = Push Pin Locations
- Blue ● = Optional Bolt Locations

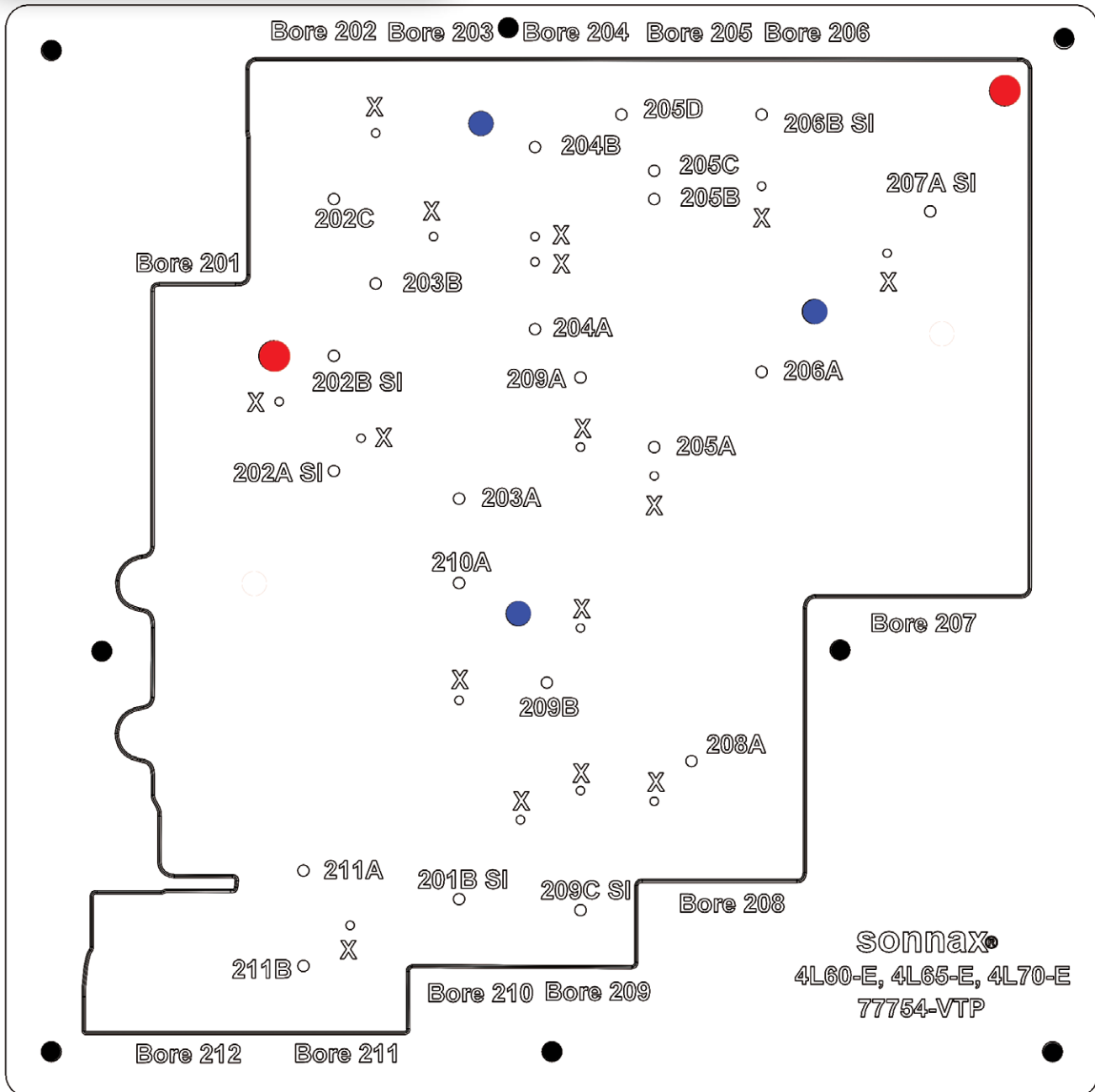

## Vacuum Test Plate Kit

### Part No.

# 77754-VTP



- Plate
- Seal
- Push Pins (10)
- Alignment Pins (2)
- Bolts (3)
- Washers (3)
- Wing Nuts (3)

2 Extra

## Vacuum Test Stand Kit

### Part No.

# VACTEST-01K

- Vacuum Test Stand
- Test Plate
- Vacuum Plate Sealing Pad
- Vacuum Test Foam Pad
- Push-to-Connect Fitting
- Assorted Testing Tips (6)
- Testing Tip Adapter Tube
- Flexible Tubing
- Flared Tubing with Flared Nut

## Instructions

### 1. Assembly

- Ensure vacuum test plate and seal are both clean and free of debris.
- Install two alignment pins into plate at indicated threaded holes. Thread into non-engraved side of plate (**Figure 1**).
- Place seal onto non-engraved side of plate, aligning orifice holes. Remove any entrapped air between plate and seal by peeling seal up at plate edge. Gradually place seal back on plate from center toward edge.
- Push plastic push pins into seal and plate from seal side, just far enough for head to lightly contact seal.

**NOTE:** Sonnax recommends starting with only four corner locations. If seal sags away from plate, other push pin locations should also be used.

### 2. Testing

- Place assembled vacuum test plate over casting, using engraved casting outline as guide. Alignment pins should enter casting bolt holes.
- Using **VACTEST-01K** (sold separately, **Figure 2**) and small vacuum tip, vacuum test at numbered orifices on plate. These numbers correspond to the bore numbers called out in the exploded view of the valve body on page 6. The chart on page 8 provides descriptions of individual circuit checked and space to document actual vacuum readings and minimum vacuum standards.

**NOTE:** Vacuum test data sheet on page 7 can be used to establish minimum vacuum standards at individual bore locations.

- Light finger-tip pressure may need to be applied on plate during testing. Included bolts, washers and wing nuts can be used at indicated bolt locations for firmer seal, but are not required. If used, place bolts through casting, seal and plate from the back of casting. Tighten wing-nut against plate, finger-tight only.

### 3. Cleaning

Seal and plate can be cleaned as needed with mild soap and water to remove debris.

### 4. What should my vacuum test results be?

While a properly calibrated and maintained test stand will give consistent vacuum reading results for a specific circuit and amount of wear, evaluating these results requires establishing your own pass/fail criteria. Variables which influence vacuum readings are the number of spools tested in a captive circuit, spool diameter size and contact length of the spool within the bore.

Pass/Fail standards are specific to your setup and process, but they also must be based on your experience, quality sensitivity, warranty concerns and cost/pricing structure. Sonnax recommends that you keep a record of vacuum results for each valve body at each tested circuit/port location. This lets you compare results over time to help determine for your shop what an acceptable vacuum reading is for each circuit/port location.

A chart specific to this application is provided in this booklet indicating valve and circuit checked at each orifice location. Room is provided to record results and compare to your minimum vacuum standard. A generic vacuum test data sheet also is provided that can be used to evaluate multiple cores to establish your minimum vacuum standard. If you need fresh documents, you can print or download these pages from this instruction booklet by visiting this vacuum test plate kit product page at [www.sonnax.com](http://www.sonnax.com).

Figure 1

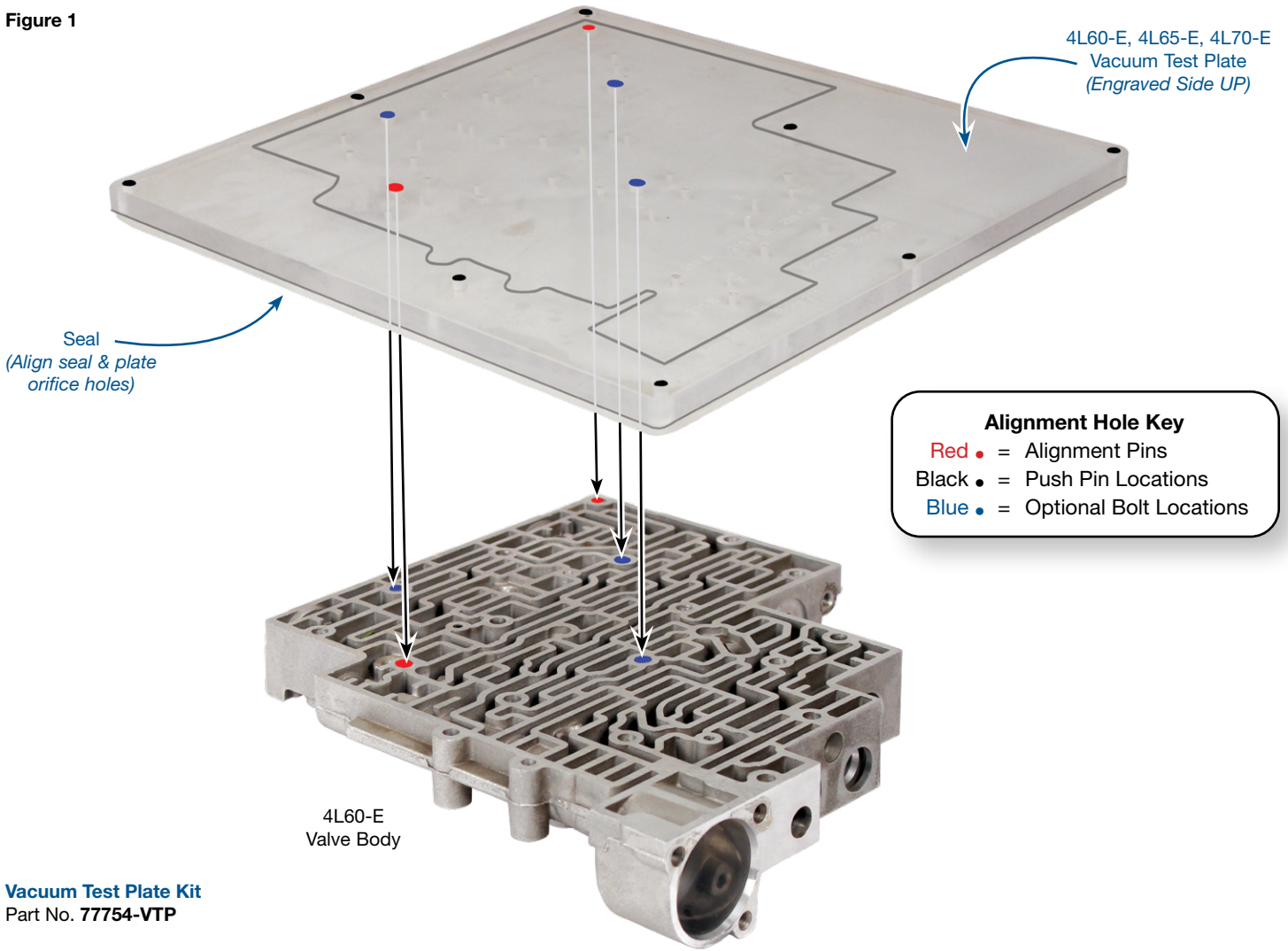

**Vacuum Test Plate Kit**  
Part No. 77754-VTP

Figure 2

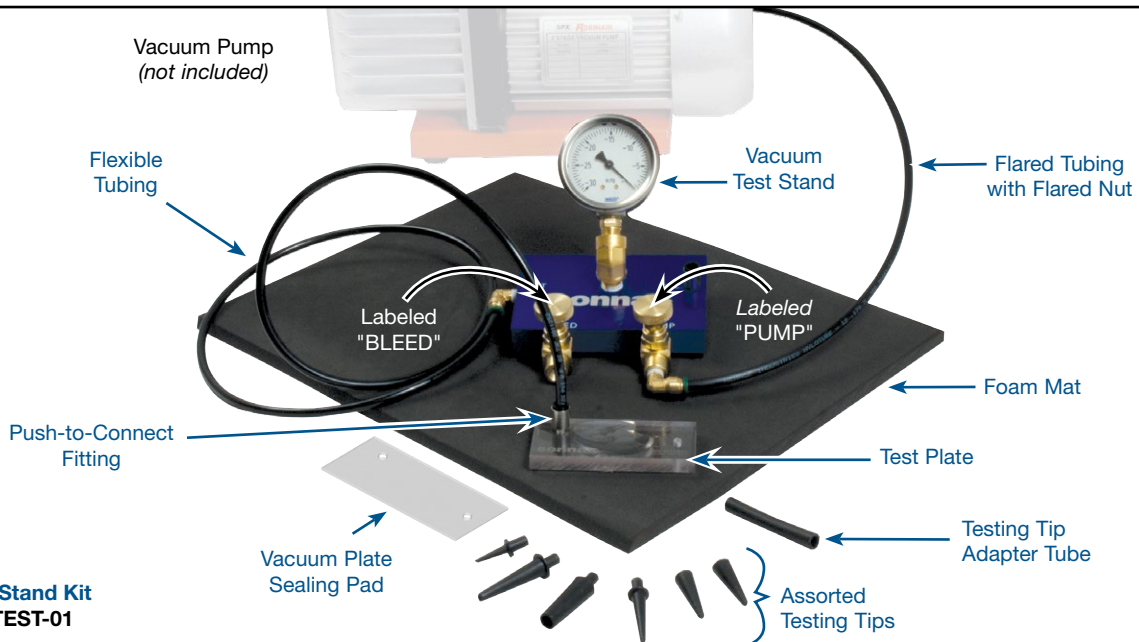

**Vacuum Test Stand Kit**  
Part No. VACTEST-01

**Critical Wear Areas & Vacuum Test Locations**



**NOTE:** OE valves are shown in rest position and should be tested in rest position unless otherwise indicated. Test locations are pointed to with an arrow. Springs are not shown for visual clarity. Low vacuum reading indicates wear and Sonnax parts are noted for replacement.

**Valve Body • 4L60-E Shown**



For specific vacuum test information, refer to individual part instructions included in kits and available at [www.sonnax.com](http://www.sonnax.com).

**3-4 Shift Valve**

- 2nd Gear starts
- 3rd Clutch failure
- 3-4 Shift complaints
- Loss of AFL pressure

Replace with Sonnax Part No. **77754-42K**

Requires F-77754-TL42 & VB-FIX

**4-3 Sequence Valve & 3-4 Relay Valve**

- No 4th gear • 2-4 Band burned
- Low 4th gear pressure

Replace with Sonnax Part Nos. **77964-04K** Requires 77964-RM2 or **77964-14K** Requires F-77964-TL14 & VB-FIX

**End Plugs**

- No 4th gear • Converter issues
- Loss of manual 3rd
- Burnt overrun clutch

Replace with Sonnax Part No. **77964-08K**

**NOTE:** Check for visual wear on plugs.

**TCC Regulator Valve\***

- 1870 Slip code • Harsh 1-2 shifts
- Low TCC apply pressure
- Overheated converter
- Burnt 3-4 clutch

Replace with Sonnax Part Nos. **77754-03K** Non EC3 '97-Earlier or **77754-04K** EC3 '98-Later or **77754-ISO**

Requires varying combinations of tools.\*\*

**Reverse Abuse Bore Plug**

- Delayed Reverse
- Burnt 3-4 clutch
- 3-2 Downshift tie-up

Replace with Sonnax Part Nos. **77754-21** or **77754-58K**

**77754-58K** Requires F-77754-TL58 & VB-FIX

**3-2 Control Valve\***

- 3-2 Concerns

**Reverse Abuse Valve**

- Delayed Reverse
- Burnt Reverse input clutch

Replace with Sonnax Part Nos. **77754-35K** or **77754-58K**

**77754-58K** Requires F-77754-TL58 & VB-FIX

**Forward Abuse Valve**

- Delayed Forward
- Low line pressure upon engagement

Replace with Sonnax Part Nos. **77754-35K** or **77754-58K**

**77754-58K** Requires F-77754-TL58 & VB-FIX

**NOTE:** Check for visual bore wear.

**Forward Abuse Bore Plug**

- Delayed Forward
- Burnt Forward clutch

Replace with Sonnax Part Nos. **77754-21** or **77754-58K**

**77754-58K** Requires F-77754-TL58 & VB-FIX

**1-2 Shift Valve**

- Wrong gear starts
- Gear ratio codes

**2-3 Shift & 2-3 Shuttle Valves**

- Wrong gear starts
- Gear ratio codes

**Low Overrun Valve**

- No engine braking in manual low
- Burnt Low/Reverse clutch

**Actuator Feed Limit Valve**

- Wrong gear starts • No 4th gear
- Solenoid codes • Harsh shifts
- Clutch/Band failure • 2nd Gear starts

Replace with Sonnax Part No. **77754-09K**

Requires 77754-TL

**Accumulator Valve & Sleeve**

- 1-2 Bang shift
- Shortened 2-4 band life

Replace with Sonnax Part Nos. **77777L-K** .330" Dia. or **77777M-K** .341" Dia.

**NOTE:** Check for visual wear in sleeve.

\*\*Tool Combinations Required for TCC Regulator Valve: F-77754-TL4, F-77754-SERV, 77754-R2, 77754-SERV, & VB-FIX depending on particular valve body; SEE INSTRUCTIONS TO DETERMINE

**WARNING:** Tool kit F-77754-SERV is no longer in production. Check with your distributor for availability.

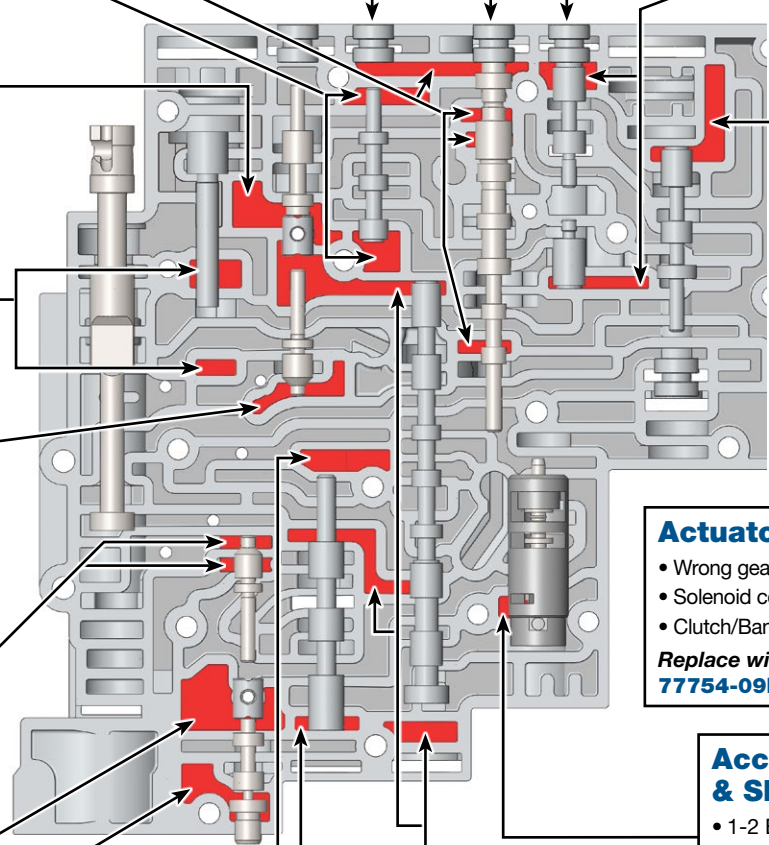

\*NOTE: Valve designs vary by year, however all port locations for vacuum testing are the same.



For specific vacuum test information, refer to individual part instructions included in kits and available at [www.sonnax.com](http://www.sonnax.com).

**Pump Cover (Front)  
4L60-E PWM Shown**

**NOTE:** Worm tracks will vary slightly on non-PWM pump covers, but locations for vacuum testing are identical.

Test this location with valve stroked outboard, as shown.

Must seal orifice on back when testing here.

Test this port with valve blocked inboard.

Seal bore opening with thumb.

**TCC Apply Valve**

- No lockup • Code 1870
- Falls out of lockup hot
- Lockup immediately after 2nd gear

Replace with Sonnax Part Nos.  
**77805-K Non-PWM or**  
**77805E-K PWM**

**Pump Cover (Back)  
4L60-E PWM Shown**

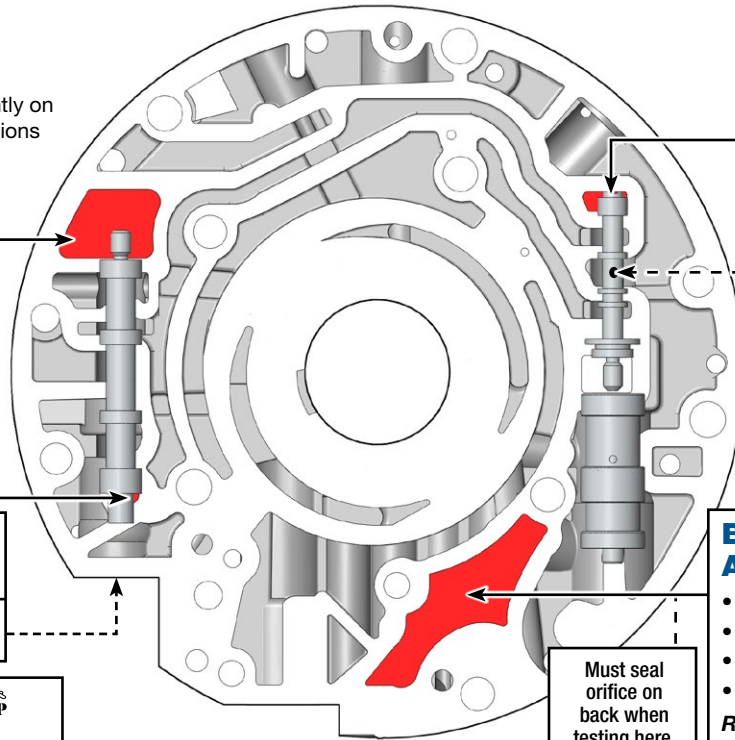

**Pressure Regulator Valve**

- 3-4 Clutch failure
- Excessive pump noise
- Low line pressure during boost
- Reverse chatter

Replace with Sonnax Part No. **77917-07**

Requires **77917-TL** or **77917-TLC**

Seal valve orifice with pencil eraser.

**Boost Valve Assembly**

- 3-4 Clutch failure
- 2-4 Band failure
- Low line rise
- Poor shift quality

Replace with Sonnax Part Nos.

Early Pump Design w/ 1.907" Long Sleeve:

- 77898E-K** Increased Ratio, O-Rings or
- 77898E-4K** Large OE Ratio, O-Rings or
- 77898E-3K** Increased Ratio, Factory Style or
- 77898E-6K** Large OE Ratio, Factory Style or

Late Pump Design w/ 1.890" Long Sleeve:

- 77898E-14K** Standard OE Ratio, O-Rings or
- 77898E-16K** Large OE Ratio, O-Rings

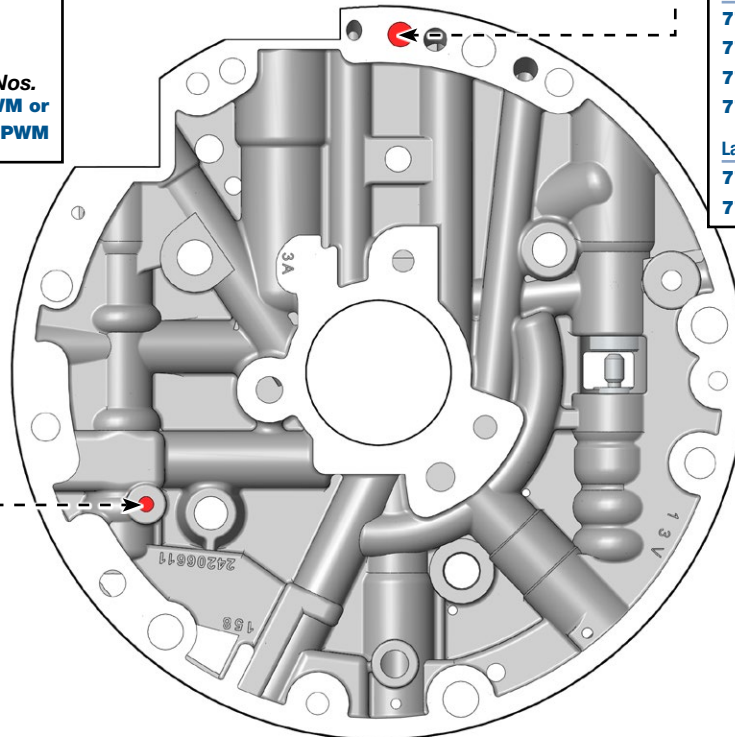

# OE Exploded View

## Valve Body • 4L60-E Shown

**NOTE:** Solenoids not shown.

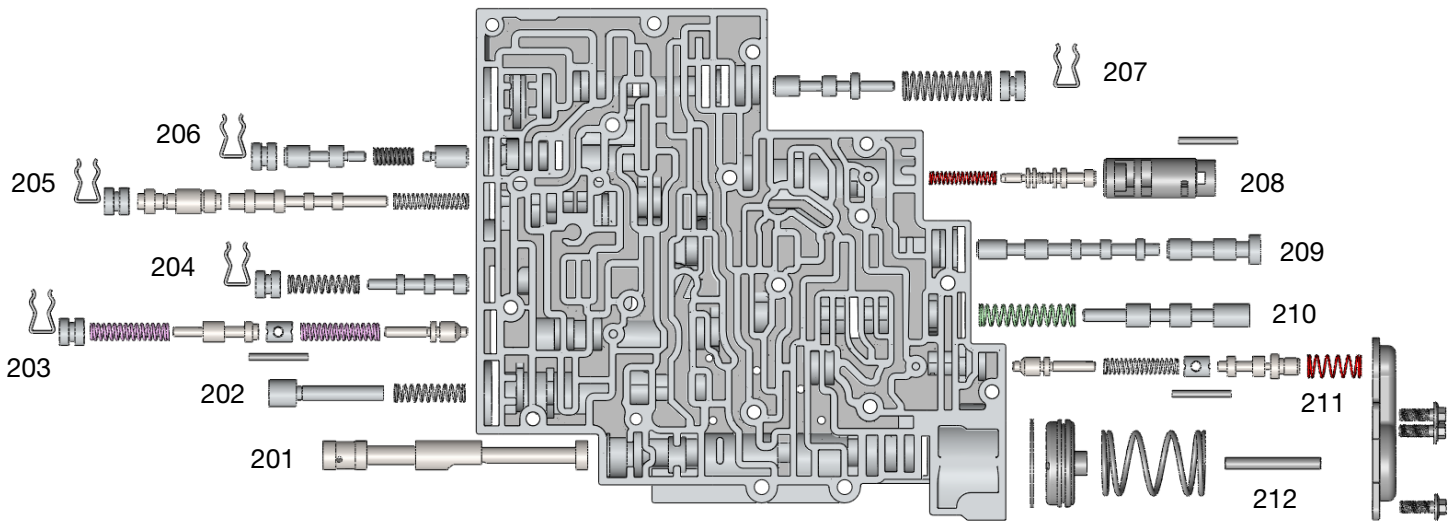

PWM Pump Cover Descriptions	
I.D. No.	Description
101	Pressure Regulator Valve & Boost Valve Assembly
102	TCC Apply Valve
103	Pressure Relief Ball & Spring

Valve Body Descriptions	
I.D. No.	Description
201	Manual Valve
202	3-2 Control Valve
203	Reverse Abuse Valve (Inboard), 3-2 Downshift Valve (Outboard)
204	3-4 Shift Valve
205	4-3 Sequence Valve (Inboard), 3-4 Relay Valve (Outboard)
206	TCC Regulator Valve
207	Actuator Feed Limit Valve
208	Accumulator Valve & Sleeve
209	2-3 Shift Valve (Inboard), 2-3 Shuttle Valve (Outboard)
210	1-2 Shift Valve
211	Forward Abuse Valve (Inboard), Low Overrun Valve (Outboard)
212	Forward Accumulator Piston

## Pump Cover 4L60-E PWM Shown

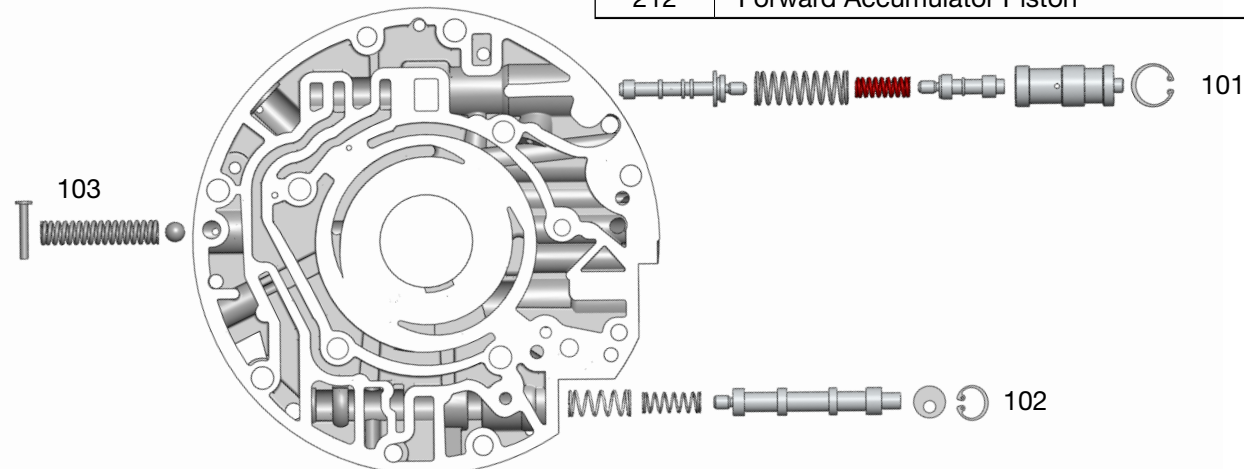

**Application:**

**Vacuum Test Data Sheet**

Bore Locations	Vacuum Readings, in-Hg										Calculated Average Vacuum	Minimum Vacuum Standard	
	Core 1	Core 2	Core 3	Core 4	Core 5	Core 6	Core 7	Core 8	Core 9	Core 10			



The Sonnax vacuum test data sheet is a document that can be printed or downloaded and stored on your computer. This test data sheet helps to track vacuum readings in critical wear areas from up to 10 cores of the same type. Comparing results from 10 cores aids in wear pattern identification.

Recording results allows an average vacuum reading for each bore to be calculated. Your minimum vacuum standard for each bore can be established from this data. These standards should reflect your warranty requirements and customer needs.

# Orifice Legend

 Unit Stock or Tag No. 

Orifice Location	Valve / Circuit Checked	Sonnax Part Number	Actual Vacuum Reading	Minimum Vacuum Standard
202A SI*	3-2 Control Valve, Balance Spool / 3-4 Clutch SI*: For PWM 3-2 Control Valve, '94-earlier	n/a		
202B SI*	3-2 Control Valve, 1st & 2nd Spools / 3-2 Signal SI*: For PWM 3-2 Control Valve, '94-earlier	n/a		
202C	3-2 Control Valve, Outboard Spool / 3-2 Signal	n/a		
203A	Reverse Abuse Valve, Inboard Spool / Reverse (Line)	77754-35K		
203B	Reverse Abuse Bore Plug / 3-4 Clutch	77754-21		
204A	3-4 Shift Valve, Inboard Spool / Signal A	77754-42K		
204B	3-4 Shift Valve, Outboard Spool / D3 (Line)	77754-42K 77964-08K		
205A	4-3 Sequence Valve, Inboard Spool / Servo Feed (Line)	77964-04K		
205B	3-4 Relay Valve, Inboard Spool / Servo Feed (Line)	77964-04K 77964-14K		
205C	3-4 Relay Valve / 2nd (Line)	77964-04K 77964-14K		
205D	3-4 Relay Valve, Outboard Spool / 4th Signal	77964-04K 77964-08K		
206A	TCC Regulator Valve, Isolator Valve / 2nd Clutch, CC Signal	77754-03K, 77754-04K, 77754-ISO		
206B SI*	TCC Regulator Valve, Balance Spool / Regulated Apply SI*: Visually check for bore plug wear, which can also cause TCC related complaints.	77754-03K, 77754-04K, 77754-ISO 77964-08K		
207A SI*	Actuator Feed Limit Valve, Balance Spool / AFL SI*: Test with valve propped open .125" on balance end.	77754-09K		
208A	Accumulator Valve / Accumulator	77777L-K, 77777M-K		
209A	2-3 Shift Valve, Inboard Spool / AFL	n/a		
209B	2-3 Shift Valve, 2-3 Shuttle Valve / D2 (Line)	n/a		
209C SI*	2-3 Shuttle Valve, Outboard Spool / AFL, Signal B SI*: Solenoid must be installed	n/a		
210A	1-2 Shift Valve, Inboard Spool / AFL	n/a		
210B SI*	1-2 Shift Valve, Outboard Spool / D2, 2nd (Line) SI*: Solenoid must be installed	n/a		
211A	Forward Abuse Bore Plug / PR (Line)	77754-21		
211B	Lo Overrun Valve / Lo/Reverse (Line)	n/a		

**NOTE:** "X" orifice locations on plate are for air inlet and do not require testing.

\*SI = Special Instructions