

300mm Performance Converter Kit

Part No.

GM-RK-405WC

- Pilot
- 30-Tooth Turbine Hub
- Sprag Cartridge
- Impeller Hub

Patent No. 6,902,046



NOTE: Street/Strip applications only. This kit must be completed with Sonnax included multi-plate base kit and additional OE salvaged parts.

Included:

Multi-Plate Base Kit

Part No.

GM-RK-20MWC

- Front Cover
- Washer Vespel[®]
- O-Ring Fluorocarbon
- Seal PTFE
- Clutch Plate with Internal Splines, Woven Carbon Frictions
- Clutch Plate with External Splines, Woven Carbon Friction
- Damperless Piston
- Thrust Bearing Turbine-side
- Thrust Bearing Impeller-side



NOTE: The impeller and turbine MUST be furnace-brazed.

GM 4L60-E, 4L65-E, 4L75-E (300mm), Multi-Plate

Unit Size: 300mm • Core: GM 265mm • Dampened: No • Turbine Hub Input Spline Count: 30

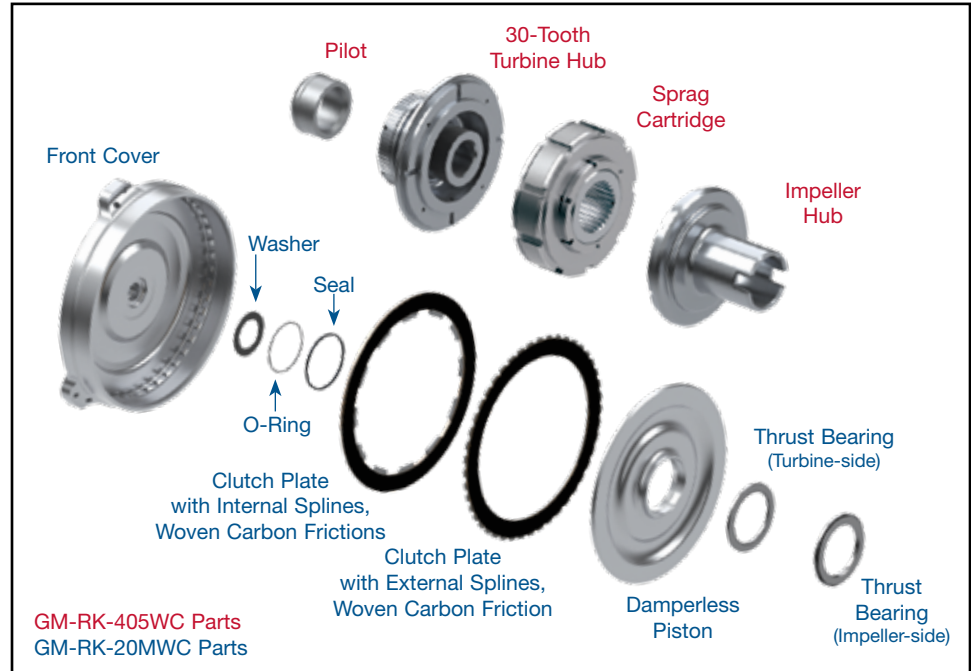

1. Front Cover Assembly

- The front cover must be machined to fit the GM 265mm converter core parts (**Figure 1**).
- The pilot is a sliding-fit to light press-fit on the cover. Insert Sonnax pilot all the way to the back surface of the cover and weld in place at the pilot inside diameter.



CAUTION: Weld the pilot on the cover before assembling the rest of the converter to prevent heat damage to the Vespel[®] washer.

2. Damperless Piston Assembly

- Install Sonnax internal spline clutch plate, followed by Sonnax external spline clutch plate. External spline plate will engage in the cover splines.
- Place Sonnax piston over clutch plates. Rotate piston until it drops and engages with internal spline clutch plate.
- Place Sonnax Vespel[®] washer on Sonnax turbine hub, using assembly gel to hold washer in place.
- Insert turbine hub into piston and check clutch release clearance with a feeler gage. It should measure between .040-.055" (**Figure 2**).

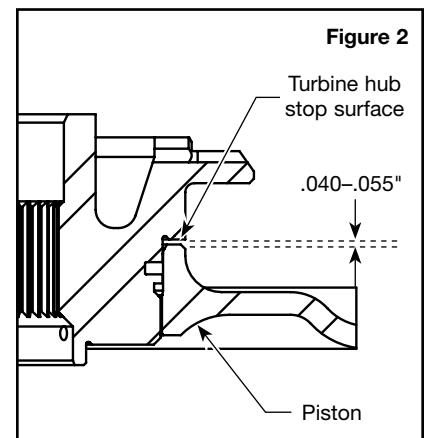
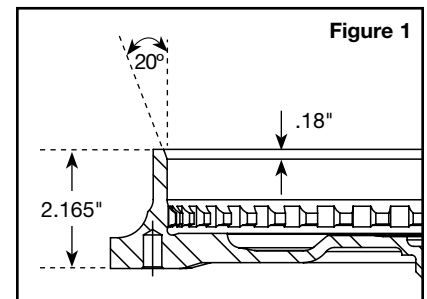

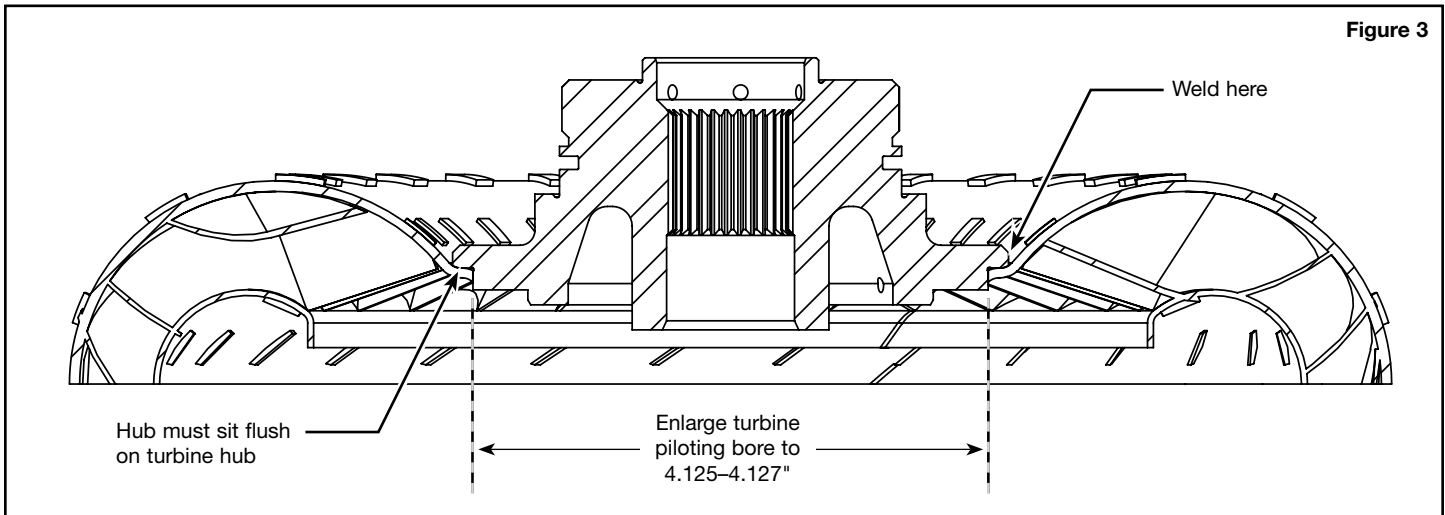

Figure 3

2. Damperless Piston Assembly (continued)

- e. If additional clutch release clearance is needed, the turbine hub stop surface can be machined.
- f. Remove turbine hub from the cover assembly.

3. Turbine Assembly

The Sonnax turbine hubs are designed for GM 265mm cores and allows the use of the sprag cartridge, impeller hub and thrust bearings provided.

- a. Remove OE turbine hub.
- b. Turn the inside of the turbine to 4.125–4.127" (Figure 3).
- c. Weld the turbine hub to the turbine as shown.

4. Piston & Clutch Plate Assembly

- a. Install clutch plates and piston (see step 2 "Damperless Piston Assembly").
- b. Install Sonnax O-ring, then the Sonnax PTFE seal onto turbine hub.
- c. Place Sonnax Vespel[®] washer on the turbine hub pilot using assembly gel to hold it in place.
- d. Insert turbine/turbine hub assembly into piston, ensuring the turbine drops into piston as far as it can go.

5. Sprag Cartridge Installation

The Sonnax sprag cartridge comes preassembled.

- a. Remove impeller-side snap ring from OE stator (thinner blade-side). Leave turbine-side snap ring installed.
- b. Remove and discard OE clutch and stator caps.
- c. Select the small Sonnax thrust bearing provided in base kit **GM-RK-20MWC**. Place bearing on Sonnax turbine-side stator cap.



NOTE: The two stator caps appear identical but are not. The smaller thrust bearing does not fit the impeller-side cap.

- d. Insert Sonnax sprag cartridge with small thrust bearing oriented toward turbine-side of stator.
- e. Install Sonnax impeller-side stator cap and secure with OE snap ring.

6. Converter Assembly

- a. Place small Sonnax thrust bearing and stator assembly on turbine hub, thin blade-side on top. Place large Sonnax thrust bearing on the stator assembly, then place impeller and impeller hub on bearing and weld impeller to the cover.
- b. The overall height for this 4L60-E, 4L65-E, 4L75-E (300mm) race converter is 6.525".