

GM 4L80-E, 4L85-E, Multi-Plate

Unit Size: 258mm • Core: 258mm • Dampened: No • Turbine Hub Input Spline Count: 35

Performance Converter Kit

Part No.

GM-RK-488WC

- Pilot
- 35-Tooth Turbine Hub
- Rivets (20)
- Sprag Cartridge
- Impeller Hub

Patent No. 6,902,046

NOTE: Street/Strip applications only. For use with GM 258mm early-style stators only. This kit must be completed with Sonnax included multi-plate base kit and additional OE salvaged parts.

Included:

Multi-Plate Base Kit

Part No.

GM-RK-20MWC

- Front Cover
- Washer Vespel[®]
- O-Ring Fluorocarbon
- Seal PTFE
- Clutch Plate with External Splines, Woven Carbon Friction
- Clutch Plate with Internal Splines, Woven Carbon Frictions
- Damperless Piston
- Thrust Bearing Turbine-side
- Thrust Bearing Impeller-side

NOTE: The impeller and turbine MUST be furnace-brazed.

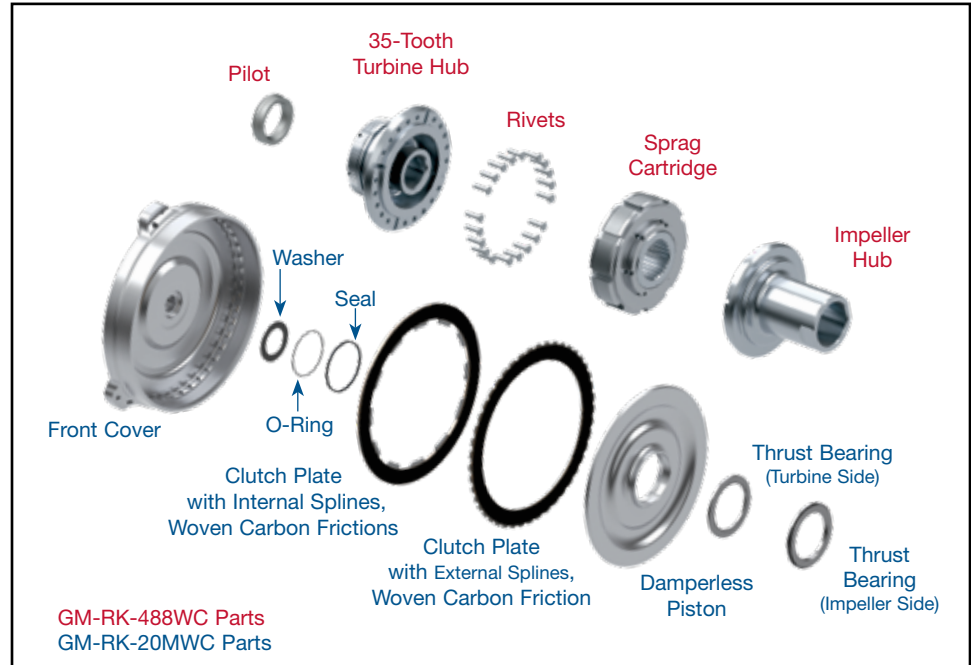

1. Front Cover Assembly

- The cover must be machined to fit the GM 258mm converter core parts (**Figure 1**).
- The pilot is a sliding-fit to light press-fit on the cover. Insert Sonnax pilot all the way to the back surface of the cover and weld in place at the pilot inside diameter.



CAUTION: Weld the pilot on the cover before assembling the rest of the converter to prevent heat damage to the Vespel washer.

2. Damperless Piston Assembly

- Install Sonnax internal spline clutch plate, followed by Sonnax external spline clutch plate. External spline plate will engage in the cover splines.
- Place Sonnax piston over clutch plates. Rotate piston until it drops and engages with internal spline clutch plate.
- Place Sonnax Vespel washer on Sonnax turbine hub, using assembly gel to hold washer in place.
- Insert turbine hub into piston and check clutch release clearance with a feeler gage. It should measure between .040-.055" (**Figure 2**).

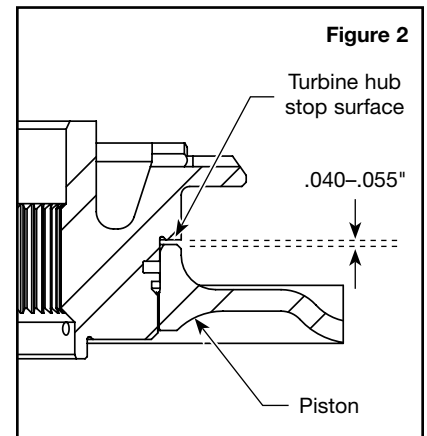
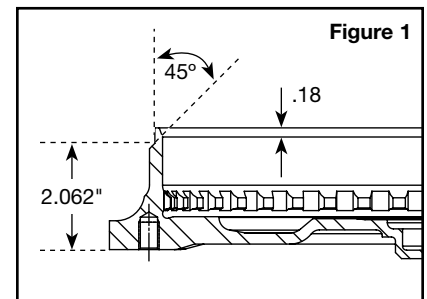

2. Damperless Piston Assembly (continued)

- e. If additional clutch release clearance is needed, the turbine hub stop surface can be machined.
- f. Remove turbine hub from the cover assembly.

3. Turbine Assembly

- a. The early-style turbine has only twelve rivet holes. If this turbine is used, twelve additional holes will be needed. Sonnax turbine hub can be used as a drill guide for the additional holes.
- b. Align four of the turbine holes with four of the turbine hub oil slots (**Figure 3**).
- c. Flip the turbine over so the turbine hub is on top. Ensure the holes and slots are still aligned.
- d. Insert four Sonnax rivets 90° apart to keep the turbine hub from rotating.
- e. Drill the missing twelve holes in the turbine using an 11/64" drill bit, for a total of 24 holes.



CAUTION: Only twenty rivets are used; the four other turbine holes and turbine hub slots are used for oil passages. Do not plug these four holes with rivets or weld bead!

- f. Rivet turbine hub to turbine.

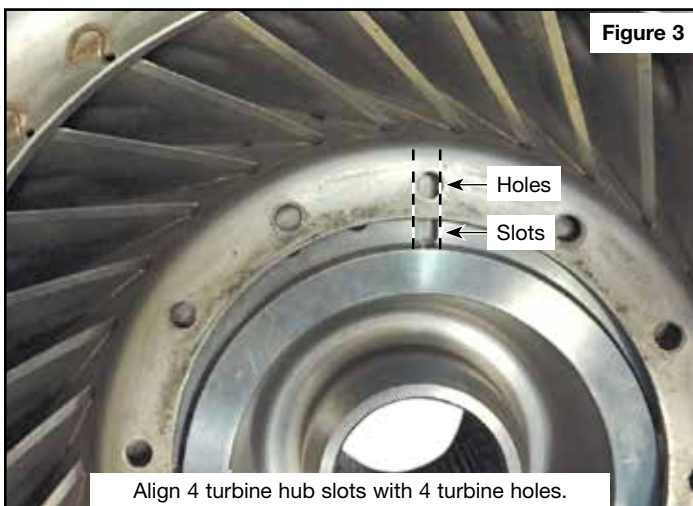

Figure 3

Align 4 turbine hub slots with 4 turbine holes.

4. Piston & Clutch Plate Assembly

- a. Install clutch plates and piston (see step 2 "Damperless Piston Assembly").
- b. Install Sonnax O-ring, then the Sonnax PTFE seal onto turbine hub.
- c. Place Sonnax Vespel washer on the turbine hub pilot using assembly gel to hold it in place.
- d. Insert turbine/turbine hub assembly into piston, ensuring the turbine drops into piston as far as it can go.

5. Sprag Cartridge Installation

The Sonnax sprag cartridge comes preassembled.

- a. Remove impeller-side snap ring from OE stator (thinner blade-side). Leave turbine-side snap ring installed.
- b. Remove and discard OE clutch and stator caps.
- c. Select the small Sonnax thrust bearing provided in base kit **GM-RK-20MWC**. Place bearing on Sonnax turbine-side stator cap.



NOTE: The two stator caps appear identical but are not. The smaller thrust bearing does not fit the impeller-side cap.

- d. Insert Sonnax sprag cartridge with small thrust bearing oriented toward turbine-side of stator.
- e. Install Sonnax impeller-side stator cap and secure with OE snap ring.

6. Converter Assembly

- a. Place small Sonnax thrust bearing and stator assembly on turbine hub, thin blade-side on top. Place large Sonnax thrust bearing on the stator assembly, then place impeller and impeller hub on bearing and weld impeller to the cover.
- b. The overall height for this 4L80-E/4L85-E race converter is 6.930".