

Smart-Tech® Overrun Clutch Valve Kit

Part No.

34200-40K

- Socket-Head Cap Screws (2) Short
- Socket-Head Cap Screw Long
- Button-Head Screws (2)
- Retaining Pins (2)
- Aluminum Plugs (2) Small, 1 Extra
- Rivets (2) 1 Extra, *Not Shown*
- Valve Manifold
- Short Tube
- Long Tube
- S-Shaped Bracket
- Flat Bracket
- L-Shaped Bracket
- Gasket
- End Plug
- Valve
- Spring
- Sleeve
- Tabbed Bore Plug
- O-Rings (3) 1 Extra
- Cup Plugs (2)
- Alignment Pins (2)
- Drill Jig
- Drill Bit Small (.109" dia.)
- Drill Bit Large (.180" dia.)

NOTE: Fits units '97-later. With minor lube tube modification, the Sonnax kit can be installed in '92-'96 units. Please contact Sonnax Product Support for more information.

NOTE: See **Figure 11** for overrun clutch apply chart before and after kit installation.

Patent No. 10,161,505

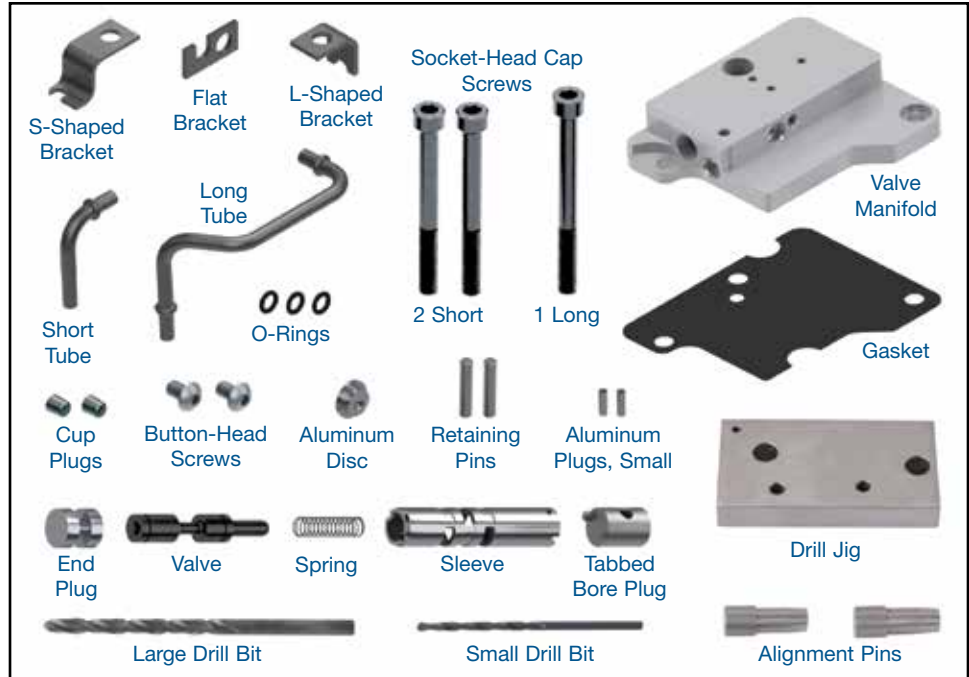
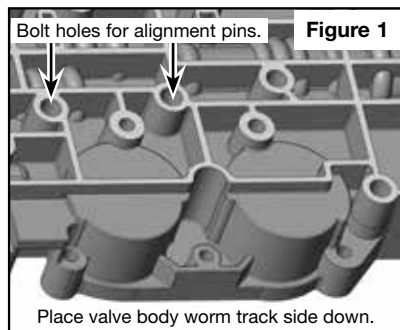

NOTE: Any other modifications to the valve body should be completed prior to installing Sonnax Smart-Tech overrun clutch valve kit.

1. Disassembly

- a. Remove valve body from transmission.
- b. Disassemble and clean thoroughly removing accumulator body and separator plate.
- c. Place the valve body worm track side down on a clean work space (**Figure 1**).

2. Valve Body Preparation

- a. Place drill jig on valve body (**Figure 2**).
- b. Insert two alignment pins through drill jig holes into casting bolt holes.
- c. Using large drill bit (.180" dia.) drill through large drill jig holes and through casting.
- d. Measure and mark provided small drill bit (.109" dia.) from the cutting tip to 1-9/32". Drill through small drill jig hole (**Figure 2**) at an angle until the 1-9/32" mark on bit is reached. Do NOT over drill into the next passage, as this will create a bind in Drive and Reverse (**Figure 3**).
- e. Proper hole locations are shown in casting after drilling (**Figure 4**).

GM 4L80-E, 4L85-E

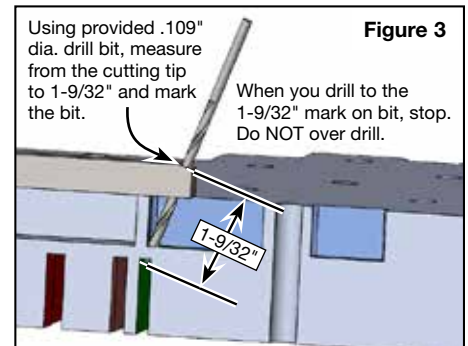
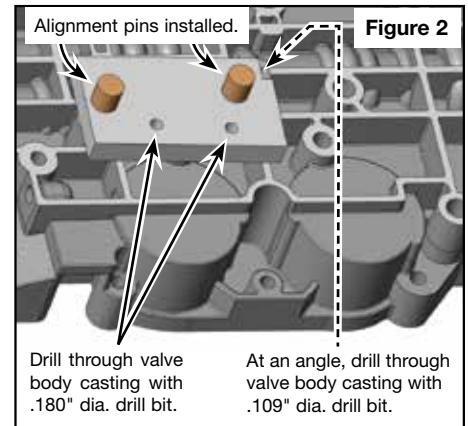

2. Valve Body Preparation (continued)

f. Clean casting to remove all chips and debris.



TUBE INSTALLATION TECH TIP: Ends of tubes are tapered to ease installation into the three hole locations (**Figure 4**), install the tapered end of the tube and twist the tube back and forth with slight downward pressure then remove until final assembly.

3. Valve Assembly & Cup Plug Install into Sonnax Valve Manifold

a. Install valve into sleeve with the long spring stem of valve toward end of sleeve with small drilled cross hole (**Figure 5**). Install spring onto stem of valve. Install valve/sleeve/spring assembly into front of valve manifold with sleeve notches in 3 and 9 o'clock positions (**Figure 6**).

b. Install Sonnax end plug into front side of valve manifold and install Sonnax retaining pin (**Figure 6**).

c. Install Sonnax tabbed bore plug into back of valve manifold with tabs at 3 and 9 o'clock positions so tabs are inserted into sleeve notches. Install Sonnax retaining pin through valve manifold and tabbed bore plug as shown (**Figure 6**).



NOTE: To aid alignment of sleeve to tabbed bore plug use a pick thru exhaust orifice in manifold (**Figure 6**).

d. Carefully press Sonnax cup plugs into valve manifold side holes as indicated (**Figure 6**). Open face of cup plugs should be just past flush with side of valve manifold. Lightly stake edge of bore to lock cup plugs into manifold.

4. Tube Installation & Assembly

a. Install Sonnax O-ring onto Sonnax short tube (**Figure 7**). Lubricate O-ring and manifold bore. Install tube with O-ring into manifold being careful not to damage O-ring.

b. Secure Sonnax short tube to valve manifold with L-shaped bracket and button-head screw. Torque to 40 in-lb.

c. Install Sonnax O-ring onto Sonnax long tube (**Figure 7**). Lubricate manifold bore and O-ring. Install tube with O-ring into manifold being careful not to damage O-ring.

d. Secure Sonnax long tube to valve manifold with Sonnax flat bracket and button-head screw. Torque to 40 in-lb.

e. Place Sonnax gasket on bottom of valve manifold using TransJel (**Figure 8**).

f. Install valve manifold with tubes and gasket on top of valve body (**Figure 9**). The ends of tubes are tapered, and need to enter previously drilled holes in casting (**Figure 4**). It may be necessary to gently tap the long tube into the drilled holes until the bottom bead on long tube and manifold are flush with casting. Tube seals on the taper, not the bead. If the bead doesn't go all the way flush but taper is sealing this is sufficient.

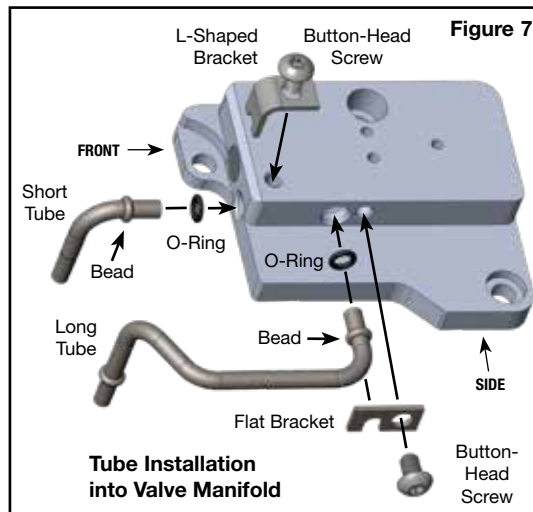
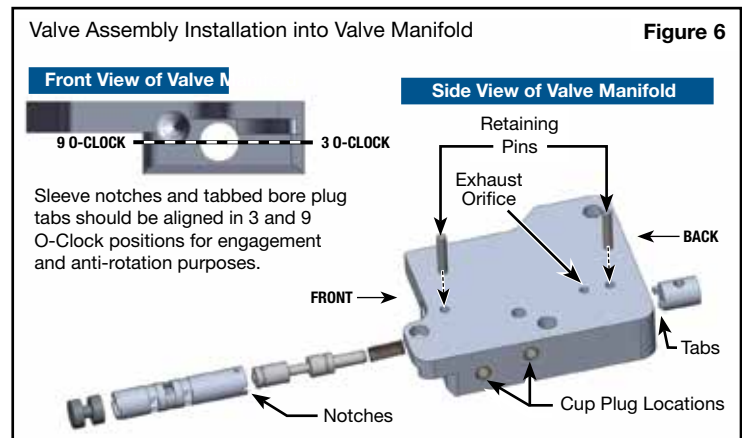
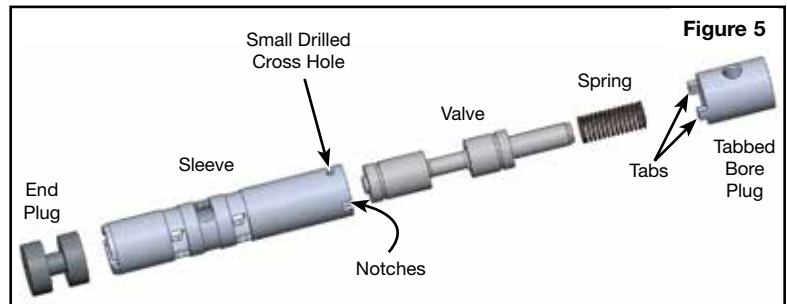
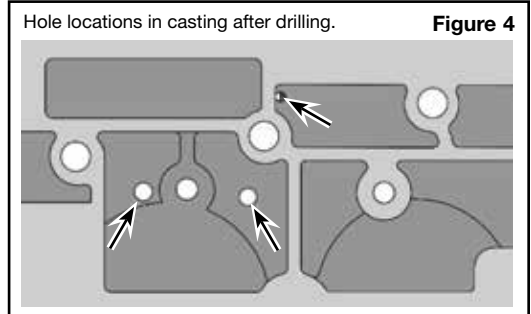

5. Separator Plate Modifications

- If using Sonnax aluminum plug (.062"), install into indicated separator plate orifice (**Figure 10**). It may be necessary to slightly enlarge plate orifice first. Mushroom plug on both ends by hitting with hammer while plate is on a hard surface.
- If using optional small rivet, insert into orifice and using wire cutters, snip the stem end of the rivet if/as necessary to provide for a small head once peened in place. Peen the rivet in place on head side of plate also.
- After peening on both sides of the plate, ensure plate will still fit flush on mating surfaces.
- Place aluminum disc plug through indicated separator plate hole (**Figure 10**). Place end of a center punch in middle of plug and hit with hammer to expand plug to seal plate hole.
- Discard OE check ball #1 (overrun checkball) at this location.

6. Final Assembly

- Reassemble modified valve body separator plate and accumulator body to valve body, and install on transmission case per OE specifications.
- Install three Sonnax socket-head cap screws into valve manifold, (**Figure 11**). Torque all to 90 in-lb.
- Install S-shaped clamp bracket OE bolt (**Figure 12**) and torque to 90 in-lb.

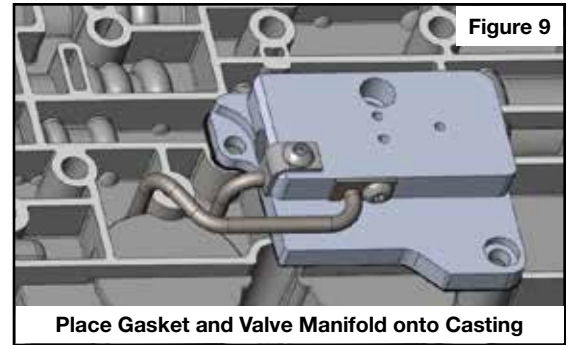
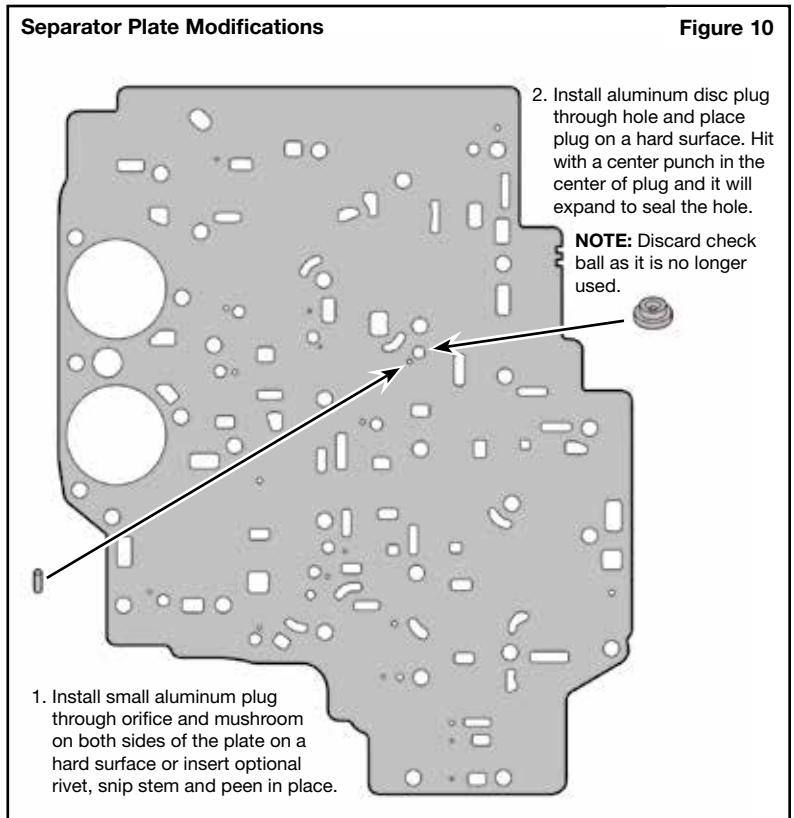

Figure 9

Place Gasket and Valve Manifold onto Casting



Separator Plate Modifications

Figure 10

4L80 Apply Chart

Figure 12

Range	Gear	Overrun Clutch with Sonnax 34200-40K Clutch Valve Kit	Overrun Clutch with OE Clutch Valve
Park		Applied	
Reverse		Applied	
Neutral		Applied	
Over-Drive	1st	Applied	
	2nd	Applied	
	3rd	Applied	
	4th		
Drive	1st	Applied	Applied
	2nd	Applied	Applied
	3rd	Applied	Applied
D2	1st	Applied	Applied
	2nd	Applied	Applied
D1	1st	Applied	Applied

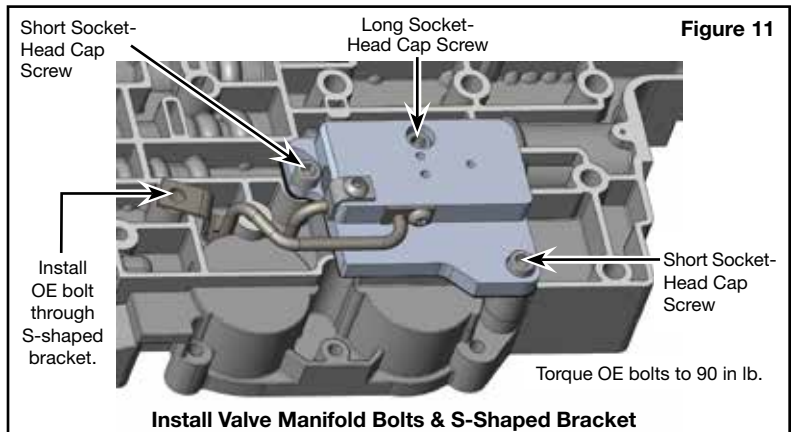

Figure 11

Install Valve Manifold Bolts & S-Shaped Bracket