

Bolt & Washer Kit

Part No.

MB-FN-2K

- Bolts (8)
- Washers (8)

Mercedes 722.9 (Late)

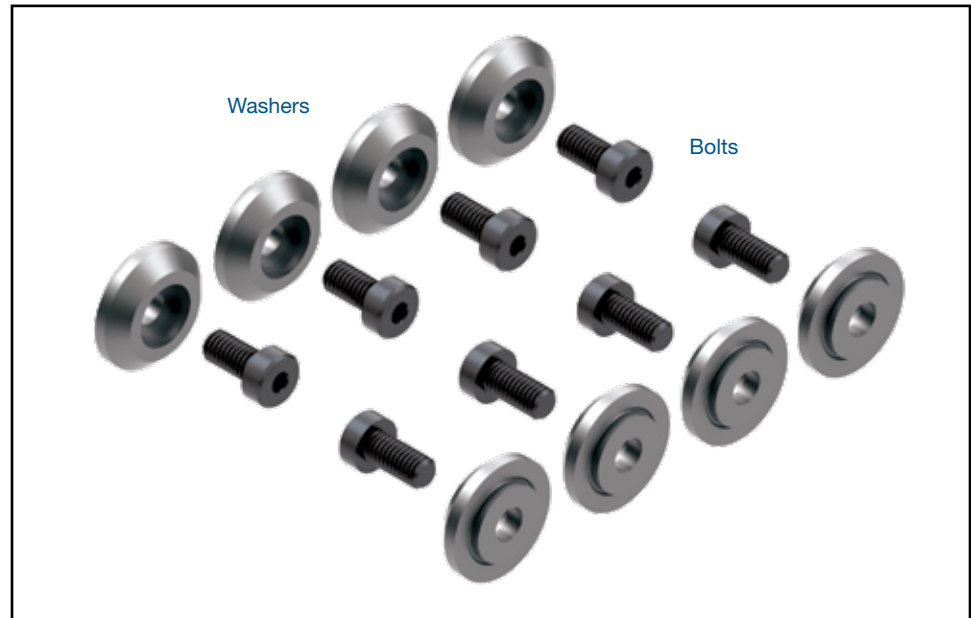

1. Disassembly

- Separate converter halves.
- Clamp front cover to machine table (**Figure 1**).
- Carefully machine eight indicated OE rivets flush, using caution to remove as little material as possible from the piston plate (**Figure 1**).
- Remove piston plate, frictions, steels, seals and wave springs.
- Machine eight rivet studs an additional .070-.080" (**Figure 2**).

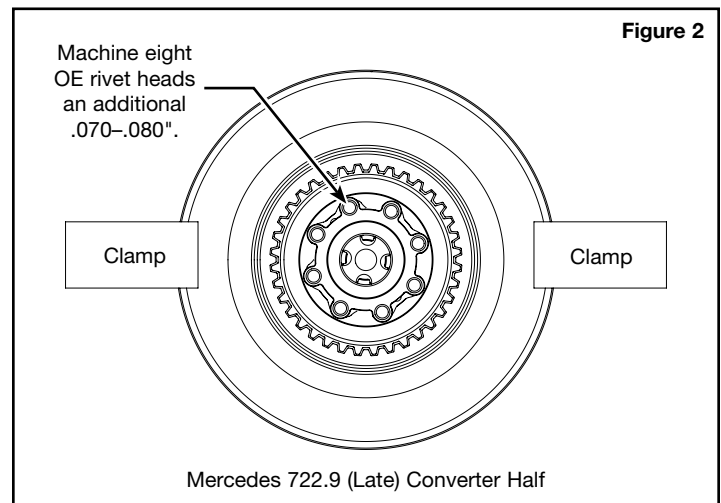
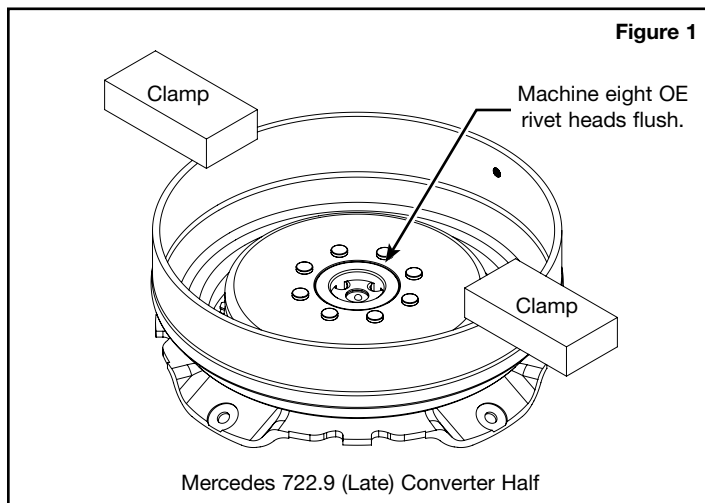

1. Disassembly (continued)

- f. Using piston plate and one washer as a template, drill one stud with 4.2mm drill x .422" depth. (Figure 3).
- g. Remove piston plate and washer. Tap one stud using M5 x 0.8 bottoming tap, thread depth .375".
- h. Install piston plate, one washer and one bolt. Use remaining seven washers and piston plate as drill template. Drill seven remaining studs, 4.2mm drill x .422" depth (Figure 4).
- i. Remove bolt, washers and piston plate. Tap remaining seven studs using M5 x 0.8mm bottoming tap, thread depth .375" (Figure 5).

2. Installation & Assembly

- a. Install steels, frictions, wave springs, seals and piston plate.
- b. Install Sonnax washers and bolts. Apply Loctite® to bolt threads and torque to 6 NM (Figure 6).

